

FIBER OPTIC SYSTEM DESIGN

Introduction to System Operation

This guide is intended to help a fiber optic system engineer become familiar with the parameters involved in designing a complete link. It is not intended to answer all design questions, but rather to present alternatives available.

While complete ready-made systems are commercially available, this guide will help the interested engineer develop a system customized to his specific needs.

The first half of this guide is a simple introduction to system operation, component selection, and Local Area, Wide Area Networks (LAN/WAN). The second half is a detailed procedure for system design.

The Advantages of Fibers:

Fiber optics communication offers several advantages over metallic (wire) or wireless systems.

Any form of outside electronic, magnetic, or radio frequency interference does not distort the transmitted signals. Therefore, optical systems are completely immune to lightning or high voltage interference.

Furthermore, optical fibers will emit no radiation, which ideally suits them for today's tougher standards in computer applications. Because optical signals do not require grounding connections, the transmitter and receiver are electrically isolated and free from ground loop problems.

With no chance of terminal-to-terminal ground potential shifts, plus safety from sparking and shock, fiber optics is increasingly the choice for many processing applications where safe operation in hazardous or flammable environments is a requirement.

Digital computing, telephone, and video broadcast systems require new avenues for improved transmission. The high signal bandwidth of optical fibers means increased channel capability. Also, longer cable runs require fewer repeaters, because fiber optic cables have extremely low attenuation rates. This ideally suits them for broadcast and long distance telecommunications use.

Compared to conventional coaxial cables with the same signal carrying ability, the smaller diameter and lighter weight of fiber optic cables means relatively easier installation, especially in crowded duct areas. A single conductor fiber optic cable weights about 9 lbs. per 1000 ft. A comparable coaxial cable weights 80 lbs. per 1000 ft. – about nine times more. Weight-conscious designers can save precious pounds using fiber optics, and increase capability.

<p><u>All Dielectric</u></p> <ul style="list-style-type: none"> ▪ Low Signal Radiation ▪ Secure Transmission ▪ RFI and EMI Immunity ▪ High Voltage Installations
<p><u>Small Size</u></p> <ul style="list-style-type: none"> ▪ Less Duct Space ▪ Fewer Additional Ducts Installed
<p><u>Low Attenuation</u></p> <ul style="list-style-type: none"> ▪ Greater Distance/Fewer Repeaters ▪ Less Installation and Maintenance
<p><u>Optical Signals</u></p> <ul style="list-style-type: none"> ▪ No Ground Loops ▪ No Spark Hazard ▪ Operation in Flammable Area
<p><u>High Bandwidth</u></p> <ul style="list-style-type: none"> ▪ Future Signal Capability Expansion

Table 1. Features of Fiber Optic Systems

Electronic “bugging” depends on electromagnetic monitoring. Fiber optic systems are immune to this technique. They have to be physically tapped to extract data, which decreases signal levels and increases error rates – both of which are readily detected. Table 1 summarized the many features of fiber optic systems.

The Fiber Optic Link:

The simple schematic diagram shown in Figure 1 consists of an optical transmitter and receiver connected by a length of optical cable in a point-to-point link.

The optical transmitter converts electronic signal voltage into optical power, which is launched into the fiber by a light emitting diode (LED), laser diode (LD) or laser.

At the photodetector point, either a positive-intrinsic-negative (PIN) or avalanche photodiode (APD) capture the lightwave pulses for conversion back to electrical current.

It is the system designer's job to determine the most cost and signal efficient means to convey this optical power, knowing the trade-offs and limits of various components. He must also design the physical layout of the system.

The first of these concerns, signal quality, involves such factor as signal-to-noise ratio (SNR) in analog systems, and bit-error-rate (BER) in digital systems. When designing a system “from scratch” the designer must determine the required SNR or acceptable BER necessary to transfer the data. The next step is to determine the minimum optical power necessary at the receiver end. This can be obtained from component manufacture's published data.

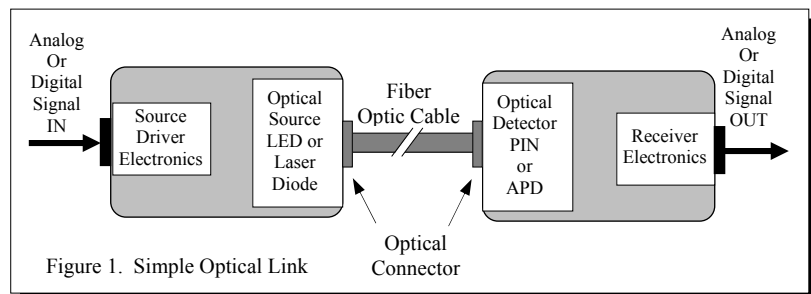

Figure 1. Simple Optical Link

Note: System Design Guide is reprinted with permission from Belden Corp.

Introduction to System Operation (Continued)

Losses and Limitations:

Link design consists basically of two functions: (1) the measuring of optical power losses occurring between the light source and the photodetector, and (2) determining bandwidth limitations on data carrying abilities imposed by the transmitter, fiber, and receiver.

Reductions in optical power loss, or attenuation, as the light pulse travels through the fiber are expressed in dB/Km (decibels per kilometer)

The decibel is a logarithmic expression of the ratio of the power entering a component and the power leaving it.

$$\text{dB} = 10 \log_{10} (\text{Power Out}/\text{Power In})$$

A 3dB loss means that half the power is lost. For example, starting with 500µw, you would now have 250µw. A 10 dB loss means that 10% of the power arrives at the receiver, a 90% loss.

Fiber optic links can operate with as little as 0.1% of the input power being received by the stated minimum requirements of the receiver selected.

Transmission Power Loss:

The prime causes of optical attenuation in fiber systems are:

- Coupling loss
- Optical fiber loss
- Connector loss
- Splice loss

The sum of all the losses of each individual component between transmitter and receiver comprise the Optical Link Power Budget shown in Figure 2.

The designer must consider these losses and select a transmitter and receiver combination that will deliver enough power to faithfully reproduce the signal.

However, these losses are not exact, and manufacturers typically state ranges, or "best" and "worst" case situations in order to account for product variations. Also some allowance may be required for such things as temperature variations.

Some safety margins should also be made for future repairs or splices to the system, and age degradation of the source emitter. For example, a 3dB margin for repairs and aging of the emitter is commonly employed.

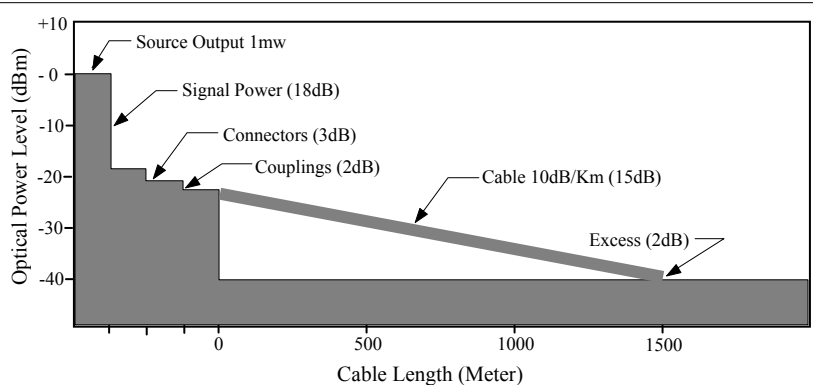

	Actual Power	Optical Power Level
Minimum optical power required by the receiver	0.1 µW	-40 dBm
Source output optical power	1 mW	0 dBm
Total operating budget (optical power)		
		40 dB
SNR voltage ratio required in the receiver is 36dB. The equivalent optical power is *		
		18 dB
Remaining optical power for link		
		22 dB
Link optical power losses:		
Cable	15 dB	
Connectors	3 dB	
Couplings	2 dB	
Total	20 dB	
		Excess budget 2 dB

*The optical power is related to the signal voltage ratio by a factor of two because $\text{dB} = 10 \log P_1/P_2 = 10 \log I_1^2 R_1^2 / I_2^2 R_2^2$. Since $V = IR$ then $\text{dB} = 20 \log V_1/V_2$.

Figure 2. Typical Optical Link Power Budget

Coupling Loss:

The amount of optical power coupled into the fiber is dependent on the physical nature of the fiber used, and the source emitter.

Obviously, the larger the core diameter of the fiber, the more potential for accepting light. However, larger core fibers suffer bandwidth limitations that may outweigh coupling efficiency.

A change in core diameter from 50µm to 100µm (microns) represents an increase of four times in the amount of light coupled to the fiber.

Besides core size, the other measure of a fiber's ability to collect optical power is called numerical aperture (NA). This is a mathematical measure of the fiber core's ability to accept lightwaves from various angles and transmit them down the core.

A large difference between the refractive indices of the core and cladding means a larger NA.

For equal core size, a fiber with a larger NA will accept more lightwaves. A power increase by about a factor of two is achieved by going from an NA of 0.20 to one of 0.29.

We've combined the effects of core size and NA into an Optical Collection Factor, which can be considered a measure of the fiber's efficiency for optical radiation (see Table 2).

Fiber Core Dia. Microns	Numerical Aperture	Collection Factor	
		Relative*	dB Ratio
300	0.27	14.1	+11.5
200	0.27	6.2	+8.0
200	0.18	1.6	+2.2
100	0.28	1.0	+0.0
85	0.26	0.62	-2.1
62	0.29	0.4	-3.8
50	0.20	0.13	-8.9

*Values normalized to short length of 100 micron core fiber.

Table 2. Optical Collection Factor

Component Selection

Source Emitters:

Optical emitters couple light into a fiber according to NA and core size. Using a light source not matched to a particular fiber's NA and core size will cause less than optimum light coupling for the system.

LED's are relatively inexpensive, reliable and easy-to-use because their electronic circuitry is less complex than that required for a laser. Typical laser and LED characteristics are shown in Table 3.

	Laser	LED
Light Output	6 dBm	0.6 dBm
Coupling Loss	3 dB	20 dB
Spectral Width at 800 nm at 1300 nm	2 nm 4 nm	40 nm 100 nm
Temperature Sensitivity	Strong	Weak
Feedback Control	Yes	No
Failure Mechanisms	Many	Few
Cost (Relative)	100	1

Table 3. Comparison of Typical Parameters of Lasers and LEDs

Semiconductor lasers and LEDs are both direct transducers from electrical to optical radiation. LEDs couple less power into the fiber because they emit the optical radiation over a broader angle area. The laser is a much more complicated structure due to the requirement for a small dual-face cavity. Also its output is temperature dependent and the lifetime is less than the LED.

Several different LED packaging styles are commercially available, as seen in Figure 3.

The LED or laser diode can be packaged so that the fiber cable plugs directly into the device package. An alternative is fastening the fiber directly to the chip and leaving the opposite end available for a connector.

Matched transmitter and receiver units, plus a wide variety of other optic components ranging from discrete elements like LEDs, laser diodes, and detectors to complete rack-mounted modules are all readily available.

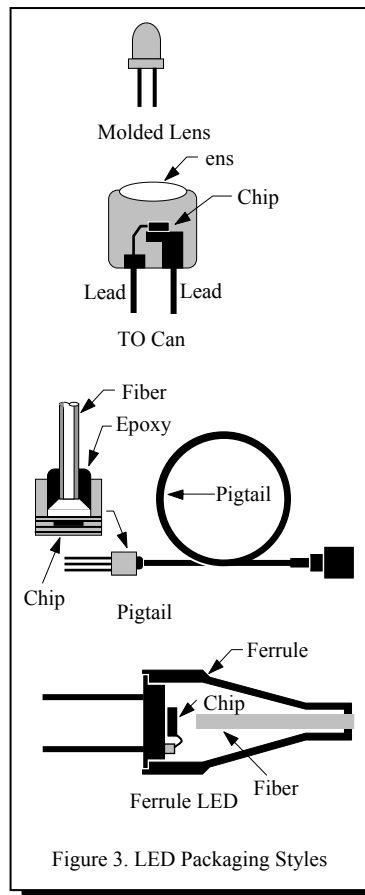

Figure 3. LED Packaging Styles

Detectors:

Lightwave receivers use photodetectors, where the photons of light generate photoelectrons. A minimum average number of photons in each pulse is necessary to achieve a given-error probability (21 photons for 10^{-9} error probability). Considerable amplification is necessary. For an avalanche-photodiode (APD) initial amplification is internal. For positive-intrinsic-negative detectors (PIN) this amplification is by external electronic amplifiers.

Optical Fiber Loss:

We've already considered core size and numerical aperture as measures of fiber's ability to accept the optical power. Now let's consider what happens to the optical signal once it's launched.

In coaxial cable, high frequency signal strength decreases with distance and this is referred to as attenuation. Fiber does not have the same frequency dependent attenuation. Fiber frequency is constant until it reaches its bandwidth limit. Thus optical loss is proportional to distance.

This attenuation within the fiber is caused by absorption and scattering of lightwaves due to chemical impurities and molecular structure. These fiber properties absorb or scatter the optical radiation so that it escapes the core and is lost.

Attenuation within a fiber is specified by the manufacturer at certain wavelengths: for example 5dB/Km at 820 nanometers. This is done because fiber loss varies with wavelength, as seen in Figure 4.

These wavelength are measured in nanometers (nm) – billionths of a meter – which represent the distance between two cycles of the same wave. Wavelength is a descriptive property of electromagnetic radiation. Light and infrared radiation are portion of the total electromagnetic spectrum.

Microwaves, radar, television and radio operate in the longest wavelength areas. In between the ultraviolet and the microwave spectrums, we have fiber optic wavelengths, which are in the infrared spectrum.

Fiber Selection:

Fibers are therefore optimized for operation at certain wavelengths. For example, less than 1dB/Km loss is attainable in $50/125 \mu\text{m}$ multimode fiber operating at 1300 nm, and less than 3dB/Km (50% loss) is attainable for the same fiber operating at 850 nm. The $50/125$ nomenclature indicates both the outside diameter of the core (50 microns) and the cladding (125 microns).

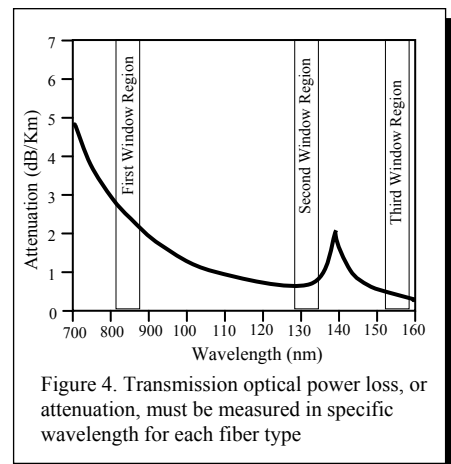

Figure 4. Transmission optical power loss, or attenuation, must be measured in specific wavelength for each fiber type

Component Selection (Continued)

The favorable transmission regions within the optical spectrum for a fiber are referred to as "windows". The 800 to 900 nanometers region is the first window, 1100 to 1300 nanometers is the second window, and the third window occurs at about 1500 nanometers. In these spectral windows fibers have very low attenuation. The lowest losses occur in the infrared region around 1300 nm and again around 1500 nm.

Great improvements have been made in all fiber types so that premium fibers exhibit losses of less than 0.5dB/Km at wavelengths of 1300 and 1500 nm. However, source emitters and detectors for these regions are currently more expensive.

If the fiber is to perform well, the source chosen should provide optical radiation at the specified wavelength, and the detector should be sensitive to the same wavelength.

In coaxial and other metallic cables, very high frequency signals tend to be attenuated rapidly with distance. As a result, amplifiers and equalizers are required at periodic intervals to build up signals to usable levels.

However, each time an analog amplifier is added, noise is introduced to the metallic system, and the overall system signal-to-noise ratio degrades.

With optical communications, all of the light energy is at approximately the same frequency or wavelength. As a result, the attenuation of a specific wavelength is dependent only on distance. See Figure 5 for a comparison of attenuation differences between coaxial and fiber optic cable. The requirement for repeaters is, therefore, minimized and the need for equalizers is eliminated in fiber system.

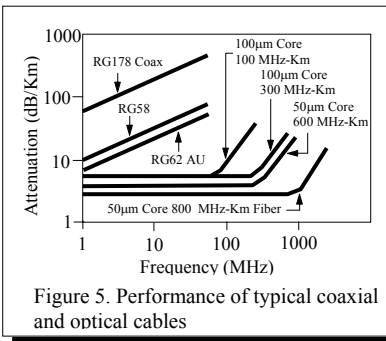

Figure 5. Performance of typical coaxial and optical cables

Connector Loss:

Connector loss is a function of the physical alignment of one fiber core to another fiber core.

Scratches and dirt can also contaminate connector surfaces and severely reduce system performance, but most often the connector loss is due to misalignment or end separation.

Several styles of fiber optic connectors are available from major connector suppliers.

Typically, each has its own design and is generally not compatible with any other manufacturer's connectors. However, an SMA, ST, SC, or LC type connectors do offer mechanical compatibility.

Depending on connector type, different terminating techniques are used:

- Epoxy and polish: The fiber is epoxied in place in an alignment sleeve, then polished at the ferrule face.
- Optical and mechanical: Both lenses and rigid alignment tubes are commonly used. In addition, index matching mediums may be employed.

The optical power loss of a connector-to-connector interface typically runs between 0.25 and 1dB, depending on the style of the connector and the quality of the preparation.

Splice Loss:

Two fibers may be joined in a permanent fashion by fusion, welding, chemical bonding, or mechanical joining. A splice loss that is introduced to the system may vary from as little as 0.15dB to 0.5dB.

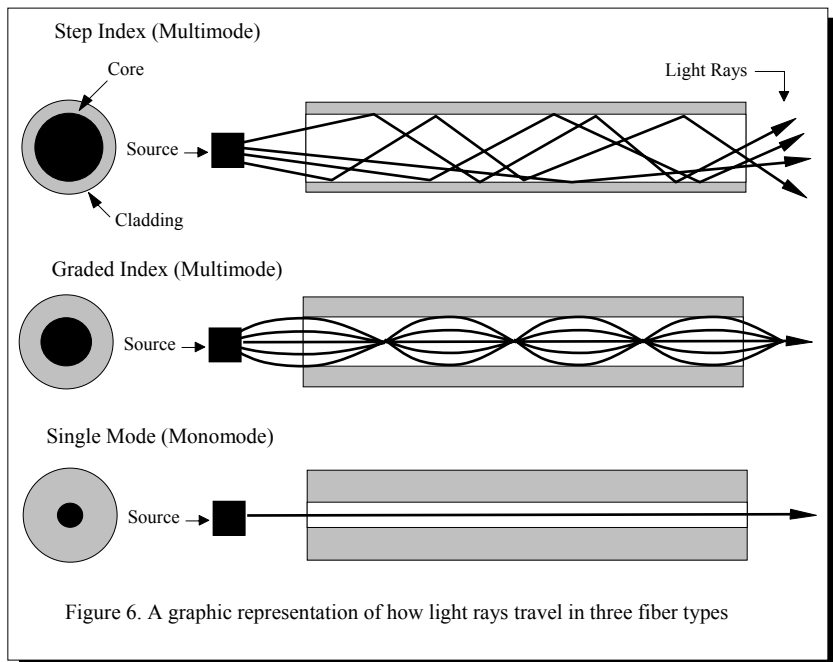

Figure 6. A graphic representation of how light rays travel in three fiber types

Bandwidth

Up to this point, we've covered loss of optical signal power both within the fiber and within the system.

Now let's examine the other major determinant of fiber optic signal performance: bandwidth.

Because of their large comparative bandwidths, fibers can carry large amounts of information. A single graded index fiber can easily carry 500 million bits/second (Mb/s) of information. However, bandwidth capacity limits exist for all types of fibers and depend on the fiber and type of emitter employed.

The three fiber types shown in Figure 6 can be identified by the type of paths that the rays of each light pulse travel within their fiber cores.

To accurately reproduce data, light pulses must be kept separate and distinct with correct shape and spacing during transmission. Yet, the rays comprising each pulse travel in many different paths within a multimode fiber. For step index fibers, for example, modes traveling at different angles as they zigzag down the fiber arrive at the receiver end at different times.

This arrival time variance results in distorted and overlapping pulses at the receiver end as seen in Figure 7. This "modal dispersion", or spreading of the light pulse limits the frequency that can be transmitted, because the detector cannot tell where one pulse ends and the next begins.

The time difference between the fastest and slowest mode of light entering the fiber at the same time and traveling a kilometer may only be 1 to 3 nanoseconds, yet this modal dispersion causes major limitations on the system's operating speeds over long distance. Doubling the distance, doubles the dispersion effect.

Just as optical power loss reduces signal performance, a system can be bandwidth limited when the shape of the light pulse is distorted beyond specified limits.

Modal dispersion is often expressed in nanoseconds per kilometer, e.g. 30ns/km. The same effect may also be expressed as a frequency, such as 200 MHz-km. This indicates that the fiber or system will operate efficiently up to 200 MHz before dispersion adversely affects signal performance over a one kilometer length. The same system could transmit a 100 MHz signal as far as two kilometers.

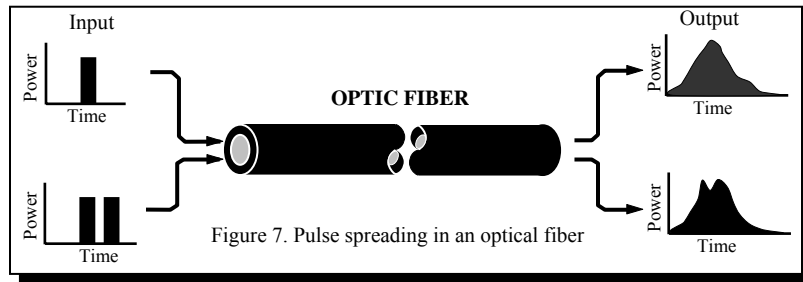

Figure 7. Pulse spreading in an optical fiber

Dispersion makes the multimode step index fiber the least bandwidth efficient of the three types. It is therefore used for shorter runs and lower operating frequencies, e.g. 20 MHz-km.

Single mode fiber has small core sizes of 8 to 10 μm diameter in order to allow only one lightwave ray to propagate down the fiber. Because modal dispersion is completely eliminated, this fiber has much greater bandwidths which can exceed several hundred gigahertz per kilometer (GHz-km).

However, fibers are susceptible to another type of dispersion problem caused by the fact that different wavelengths traveling at different velocities through a medium.

This "spectral dispersion" is evident when white light decomposes into a rainbow of colors by a glass prism. Each wavelength travels at a different speed leading to unequal amounts of bending of the rays associated with each color.

If the fiber system's spectral source emitted a single frequency of light, this spectral dispersion, or material dispersion (or chromatic dispersion, as it is also often called) would be eliminated. However, an LED light source has a spectral range of about 20 times that of a laser, and thus has much greater spectral dispersion. Dispersion in glass fiber disappears around 1.3 μm , allowing mono mode fibers extremely large bandwidth capacities at this wavelength.

Mono mode fibers is typically used with laser emitters, because of their greater spectral purity. Precision connectors and splicing are required.

Because of their low loss, and high capacity qualities, mono mode fibers are the choice for constructing long, high data rate links, such as cross-country telecommunications.

Between mono mode and step index fibers, there are graded index fibers. Rays in a graded index fiber are gradually redirected back toward the core's axis during propagation to reduce the effects of modal dispersion. Graded index fibers have much greater bandwidth capacities than step index fibers. A 600 MHz-km graded index fiber can transmit a 20 MHz modulation signal as far as 30 km. The cost of this glass fiber is currently one of the lowest. Its low loss plus high bandwidth make it the fiber of choice for most local area network applications, for example.

LCF (Laser Certified or Laser Enhanced Fiber):

The new fiber features LCF to handle the new light sources required in short wavelength gigabit Ethernet systems. The new light sources, named VCSEL (Vertical Cavity Surface Emitting Lasers) are designed to operate at the short wavelength of 850nm, the same wavelength as today's LED light sources. LCF 62.5 and 50 micron multimode fiber ensures compliance with new laser technology. The LCF fiber utilizes enhanced bandwidth and tight attenuation limits to meet and exceed the EIA/TIA-TSB72 300 meter backbone length.

LCF fiber has been deployed across the entire cable series. It is operational with current LED light sources and exceeds FDDI+ performance specifications. LCF will be also be able to handle low-cost, long-wavelength VCSEL light sources currently being developed.

LCF Lengths for Gigabit Ethernet			
Core Size	Wavelength	SX	LX
62.5	850nm	300m	N/A
	1300nm	600m	600m
50	850nm	300m	N/A
	1300nm	3600m	600m

Local Area Networks (LAN)

Bandwidth Summary:

To this point we've covered how pulse spreading or dispersion limits the maximum bandwidth that may be used with fibers. The different propagation pathways cause delays, or modal dispersion in multimode fibers.

Modal dispersion is the principal bandwidth limitation for laser-based multimode fiber systems at 850 nanometers, and for both laser and LED systems at 1300 nanometers.

Spectral dispersion provides the principal bandwidth limitation for LED based systems at the first window of 850 nanometers of about 100 MHz-km, and for single mode laser-based systems (typically more than 50 GHz-km) at the 1300 nanometer region.

The basic loss mechanism, or attenuation, within fibers is caused by light scattering which varies by wavelength. The 1300 nanometer wavelength is important because not only is attenuation low at this point, but spectral dispersion is generally a minimum at this wavelength.

Fibers have a constant loss over a wide range of modulation rates, but there is a rapid increase in effective loss when pulse dispersion becomes compatible to the pulse period. Contrast this with base band metallic systems where attenuation increases as the square root of the modulation rate. Provided dispersion is small, fiber systems do not require equalization and line amplifiers which are necessary with metallic systems.

Local Area Networks (LAN):

The explosive growth of personal computing in the business marketplace and the increasing sophistication of multiple-function local area networks are forcing system developers into an examination of not only what operating systems to use, but also what would be the optimum cable/system design.

The growing requirements for bandwidth in computer applications, and the need to adapt to other inter-and intra-building telecommunications needs such as telephone, security, alarm and video have all dramatically increased the demand for optical fiber.

Fiber optic LANs generally have a maximum link distance between transmitter/receiver pairs of 2 km. They may be isolated to only one floor or one building, or be interconnected with other networks among several buildings.

A system can be low-speed, low-capacity such as telephone, or high-speed, high-capacity such as video. Although copper and fiber can both be used or intermixed in a LAN system, the high information capacity and upgradeability of fiber is increasingly making it the choice. Instead of rewiring to add future capacity, changing the electronic hardware at the system ends is all that's necessary to alter these systems. Many designers add extra fibers to a system for this purpose.

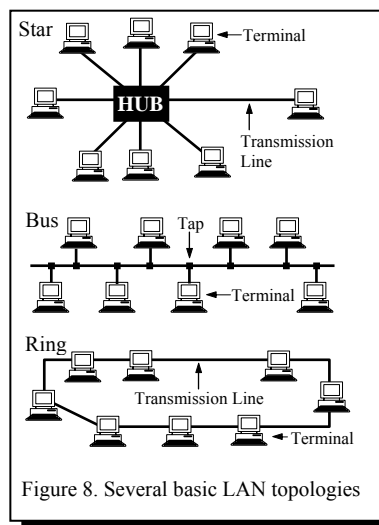

Figure 8. Several basic LAN topologies

Figure 8 shows several examples of the basic LAN topologies: star, ring, and bus.

Star LANs are arranged around a single hub that may act as a central controller for network. Transmission sent from one node or terminal must first pass through the hub. This hub can simply be a passive star coupler or an active controller or a switch.

In a ring type network, all terminals are linked in a point-to-point series. If one part fails, the system is down unless bypass components are used. To avoid conflicting data demands such systems use a bit pattern, called a token. The token is circulated to each node allowing that node to capture the token and the right to transmit data. IBM has a ring network shown in Figure 9. Other systems and software are also on the market.

Networks based on a bus topology also use a token passing scheme, or an access scheme known as carrier-sense multiple access with collision detection (CSMA/CD), or collision

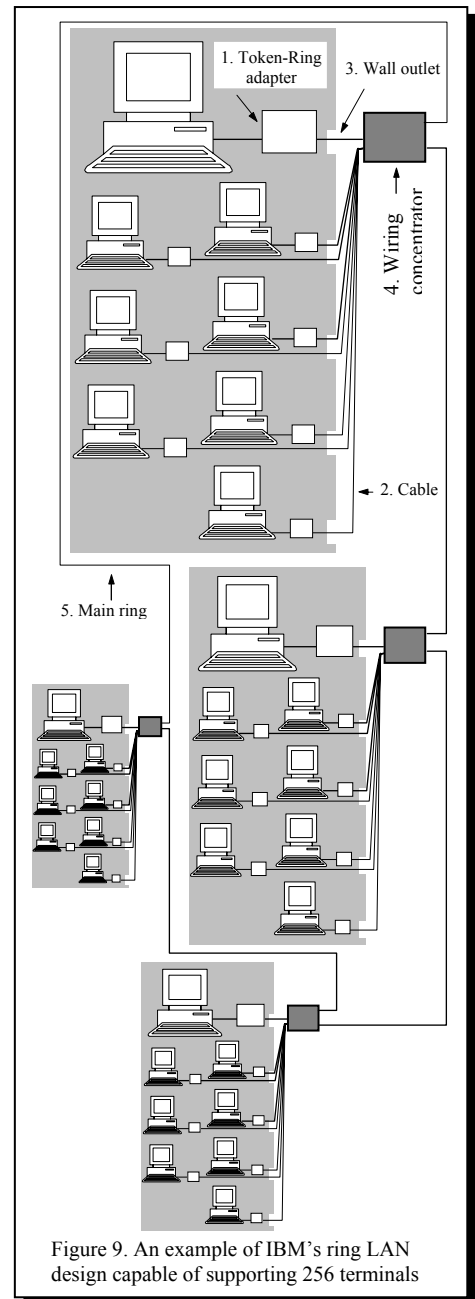

Figure 9. An example of IBM's ring LAN design capable of supporting 256 terminals

avoidance (CSMA/CA). Like a ring, messages on the bus are broadcast to all terminals. Since all the terminals tap into a single main trunk channel like branches on a tree, messages do not have to be repeated.

Most LANs use combinations of bus and star networks today because of speed, easy installation or retrofit, and the fact that each node can be passive so that if one fails the network keeps functioning.

Local Area Networks (Continued)

Interconnecting Components:

LAN networks can be easily configured because the fiber optic cable can be easily strung in a plenum on a single floor, up a raceway between floors, or among several buildings.

Figures 10 and 11 show typical examples of LAN layouts for multi-premise and single locations. There are fiber optic component pieces corresponding to every piece of electronic hardware used with any other LAN type. These devices appear in a system wherever a user connects, or where several lines join together at a node. These devices can be active, such as the transmitters and receivers that have already been discussed, or passive such as taps, distributors, couplers, concentrators, switches, relays, multiplexers, concentrators, switches, relays, multiplexers, and cross connection cabinets. They are available from a variety of vendors as discrete components, in rack-mounted modules, or as fully integrated system.

Optical taps or "Ts", and optical mixers or "star" couplers are shown in Figures 12 and 13. Both are examples of concentrators which actively or passively combine signals at nodes or user connection points in a LAN system.

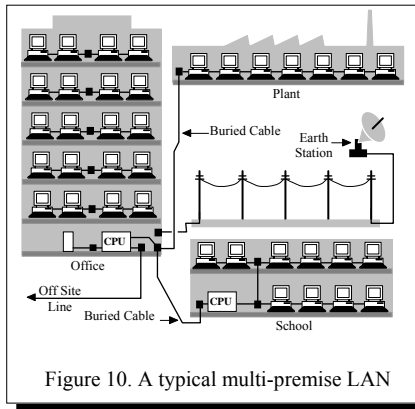

Figure 10. A typical multi-premise LAN

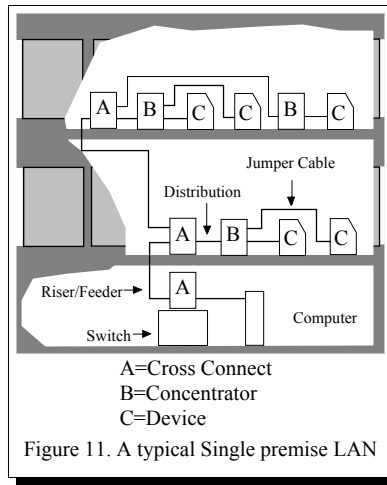

Figure 11. A typical Single premise LAN

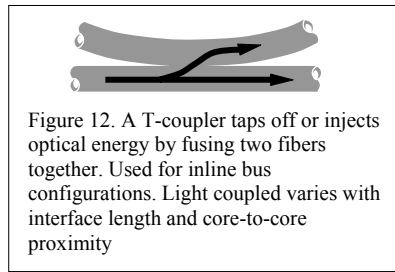

Figure 12. A T-coupler taps off or injects optical energy by fusing two fibers together. Used for inline bus configurations. Light coupled varies with interface length and core-to-core proximity

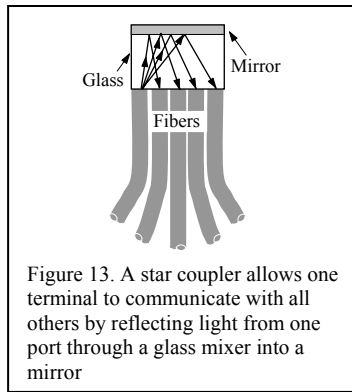

Figure 13. A star coupler allows one terminal to communicate with all others by reflecting light from one port through a glass mixer into a mirror

Simple LAN systems use "Ts", stars and other passive components between transmitter/receiver pairs. More complex systems require active components to combine, route and sometimes re-amplify the signal. Data transmission trends as outlined in Figure 14 are moving toward more active nodes as the need for greater fiber optic system flexibility, data speed, and link length increases.

As previously discussed, optical power losses occur whenever a fiber is terminated or coupled. Therefore, allowance for tapped bus or other LAN configuration requires that connectors must be factored into the system's loss budget analysis. Since many connectors are used in typical LAN networks, each must have a known loss factor.

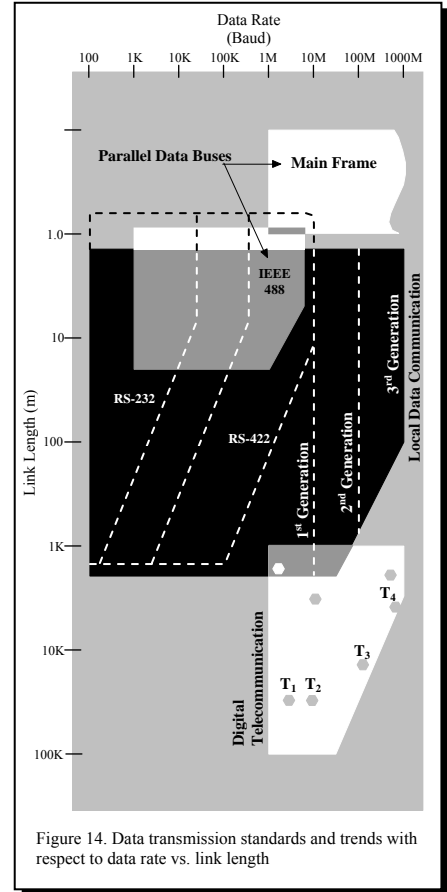

Figure 14. Data transmission standards and trends with respect to data rate vs. link length

System Design Procedure

System Analysis:

The system designer must proceed through the following five steps in order to develop a fiber optic communication system:

1. Specify the system's operational requirements.
2. Describe the physical and environmental requirements.
3. Compute the signal optical power budget.
4. Perform a signal bandwidth analysis.
5. Review the system design.

Important considerations in these steps of the design process are detailed in Figure 15. Worksheets for compiling all the data necessary to complete the design are included in the back of this brochure.

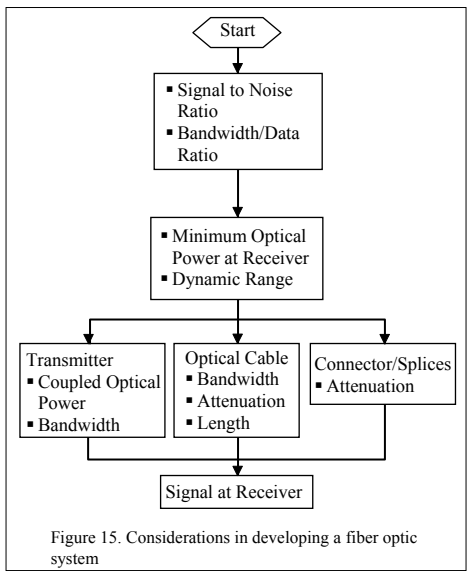

System Operational Requirements: (Step 1)

The system design process begins with a determination of the signal-to-noise ratio which depends on the bandwidth or data rate for an application. This implies a choice of signal types, either analog or digital, since even a simple point-to-point link will employ appropriate hardware. The goal is to establish what optical power level will be required at the optical detector inside the receiver unit.

As shown in Figure 16, fiber can handle either analog or digital transmission and it offers the additional option of future upgrading by simply changing the electronics hardware at the transmitter and receiver ends. For this reason most fiber system designers specify more fiber bandwidth capacity than is minimally required.

Analog Signals:

Analog signal such as video and audio can be directly modulate optical output by causing the optical emitter to brighten and dim. This is called intensity modulation and is a simple and straightforward method of encoding lightwave signals.

Improvements in both signal-to-noise and linearity can be obtained by the use of frequency modulation (FM) techniques. Here the information source is used to frequency modulate a subcarrier, then this signal is used to intensity modulate an LED or laser. Because of material and intermodal dispersion factors, FM links normally require fibers with bandwidths of 200 MHz-km and higher. Short unrepeatable links are occasionally analog modulation. However most lightwave applications today use digital transmission with simple on-off modulation.

Digital Signals:

In fiber optics, a digital pulse can be formed by turning the source "on" for a brief instant. The time of optical radiation emission is the pulse. A binary "1" state can be used to represent optical power turned "on", while a binary "0" state is used to represent "off". These two states represent binary signals. Digital signals consist of a series of bits that result in the emitter being "on" or "off" as shown in Figure 17.

The time it takes for a pulse to reach full amplitude is the rise time. Faster rise and fall times allow more pulses per second, consequently more bits of information can be transmitted.

In digital systems one parameter for system performance is bit error rate (BER). The majority of digital systems achieve a BER of 1×10^{-9} (1 error in 10^9 bits)

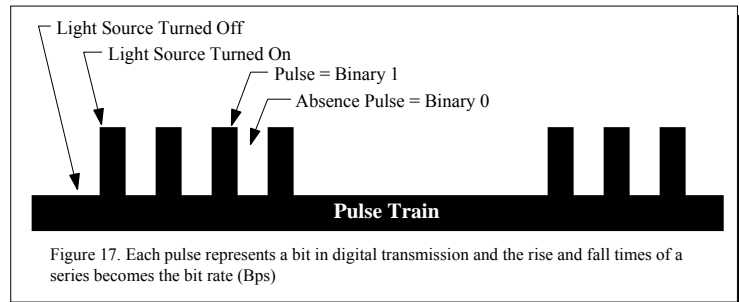
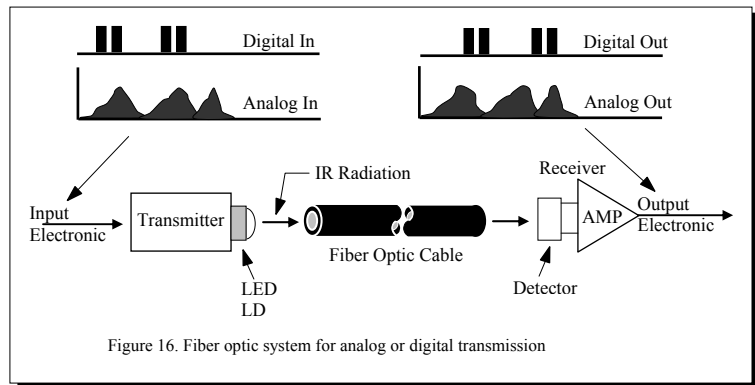

System Design Procedure (Continued)

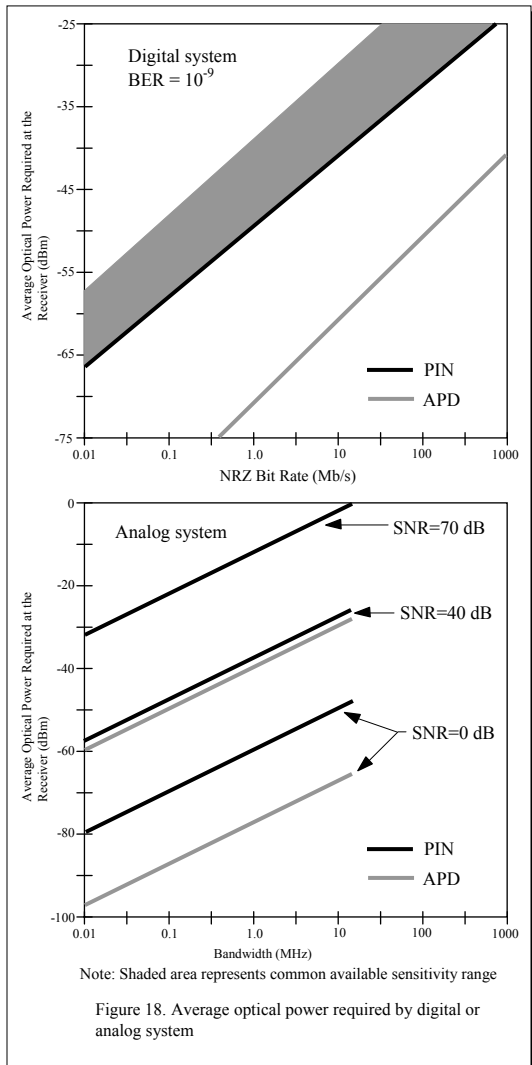

There is a length dependence with digital systems because the farther a pulse has to travel down a fiber the more distortion occurs. The resulting optical power level required at the detector is a function of the data rate or bandwidth. These levels for digital and analog signals are indicated for silicon detectors at 850 nm in Figure 18.

Once the application (TV, telephone, or computer), the type of signals (analog, digital), and the data rate have been determined, the next step is to describe the physical layout and environmental requirements.

System Layout: (Step2)

To determine the components necessary to complete a fiber optic system requires detailing run lengths and determining system operating environments.

A simple point-to-point system as shown in Figure 19, or a more elaborate local area network involving telephone, data, video, control and alarm functions as shown in Figure 20, are both becoming commonplace installations for fiber optic cable. Current fiber optic technology employs a separate fiber to transmit the signals in one direction.

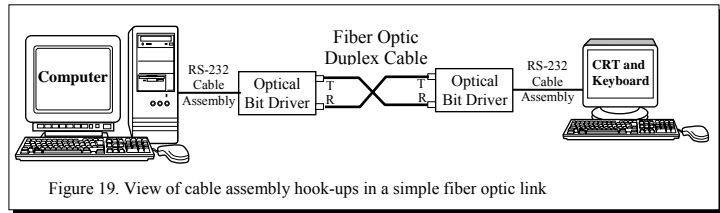

Figure 19. View of cable assembly hook-ups in a simple fiber optic link

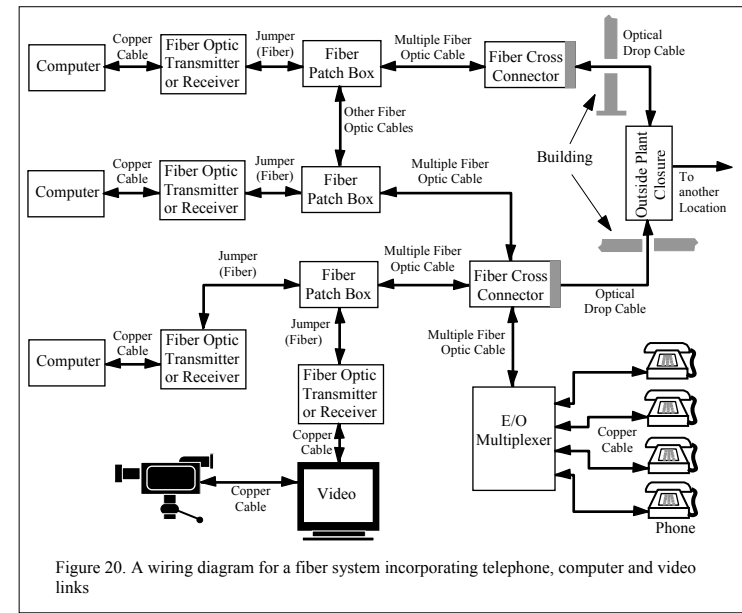

Figure 20. A wiring diagram for a fiber system incorporating telephone, computer and video links

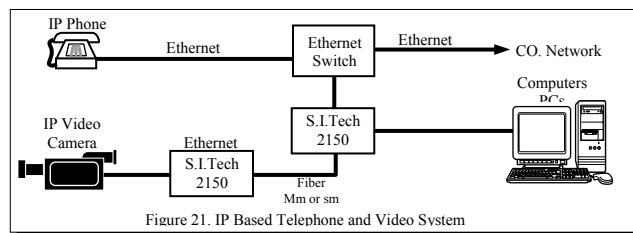
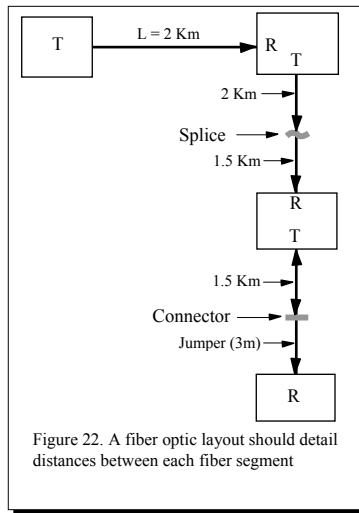

Figure 21. IP Based Telephone and Video System

Therefore most point-to-point systems will require at least two fibers for duplex communications. Higher fiber count cables are also readily available.

The system designer should develop a layout schematic similar to the one shown in Figure 20 and use the resulting information on the worksheets at the back of this brochure.

System Design Procedure (Continued)



Signal Optical Power Budget: (Step 3)

With the system layout and components known, it's now possible for the designer to compute expected losses at each point in the system as shown in Figure 23.

Every component including fiber has a range of optical loss due to variations in manufacture. An LED device, for example, will be specified with a minimum, average, and maximum optical output power. The range may be as much as 4 dB (60%).

Detectors also have sensitive ranges. It is up to the system designer to determine the optical power necessary at the detector surface from information supplied by the manufacturer.

Once the receiver and transmitter power levels have been established it is possible to consider the power transmitted by various cable lengths. This can be seen by plotting the power on a diagram such as in Figure 24.

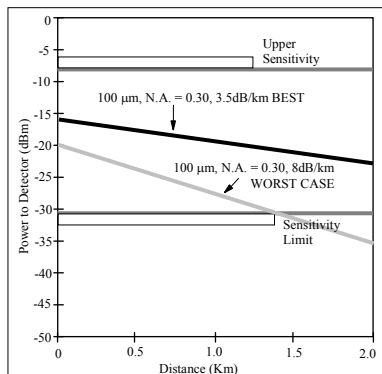
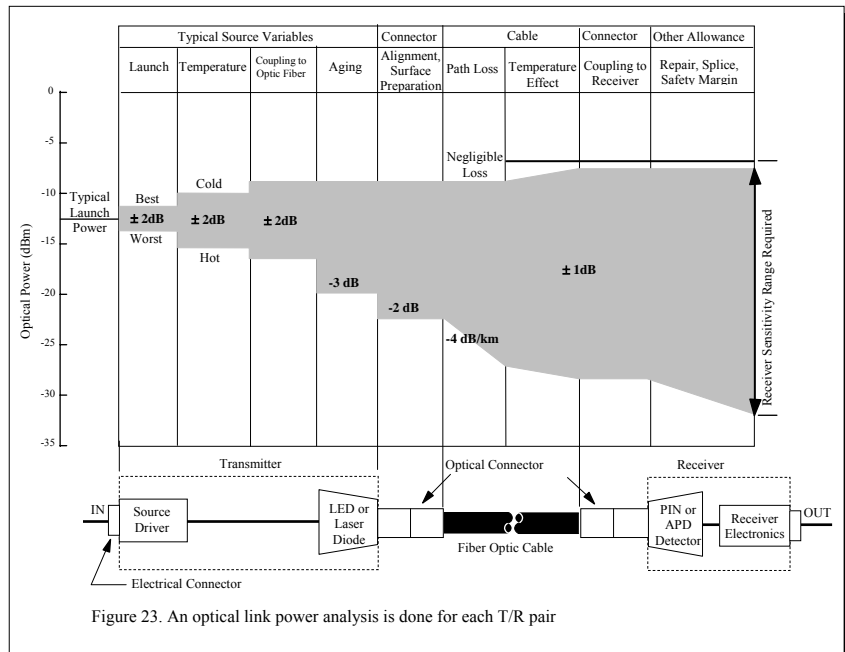

Figure 24. Use stated receiver and transmitter ranges to determine fiber distances (e.g. 10 Mb/s transmitter at 850 nm 100 micron core fiber)



In the example shown, a fiber with a 100 micron core has been analyzed for use with a 10 Mb/s transmitter at the 850 nm wavelength. Both the best and worst case curves are shown with the average expected range in between.

The detector sensitivity upper and lower limits are also shown. This figure indicates that a transmission distance of about 1.4 km is maximum.

The same technique can be used to compare two fiber core sizes as shown in Figure 24. Here the 50/125 fiber is acceptable if the maximum length is less than 0.5 km.

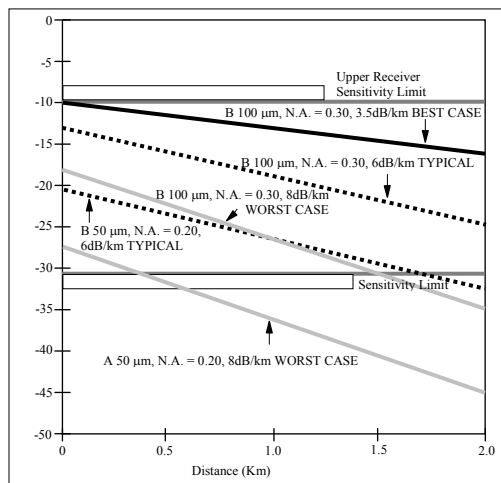
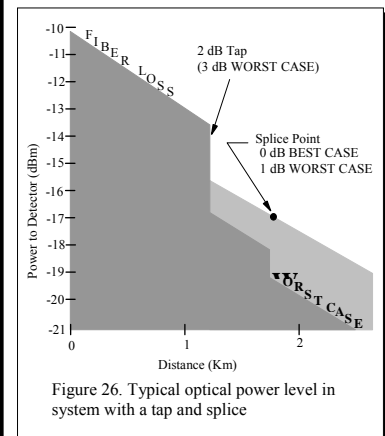

Figure 25. Fiber distance compared for two core size: 50 micron and 100 micron at 850 nm wavelength and 10Mb/s

Starting power levels vary due to the emitter launch range. When taps and splices are included, their values can be considered as part of the launch loss, or displayed where they might occur in the system as in Figure 26.

Worksheets are included at the end of this brochure for determining your optical power budget. Use either peak or average optical power values for determining attenuation throughout the system. Be consistent in your choice throughout the system analysis.



System Design Procedure (Continued)

Power couple to various fiber types by a few typical source emitters is detailed in Figure 27. Coupled power for each fiber type under consideration should be entered in the appropriate column on the worksheet. Allow approximately 4 to 6 dB to account for thermal variations in the optical fiber, repair of damaged cable, and source degradation over time.

Fiber Selection:

Basic fiber types are presented in Figure 28. The various fiber properties such as attenuation, numerical aperture (NA), core diameter have all been covered earlier in this brochure. NA and core diameter must be considered for launch conditions. All fibers can be compared over one kilometer lengths for fiber properties and relative optical power as in Table 4.

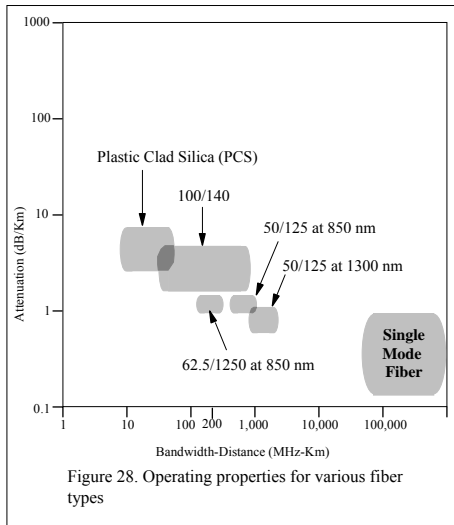

Figure 28. Operating properties for various fiber types

Certain fiber types have proven suitable for special applications.

Choices for most LAN or data systems, for example, currently centers on the all-silica fibers. Here various core/cladding constructions are available with tradeoffs in performance, cost, and standardization. In past four sizes are most often were considered. 50 micron fiber is now available with laser enhanced performance at 850nm.

Core	Cladding	Bandwidth	
		850	1300
50	125	600	600
62.5	125	200	500
85	125	200	600
100	125	150	500

All are multimode, graded-index fibers to assure adequate bandwidth and low enough loss to be ideal for typical LAN capacity Video and CATV systems often employ 50/125 and single mode fibers because of their high bandwidth and low loss performance characteristics. Modern intercity telephone trunks also employ single mode fibers.

Fibers may be selected in a variety of bandwidths and attenuations, in either one or two window versions. Again, attenuation of optical fibers will vary depending on the source wavelength of the transmitter. A fiber cable loss table for Belden products is shown in Table 5, and can be used with the Step 3 Worksheet at the end of this brochure.

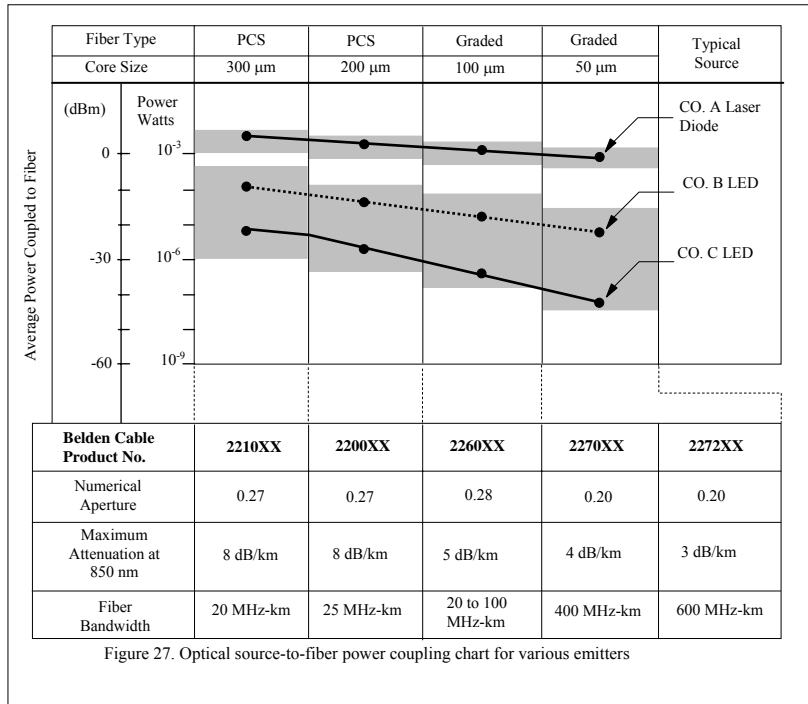

Figure 27. Optical source-to-fiber power coupling chart for various emitters

Type of Fiber		Numerical Aperture	Relative Collection Factor (dB) ¹	Relative Optical Power (dB) at 1 km ²
Material Structure	Type			
Silica	Single Mode	0.08	-31.0 ³	-28.0
Silica	Multimode	0.20	-8.9	-6.9
Silica	Multimode	0.29	-3.8	-2.8
Silica	Multimode	0.26	-2.1	-1.1
Silica	Multimode	0.28	0.0	0.0
PCS	Multimode	0.27	+5.7	+3.7
PCS	Multimode	0.27	+9.2	+7.2

1. Relative amount of radiation coupled to fiber based on 1 km length NA value. Shorter lengths may have higher values.
2. Based on the difference in transmission over a 1 km length of cable using the 100 micron core fiber at 5 dB/km (850 nm) as the basis for normalization.
3. Primary use at 1300 nm or 1550 nm.

Table 4. Optical power comparison for various fiber types

Material Structure	Core Dia. Micron (µm)	Numerical Aperture	Attn * DB/km	Bandwidth MHz/km
Silica	50	0.20	4	400
Silica	50	0.20	3	600
Silica	62.5	0.29	4	200
Silica	85	0.26	4	200
Silica	100	0.28	5	100
PCS	200	0.27	7	25
PCS	300	0.27	7	20

*Values for 850 nm wavelength

Table 5. Typical optical fiber cable performance

System Design Procedure (Continued)

Bandwidth Analysis: (Step 4)

While attenuation is one major determinant in fiber optic system performance, bandwidth is the other. Here the goal is to assure that all components have sufficient bandwidth to transmit the required signal. Local area networks typically require 20 to 600 MHz-km fiber bandwidth. On the other hand, long-haul telephone systems employ large distance between repeaters and require the 100,000 MHz-km bandwidths associated with single mode fiber.

A fiber has a 3dB (half power) optical signal magnitude decrease at the bandwidth specified for that fiber. Conversion between electrical and optical bandwidth for the system or any component such as a fiber, receiver, or transmitter unit is performed by using: $BW_{optical} = 1.41 BW_{electrical}$. In some cases a receiver or transmitter manufacturer will specify risetimes. The electrical bandwidth (BW in MHz) for a component is related to its 10% - 90% risetime (t in nanoseconds) by: $BW = 350/t$ and the total system electrical bandwidth is obtained from individual component bandwidth by:

$$\frac{1}{BW^2} = \frac{1}{BW_R^2} + \frac{1}{BW_C^2} + \frac{1}{BW_T^2}$$

Where BW_R , BW_C and BW_T are the electrical bandwidth of the receiver, cable and transmitter respectively.

For digital systems the system bandwidth will depend on the data rate (R in bits per second) and the coding format according to:

$$BW_{system} = R/K$$

Where K equals 1.4 for a non-return-to-zero (NRZ) coding format and 1.0 for a return-to-zero (RZ) format.

The system bandwidth is limited by the lowest bandwidth component in the link. When high bandwidth fiber is used for example, the system frequency response may be more influenced by the terminal equipment than the fiber.

A general guideline in selecting the terminal equipment is to choose a receiver with a bandwidth equal to or greater than the required system bandwidth. The transmitter and optical fiber should then have bandwidths about 1.5 to 2 times greater than the receiver.

Again, systems are usually more cost effective at higher data rates. And allowing for more fiber bandwidth than is minimally required, for example, allows system capacity to be upgraded later. Care should be taken in estimating the optical bandwidth in MHz-km of series connected cable runs with lengths greater than a kilometer.

The approximate relationship between the total cable bandwidth (BW_{CO}) and one kilometer section fiber bandwidth (BW_f) is:

$$BW_f = BW_{CO} (L)^x$$

L is the fiber length in kilometers. The x equals 1.0 for cable run lengths (L) of one kilometer or less. And x equals 0.75 for fiber in cable run lengths greater than one kilometer.

The Step 4 Worksheet provides a simple example and a blank form to fill in the necessary values for a bandwidth analysis. Here the $1/BW^2$ terms are individually calculated and then combined in a series of steps to yield the total system bandwidth.

System Review: (Step 5)

Now is the time for the system designer to review all of the pieces to determine that all work together to deliver the right signal to the right place at the right time. These combined parameters can be listed Step 5 Worksheet.

The complete cable structure can be established using the following criteria:

- Cable Construction
Hybrid _____ All Dielectric _____
Metal Strength Members _____
Indoor _____ Outdoor _____
Armored _____
- Jacket Materials
PVC _____ Polyurethane _____
Polyethylene _____ Other _____
- Environmental Protection
Flame Retardancy _____
Or UL code _____
Sunlight Resistance _____
Abrasion Resistance _____
Water Blocking (gel fill) _____
Rodent Protection (armor) _____
Nuclear Radiation Resistance _____
Other _____
- Chemical Resistance
To Oil _____, Acid _____
Alkali _____, Solvents _____

- Fiber Features
Number of Fibers _____
Fiber Type _____ Core Size _____
Wavelength _____
Attenuation _____
Bandwidth _____
NA _____
Double Window _____
- Number and Type of Electrical Connectors _____

Specific materials and multi-fiber constructions have resulted in numerous cable designs which incorporate a variety of fibers to meet specific applications. Hybrid designs having both optical fibers and metallic conductors.

Hopefully this guide will permit the identification and description of a useful fiber optic system. Due to advancing technology and extensive tradeoffs, system design is constantly changing. This guide is based on currently available components. To keep abreast of changes, ask questions, or to request design assistance, contact Belden's local sales representative or the regional offices listed on the back cover of this booklet.

Worksheets

Step 1. System Operational Requirements

Application

Video _____ Telecom/WAN _____ Computer/LAN _____ Industrial _____ Other _____

Type of Signals

Analog:

- System Bandwidth _____ MHz
- System Signal-to-Noise Ratio _____ dB

Digital:

- Coding Scheme NRZ _____ RZ _____ Other _____
- Data Rate _____ Bits Per Second
- Bit Error Rate 10^{-8} _____ 10^{-9} _____ Other _____
- Logic Format _____ TTL _____ ECL _____
Other _____

Optical:

- (A) Minimum Required Optical Power _____ dBm Average _____ Peak _____
(from manufacturer's data)
 - (R) Receiver Dynamic Range (from manufacturer's data) _____ dBm
 - (S) Maximum Optical Power allowed at receiver (A+R) _____ dBm Average _____ Peak _____
- Number of Channels _____

Terminal Equipment

Space available for:

Transmitter _____ " x _____ " x _____ "

Receiver _____ " x _____ " x _____ "

Repeater _____ " x _____ " x _____ "

Terminal Equipment Connections RS-232 _____ RS-422 _____ RS-485 _____ Twinax _____ TP Ethernet _____ USB _____ Other _____

Terminal Equipment Mounting PC Board _____ Rack _____ Dinrail _____ Standalone _____ Other _____

Power Supply Requirements:

Voltages AC _____ DC _____

Current _____ mA

Frequency _____ Hz

Step 2: System Layout

System Location

Locations of Equipment Building _____ Other _____

Distance Between Stations Meters _____

Routing Plan for Cables _____

System Environment

For Terminals and Repeaters Indoor _____ Outdoor _____

For Cables (based on routing) Ducts _____ Buried _____ Aerial _____ Other _____

Temperature Range _____ °C to _____ °C

High Voltage Present Yes _____ No _____ Volts _____

Water Presence Yes _____ No _____

Installation Constraints

Installation Equipment _____

Cable Pull Lengths _____ Meters

Worksheets (Continued)

Step 3. Signal Optical Power Budget

Example:

	Required Bandwidth (Data Rate)	(NRZ, 1.4 Mbps)
	Required Bit Error Rate	10^{-9}
(L)	Required Length of Run	2 Km
(A)	Minimum Optical Power Required for PIN Type Receiver	-39 dBm Average
(R)	Receiver Dynamic Range	20 dB
	Maximum Optical Power Allowed at Receiver (A+R)	-19 dBm
	Transmitter Type (Wavelength)	LED 850 nm

	Source-to-Fiber Coupling: Fiber (Core Diameter)	200 μm	100 μm	62.5 μm
(B)	Coupled Power (From Figure 26)	-5 dBm	-11 dBm	-20 dBm
(C)	Power Difference (B-A)	34 dB	28 dB	19 dB
(D)	Degradation Allowance	6 dB	6 dB	6 dB
(E)	Power Margin (C-D)	28 dB	22 dB	13 dB
(F)	2 Connectors (Average Loss: 0.5 to 3dB/Connector)	6 dB	1 dB	1 dB
(G)	0 Splice (Average Loss: 0.25 dB/splice)	0 dB	0 dB	0 dB
(H)	Maximum Cable Attenuation Allowed (E-F-G)	22 dB	21 dB	12 dB
(I)	Cable Attenuation at 850 nm (From chart in Figure 26)	8 dB/Km	6 dB/Km	5 dB/Km
(J)	Total Cable Loss (I x L)	16 dB	12 dB	10 dB
	Maximum cable Length Allowed (H/I)	2.75 Km	3.5 Km	2.4 Km
(K)	Excess Power Margin	6 dB	9 dB	2 dB

Worksheet:

	Required Bandwidth (Data Rate)	_____		
	Required Bit Error Rate	_____		
(L)	Required Length of Run	_____ Km		
(A)	Minimum Optical Power Required for _____ Receiver	_____ dBm	Average	Peak
(R)	Receiver Dynamic Range	_____ dB		
	Maximum Optical Power Allowed at Receiver (A+R)	_____ dBm		
	Transmitter Type (Wavelength)	_____ nm	Laser Diode (nm)	Other Source (nm)

	Source-to-Fiber Coupling: Fiber (Core Diameter)	μm	μm	μm
(B)	Coupled Power (From Figure 26)	_____ dBm	_____ dBm	_____ dBm
(C)	Power Difference (B-A)	_____ dB	_____ dB	_____ dB
(D)	Degradation Allowance	_____ dB	_____ dB	_____ dB
(E)	Power Margin (C-D)	_____ dB	_____ dB	_____ dB
(F)	Connectors (Average Loss: _____ dB/Connector)	_____ dB	_____ dB	_____ dB
(G)	Splice (Average Loss: _____ dB/splice)	_____ dB	_____ dB	_____ dB
(H)	Maximum Cable Attenuation Allowed (E-F-G)	_____ dB	_____ dB	_____ dB
(I)	Cable Attenuation at 850 nm (From chart in Figure 26)	_____ dB/Km	_____ dB/Km	_____ dB/Km
(J)	Total Cable Loss (I x L)	_____ dB	_____ dB	_____ dB
	Maximum cable Length Allowed (H/I)	_____ Km	_____ Km	_____ Km
(K)	Excess Power Margin	_____ dB	_____ dB	_____ dB

Worksheets (Continued)

Step 4. Signal Bandwidth Analysis

Example:

Receiver Bandwidth PIN Type: $BW_R = 10 \text{ Mhz}$
 (A) $1/BW_R^2 = 10^{-2} \text{ MHz}^{-2}$
 Transmitter Bandwidth LED Type: $BW_T = 20 \text{ Mhz}$
 (B) $1/BW_T^2 = 2.5 \times 10^{-3} \text{ MHz}^{-2}$
 Fiber Optic Cable Bandwidth
 (C) Fiber Length $L = 2 \text{ Km}$

Fiber (Core Diameter Type)		200 μm	100 μm	62.5 μm
(D)	Bandwidth BW_f	25 MHz-Km	20 MHz-Km	200 MHz-Km
(E)	Cable Optical Bandwidth BW_{CO}	12.5 MHz	11.9 MHz	118.9 MHz
(F)	Cable Electrical Bandwidth BW_C (E/1.41)	8.9 MHz	8.4 MHz	84.3 MHz
(G)	$1/BW_C^2$	$1.3 \times 10^{-2} \text{ MHz}^{-2}$	$1.4 \times 10^{-2} \text{ MHz}^{-2}$	$1.4 \times 10^{-2} \text{ MHz}^{-2}$
System Bandwidth				
(H)	Sum of Squares (A+B+G)	$2.5 \times 10^{-2} \text{ MHz}^{-2}$	$2.6 \times 10^{-2} \text{ MHz}^{-2}$	$1.3 \times 10^{-2} \text{ MHz}^{-2}$
(I)	System Bandwidth $1/\sqrt{H}$	6.3 MHz	6.2 MHz	8.8 MHz
(J)	Required System Bandwidth	1.0 MHz	1.0 MHz	1.0 MHz
(K)	Bandwidth Margin (I-J)	5.3 MHz	5.2 MHz	7.8 MHz

Worksheet:

Receiver Bandwidth ___ Type: $BW_R = \underline{\hspace{2cm}} \text{ Mhz}$
 (A) $1/BW_R^2 = \underline{\hspace{2cm}} \text{ MHz}^{-2}$
 Transmitter Bandwidth ___ Type: $BW_T = \underline{\hspace{2cm}} \text{ Mhz}$
 (B) $1/BW_T^2 = \underline{\hspace{2cm}} \text{ MHz}^{-2}$
 Fiber Optic Cable Bandwidth
 (C) Fiber Length $L = \underline{\hspace{2cm}}$

Fiber (Core Diameter Type)				
(D)	Bandwidth BW_f	MHz-Km	MHz-Km	MHz-Km
(E)	Cable Optical Bandwidth BW_{CO}	MHz	MHz	MHz
(F)	Cable Electrical Bandwidth BW_C (E/1.41)	MHz	MHz	MHz
(G)	$1/BW_C^2$	MHz^{-2}	MHz^{-2}	MHz^{-2}
System Bandwidth				
(H)	Sum of Squares (A+B+G)	MHz^{-2}	MHz^{-2}	MHz^{-2}
(I)	System Bandwidth $1/\sqrt{H}$	MHz	MHz	MHz
(J)	Required System Bandwidth	MHz	MHz	MHz
(K)	Bandwidth Margin (I-J)	MHz	MHz	MHz

Worksheets (Continued)

Step 5. System Review

System Considerations	Example	Requirements for Operation
Data Rate (Bandwidth)	1.4 Mbps (1.0 MHz)	
Signal-to-Noise Ratio (Analog)		
Bit Error Rate (Digital)	10 ⁻⁹	
Coding Scheme (Digital)	NRZ	
Receiver		
Type	PIN	
Bandwidth	10 MHz	
Sensitivity		
Minimum Optical Power	-39 dBm Average	
Bit Error Rate	10 ⁻⁹	
Dynamic Range	20 dB	
Transmitter		
Bandwidth	20 MHz	
Coupled Optical Power	-5 dBm	
Wavelength/Type	850 nm/LED	
Optical Fiber		
Fiber Type	200 μm core	
Bandwidth	25 MHz-Km	
Attenuation (at Transmitter Source Wavelength)	8 dB/Km	
Fiber Length	2 Km	
Number of Splices	0	
Total Splice Attenuation	0 dB	
Number of Connectors	2	
Total Connector Attenuation	6 dB	
Degradation Allowance	6 dB	
Bandwidth Margin	5.3 MHz	
Excess Power Margin	6 dB	

Step 6. System Costs

The cost of each component should be totaled to determine the system cost.

_____	QTY				
_____		Connectors at \$ _____	/connector	= \$	_____
_____		Transmitters at \$ _____	/transmitter	= \$	_____
_____		Receivers at \$ _____	/receiver	= \$	_____
_____		Km of Cable at \$ _____	/kilometer	= \$	_____
_____		Repeaters at \$ _____	/repeater	= \$	_____
		Installation Costs		= \$	_____
		Maintenance Costs		= \$	_____
		Other Costs		= \$	_____
		Total System Costs		= \$	_____