

Profibus - DP Fiber Optic Ring Bit-Driver



Features:

- Meets PROFIBUS-DP specification. **Tested & approved by PROFIBUS Lab**
- Multimode and single mode
- Plastic or glass fiber
- 2 port optical repeater, optical T-connector, optical to electrical converter
- 9600 bps to 12 Mbps - Auto Negotiation - visual indicators
- DIN rail mounting
- Status indicators: Activity and Error Condition on each port
- **Redundant ring**
- **Data speed display**
- **Auto negotiation**

The Model 2147 Bit-Driver used in a PROFIBUS-DP application is a two fiber optic port repeater with single TIA/EIA-485-A electrical port. The 2147 operates at rate 9600 baud to 12 Mbaud in linear bus topology. The 2147 can be used as an optical repeater between the fiber optic segments, an optical to electrical converter between a fiber optic segment and electrical station(s), or T-connector/repeater between two fiber optic segments and electrical station(s). The 2147 is transparent and does not evaluate the PROFIBUS data exchange. Model 2147 can be configured to operate in redundant ring topology.

Using fiber optics over the physical layer, the 2147 provides longer segment distances, electromagnetic noise immunity, and ground potential difference independence in the linear bus topology. The 2147 can be optionally equipped with optics of different characteristics.

The 2147 retimes the received optical signal and can link up to 32 fiber optic segments in series. The electrical port supports up to 31 stations.

The 2147 Termination switch can select an internal cable type-A termination. External terminations can derive power from the sub-D connector between pins 6 and 5.

The 2147 unit attaches to EN50022 (35mm DIN) mounting rail. Redundant power is applied through screw terminals and data rate selection made automatically with visual indicator of speed display.

Operation Mode: RS485 - 2 wire
Profibus - DP

Input/Output Interface: EIA RS485A 2 wire
9600bps to 12Mbps
IEC 61158-2, Async, NRZ, 11 Bits
DB9 female

Transmission Line Interface: ST Connectors-standard (SMA option)

Optical Power (TR): See table 1

Receiver Sensitivity: See table 1

Operating Temperature: -25°C to +70°C
(-20°C to +60°C for SM)

Metal Enclosure: DIN Rail Mounting
Size: 4.2"X4.8"X1.7" (10.7X12.2X4.3 cm)

Weight: 1.25 lb (568 grams)

Input Power: 24VDC, 3 Watts, Terminal block
Redundant Input

Electrical Isolation: 1500V

Conducted Emissions: EN55022 Class B

Mechanical: IP 40

TABLE 1

Model	Wavelength (nm)	Fiber Diameter (Micron)	Fiber Type	Connector	TR PWR (-dBm)	REC SEN (-dBm)	Attenuation dB/Km	Distance Meters	Distance Feet	OPT Ports
2147-0	660/850	200	Plastic	BFOC/2.5 (St)	10	22	10/7	700/1000	2000/3000	2 PL
2147-00	660	1000	Plastic	BFOC/2.5 (ST)	7	20	200	100	330	2 PL
2147-MM	850	50 or 62.5	Multimode	BFOC/2.5 (ST)	12	24	3.0	3000	10000	1 MM
2147 or 2147-MM-MM	850	50 or 62.5	Multimode	BFOC/2.5 (ST)	12	24	3.0	3000	10000	2 MM
2147-MM-SM	850/1300	50 or 62.5/9	MM/SM	BFOC/2.5 (ST)	12/15	24/27	3.0/1.0	3000/10000	10000/33000	1 MM, 1 SM
2147-SM-SM	1300	9	SM/SM	BFOC/2.5 (ST)	15	27	0.35	10000	33000	2 SM
2147-SM	1300	9	Single Mode	BFOC/2.5 (ST)	15	27	0.35	10000	33000	1 SM

Note: Plastic fiber can be used for short distance applications.

Meets FCC requirements of Class A, Part 15 Computing Devices Standard.

Specifications subject to change without notice.



TYPICAL APPLICATION

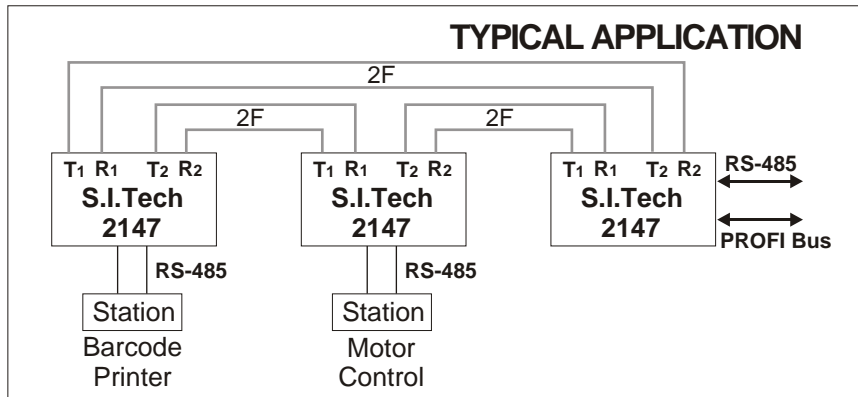

RS - 485 DB9 FEMALE CONNECTOR PINOUT

Sub-D	Signal Name	Function
1	Shield	Protective Ground
2	--	--
3	RxD/TxD-P	Data-P (B-Line)
4	--	--
5	DGND	Data Ground
6	VP	Voltage Plus (+5VDC)
7	--	--
8	RxD/TxD-N	Data-N (A-Line)
9	--	--
Body	Shield	Protective Ground