

# S.I. TECH

## Fiber Optic Communication Products

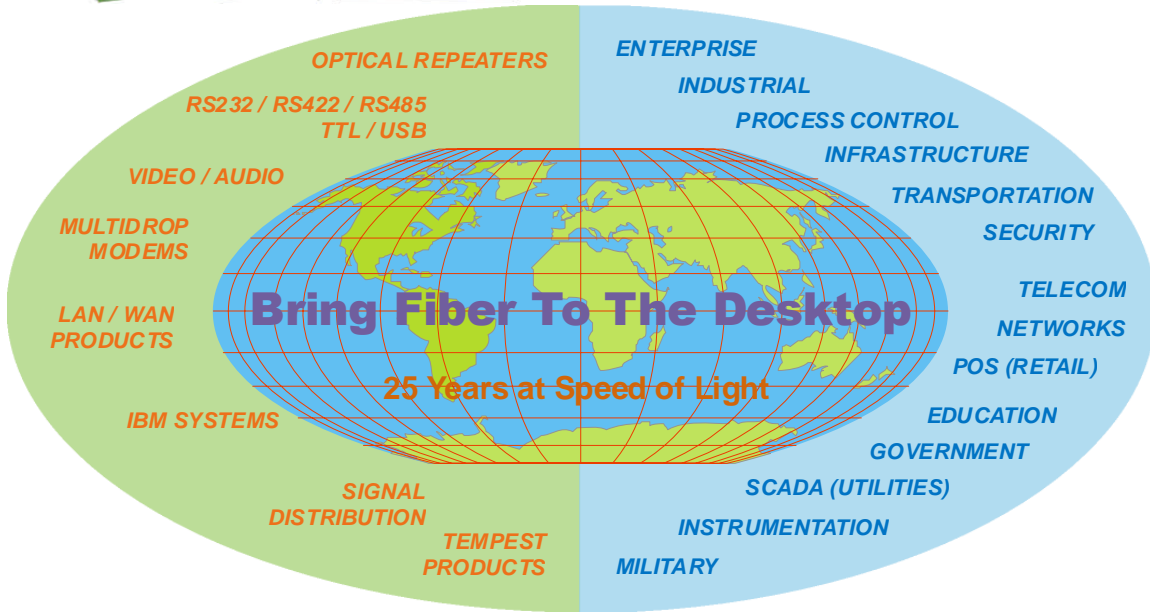
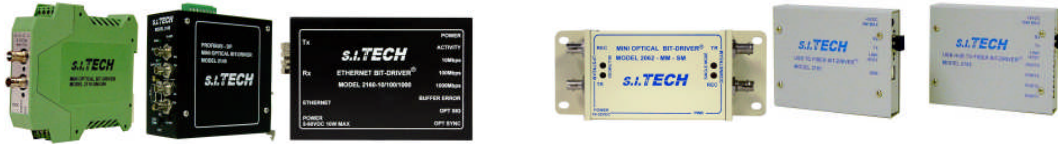

ISO9001

USA & INTERNATIONAL HEADQUARTERS  
 1101 N. RADDANT ROAD • BATAVIA • IL 60510  
 PO BOX 609 • GENEVA • IL 60134  
 NATIONWIDE TOLLFREE 1-866-SITECH-1 [(866) 748-3241]  
 PHONE: (630) 761-3640 • FAX: (630) 761-3644  
 WEB SITE: <http://www.sitech-bitdriver.com>  
 E-MAIL: [sales@sitech-bitdriver.com](mailto:sales@sitech-bitdriver.com)

# S.I. TECH

**...an early innovator  
in the fiber optics  
industry**

Along with the rapidly increasing use of computers and computer-driven equipment, there has been a rising demand for faster, higher quality (error-free) data communications. Fiber optics technology is the answer.

S.I. Tech has been on the leading edge of this technology since its early years. The founder of S.I. Tech managed Belden Corporation's new venture development activity in fiber optics. S.I. Tech acquired Belden's fiber optic systems business in 1984 and Honeywell's fiber optics multiplexer business in 1988.

**Factory-trained  
distributors  
worldwide make  
S.I. Tech your local  
source.**

An early entrant in the industry, S.I. Tech has developed numerous well known fiber optic products and application engineering solutions for customers worldwide. Its products today are sold and supported on all five continents. They are performing in a wide variety of applications and environments from Alaska to Australia. "Mission critical" applications everywhere depend on S.I. Tech – from oil rigs somewhere in Asia to a factory in Europe or a university in the United States.

To be close to its global customer base, S.I. Tech works closely with a select group of distributors, system integrators and other value-added resellers. These extensions of S.I. Tech are your "local" source for quality products and technical assistance.

## S.I. Tech Offers:

- *Technical Support*
- *Customer Service*
- *Research & Development*
- *Network Solutions*
- *Quality Assurance Testing*
- *All Products Apply to Industry Standards*
- *Product Availability Worldwide*
- *All Products Manufactured in the USA*



## For information or to place an order:

USA & INTERNATIONAL HEADQUARTERS  
1101 N. RADDANT ROAD • BATAVIA • IL 60510  
PO BOX 609 • GENEVA • IL 60134  
NATIONWIDE TOLLFREE 1-866-SITECH-1 [(866) 748-3241]  
PHONE: (630) 761-3640 • FAX: (630) 761-3644  
WEB SITE: <http://www.sitech-bitdriver.com>  
E-MAIL: [sales@sitech-bitdriver.com](mailto:sales@sitech-bitdriver.com)

## Catalog Index

Section	Category	Page Numbers
1	RS232 Products	p. 5-22
2	RS422 Products	p. 23-34
3	RS485 Products	p. 35-44
4	TTL Products	p. 45-50
5	Video, Audio, & Alarm Products	p. 51-60
6	USB Products	p. 61-68
7	LAN/WAN Products	p. 69-86
8	Fiber Optic Products for IBM Systems	p. 87-94
9	Signal Distribution Systems	p. 95-98
10	Accessories	p. 99-102
11	Wave Division Multiplexers (WDM)	p. 103-104
12	Bit Driver Packaging	p. 105
13	Power Options and How to Order	p. 106
14	Bit-Driver Mounting Options	p. 107-108
15	Fiber Optic System Design	p. 109-126
16	Terms & Conditions	p. 127-128
17	Glossary of Terms	p. 129-138
18	Industry Standards	p. 139-140
19	Warranty	p. 141

## Product Listing

RS232 Products		RS422 Products		TTL Products		USB Products	
Model No.	Page	Model No.	Page	Model No.	Page	Model No.	Page
2004	12	2116	28	2860*	49	212005*	65
2005	12	2176	28	2865*	49	2174*	65
2036	12	2322	29	2867*	49	2175*	66
2109	12	2376	29	<b>TTL Multiplexers</b>		2181*	66
2139*	12	2857	29	Model No.	Page	2182*	66
2282*	12	HFS 1172-132	29	2006	50	USB1.0 Kit #4*	66
2304	13	HFS 1176-192	29	HFS 1175-546	50	USB2.0 Kit #11*	67
2305	13	2140*	30	<b>Video Products</b>		USB2.0 Wireless Kit #16*	67
2360*	13	2281*	30	Model No.	Page	212106*	67
2503	13	2561*	30	2379*	54	212110*	67
2505	13	2563*	30	2380*	54	<b>Ethernet Products</b>	
2506	13	2859*	30	2509-IL*	54	Model No.	Page
2507	14	2860*	30	2809	54	2150-10/100A*	78
2557*	14	2867*	31	2810	54	2160*	78
2560*	14	575-0656-004 & 005	31	2823	55	2350-10/100A*	78
2563*	14	Kit #9*	31	2824	55	2350	78
2607*	14	<b>RS422 Multiplexers</b>		2829*	55	2361-10/100/1000*	78
2617*	14	Model No.	page	Kit #6*	55	2550	79
2834*	15	2424	33	Kit #15*	55	2703*	79
3503	15	2428	33	HFS 1142	56	3150*	79
Kit #1*	15	<b>RS485 Products</b>		HFS 1144	56	3152*	79
Kit #8*	15	2110	40	HFS 1146	56	3160*	79
Kit #17*	15	212110*	40	<b>Audio (Analog) Products</b>		10 Mbps Ethernet Kit #2*	79
<b>RS232 Metallic Products</b>		2126	40	Model No.	Page	10/100 Ethernet Kit #3*	80
Model No.	Page	2127	40	2237T*	57	10/100/1000 Ethernet Kit #12*	80
2025	17	2128	40	2237R*	57	<b>Fiber Optic Repeaters</b>	
2526	17	2128/2228	40	2239*	57	Model No.	Page
2527	17	2140*	41	HFS 1151	57	2062	83
212005*	17	2145*	41	HFS 1152	57	2082*	83
9338	17	2310	41	HFS 1153	57	<b>LAN/WAN Products</b>	
2282*	18	2316*	41	Kit #5*	58	Model No.	Page
<b>RS232 Multiplexers</b>		2345	41	<b>Alarm Products</b>		2353	83
Model No.	Page	2562*	41	Model No.	Page	2853	83
1000	20	2563*	42	2311*	59	9024	83
2006	20	2610*	42	2312*	59	2390	85
2007	20	2616*	42	2811	59	2391*	85
2016	20	2852	42	2812	59	2890	85
2016-O*	20	Kit #10*	42	2813	59	2890-2R-ASP-1*	85
2017	21	<b>RS485 Multiplexers</b>		AESFOT Kit*	60	2890-4R-ASP-1*	85
2216	21	Model No.	Page	<b>USB Product</b>		2891	86
<b>RS232 Modem Splitter</b>		2454	44	Model No.	Page	2893*	86
Model No.	Page	2458	44	2170*	64	2894*	86
9703*	22	<b>TTL Products</b>		2171*	64	2895*	86
9706*	22	Model No.	Page	2172*	64	2896*	86
9718*	22	2856	48	2173*	64	<b>Products for IBM Systems</b>	
<b>RS422 Products</b>		575-0656-006	48	2179*	64	Model No.	Page
Model No.	Page	575-0656-007	48	3170*	65	2336	92
2012	28	2805 Dip Models	48	3171*	65	2836	92
2106	28	2806 Dip Models	48	3172*	65	9036	92
212106*	28	2817*	48	3173*	65	9302	92

## Product Listing

Products for IBM Systems		Signal Distribution Systems		WDMs	
<i>Model No.</i>	<i>Page</i>	<i>Model No.</i>	<i>Page</i>	<i>Model No.</i>	<i>Page</i>
9304	92	3001*	97	8513	104
9308	92	3000AESFOT*	97	1315	104
2370*	94	<b>Accessories</b>		9951	104
2870	94	Fiber Cable Assemblies	100		
3799	94	Fiber Optic Components	101		
2129	94				
<b>Signal Distribution Systems</b>					
<i>Model No.</i>	<i>Page</i>				
Series 1000 Non Muxed	97				
Series 3000	97				
9024	97				

\* Indicates a new product



## **RS-232 Products**

## RS-232 PRODUCTS

### 1. Point to Point:

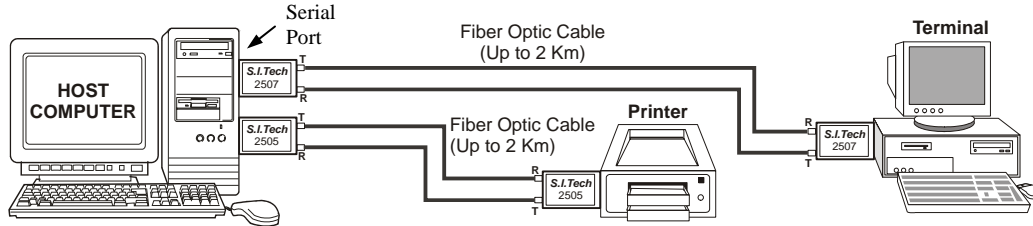

### 2. Multidrop:

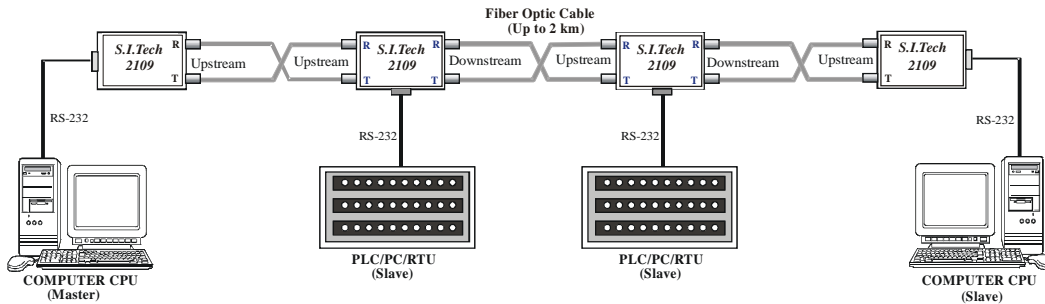

### 3. Remote Terminal Cluster Using Multiplexers:

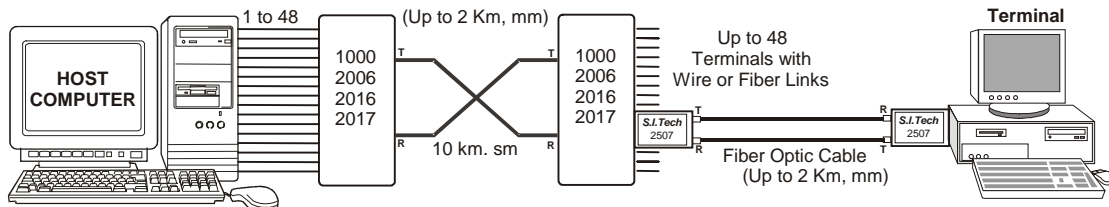

### 4. User Clusters:

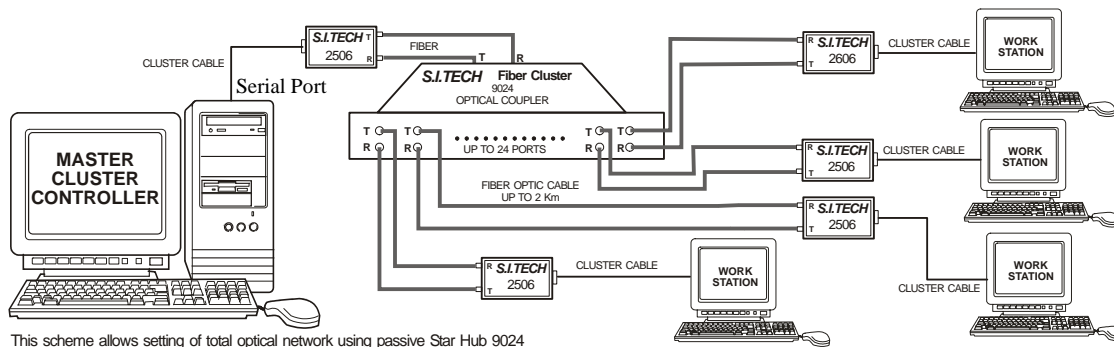



## 5. Ring (Loop)

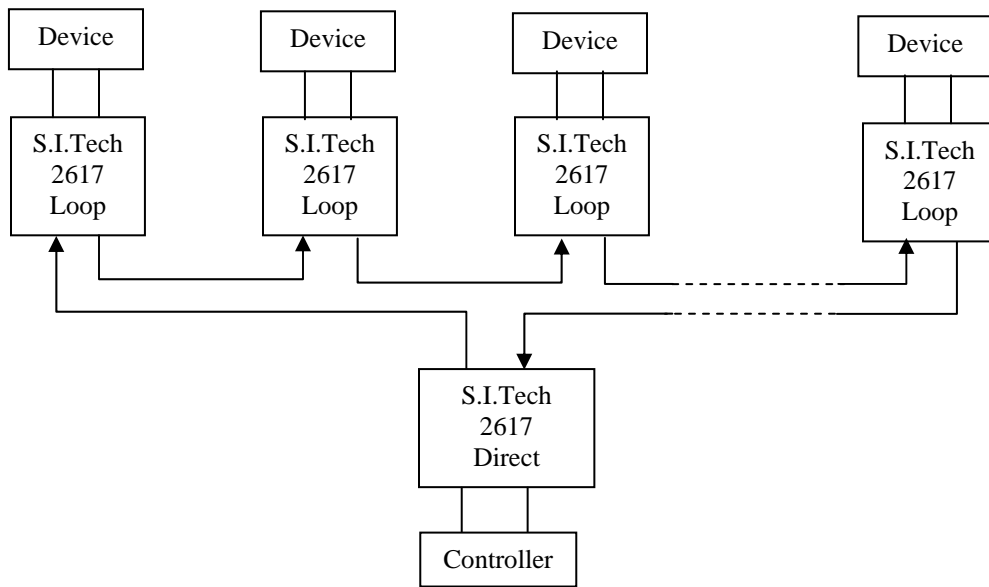

## 6. Opto Isolated

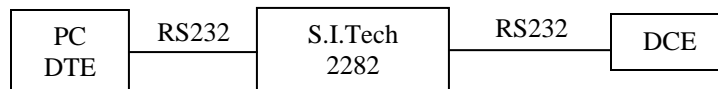

## RS-232

S.I. Tech's business and original developments started with RS-232 or so called serial communications. In early 1980, with the need for computerization of various processes, offices, and businesses there was an increasing use of the serial port. It was apparent that longer distance communications was not possible as wire and cables of the day were very limited in data communication capabilities.

Belden and subsequently S.I.Tech were first to develop affordable fiber optic data communications. The first products were tested and approved by Bell Labs, DEC, and others. S.I.Tech has continued this tradition of developing new and different applications of fiber optics technology. S.I.Tech also develops OEM oriented products for very specific applications such as Energy Management Systems, POS Systems, and Process Control.

While S.I.Tech has concentrated on data communications with recent trends of merging datacom and telecommunications, many LAN/WAN products combine these capabilities.

RS-232 SPECIFICATION: Electronic Industries Association (EIA) and American National Standards Institute (ANSI) have issued EIA-232 standard for "Interface between Data Terminal Equipment (such as a computer) and Data Circuit Terminating Equipment Employing Serial Binary Data Interchange".

This standard is also covered under International Standard such as CCITT V.24, V.28, and ISO IS 2110.

Comparisons of various RS-232 products available from S.I. Tech can be found on the following pages. Specific technical data sheets can be viewed from the S.I. Tech web site, <http://www.sitech-bitdriver.com>.

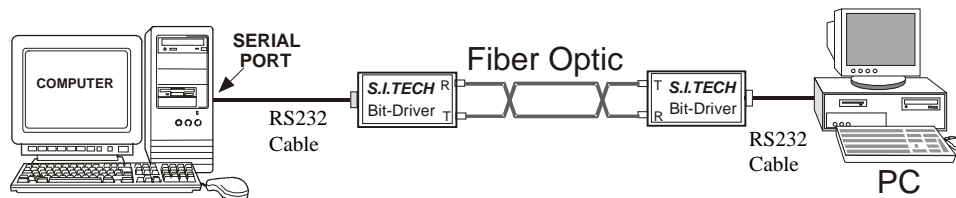

## RS-232 CONNECTOR

EIA-232 (formerly RS-232, which it is called by most of the industry and which it is called in S.I. Tech literature) is a standard for the interface between data terminal equipment (DTE) and data circuit terminating equipment (DCE), employing serial binary data exchange.

The standard calls for a specific 25-position connector that is called DB-25 in S.I. Tech literature. The standard also specifies that the female connector shall be part of the DCE. In general, S.I. Tech RS-232 Bit-Drivers® are DCE's and the connectors, as shown in Tables A, B, and C under "Data Connection" are DB-25F.

Contact numbering for DB-25F and DB-25M is shown in Figure 1. RS-232 assigns a function to each contact as shown in Table 1 but allows for non-standard pinouts for special applications. Individual data sheets for each S.I. Tech Bit-Driver product indicates the RS-232 pinouts for that product.

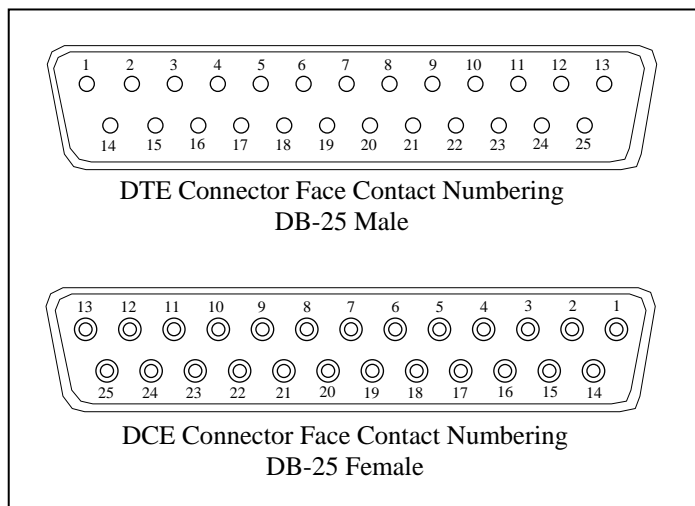

Figure 1. Contact Numbering for DB-25 M and DB-25 F

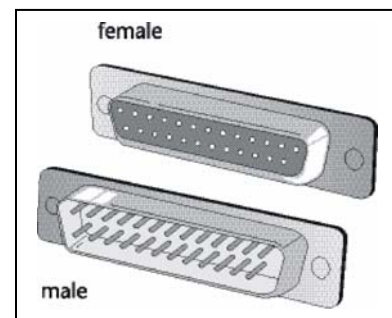

Figure 2. DB-25 F and DB-25 M Connector

Interchange circuits between DTE and DCE fall into four general categories:

- Ground or Common Return
- Data Circuits
- Control Circuits
- Timing Circuits

Strictly speaking, two-way data communication can be maintained using only 3 pins:

- Pin 2 - Transmitted Data
- Pin 3 - Received Data
- Pin 7 - Signal Ground

Everything else depends on the requirements of the DTE. For example, if the terminal needs to transmit a "request to send" and receive a "clear to send" before it can send data, some Bit-Drivers connect pin 4 directly to pin 5, while others include a delay circuit between 4 and 5.

It must be remembered that most DTE are configured to communicate with each other using modems (modulators-demodulators) so that telephone lines can be employed, and that the modems include circuitry directing the output from pin 2 of the near DTE to pin 3 of the far DTE and vice-versa so that you don't have two "transmit" circuits trying to talk to each other. If two DTE are adjacent, a "null modem" cable having DB-25F connectors at both ends and the proper pinout changes to permit communication as if modems were present, can be used.

S.I. Tech Bit-Drivers are intended to replace modems and telephone cable with fiber optic cable (or in some cases dedicated copper cable) and they perform the cross-connection functions of a modem. Simply unplug the DTE RS-232 cable from the modem and plug it into the Bit-Driver at each end of the circuit.

TABLE 1  
PIN NUMBER ASSIGNMENTS FROM RS-232-C  
DB-25 CONNECTOR

DB9 Pin No.	DB25 Pin No.	DESCRIPTION AND ABBREVIATION	TYPICAL BIT-DRIVER® PINOUTS	
			ASYNCHRONOUS	SYNCHRONOUS
	1	Protective Ground	X	X
3	2	Transmitted Data TD	X	X
2	3	Received Data RD	X	X
7	4	Request To Send RTS	X	X
8	5	Clear To Send CTS	X	X
6	6	Data Set Ready DSR	X	X
5	7	Signal Ground G	X	X
1	8	Received Line Signal Detector DCD	X	X
	9	Reserved for Testing or Host-Powered Positive Voltage 12VDC	Mini	Mini
	10	Reserved For Testing		
	11	Unassigned		
	12	Secondary Received Line Signal Detector		
	13	Secondary Clear To Send		
	14	Secondary Transmitted Data		
	15	Transmitter Signal Element Timing (DCE Source)		X
	16	Secondary Received Data		
	17	Receiver Signal Element Timing (DCE Source)		X
	18	Unassigned		
	19	Secondary Request To Send		
4	20	Data Terminal Ready DTR	X	X
	21	Signal Quality Detector		
9	22	Ring Indicator		
	23	Data Signal Rate Selector (DTE/DCE Source)		
	24	Transmitter Signal Element Timing (DTE Source)		X
	25	Unassigned		

**NOTES:**

1. EIA-232-D changes Pin 1 Description to "shield" and adds certain test functions which are not implemented in S.I. Tech RS-232 Bit-Drivers®.
2. These are Typical – See Individual Data Sheets for Exact Information

## TABLE A RS-232 TO FIBER BIT-DRIVERS® (MODEMS)

Model No.	Package		Data Format		Fiber Connection (Multimode)	Point to Point	Distance *** km	Multimode *** System Wavelength (SM-1300nm) nm	Weight LB/KG	Single Mode Connector *****	Remarks
	Stand Alone	Rack Mount	Async	Sync							
2004	✓		✓		DB-25 F	✓	2	880	3/1.4	ST/FC	Sync Modem
2005	✓		✓		DB-25 F	✓	5	880	3/1.4	ST/FC	Async Plus Diagnostics
2036	✓		✓		DB-25 F	✓	10	820	3/1.4	ST/FC	High Speed RS-232
2109	✓		✓		DB-25 F	✓	10	820	0.25/0.1	ST/FC	Async - Fiber In/Out, RS-232 Drop
2139	✓		✓		SMA/ST/ST	✓	20	660/820	0.25/0.1	ST/FC	Async - Fiber on all side
2282	✓		✓		DB-9 F/M	✓	-	-	0.6/0.3	-	Opto Isolated RS232 to RS232 ITU V.28
2304		✓	✓		DB-25 F	✓	✓	880	0.5/0.2	ST	Sync Card Version 2004
2305		✓	✓		DB-25 F	✓	✓	880	0.5/0.2	ST	Async Card Version 2005
2360		✓	✓		DB-25 F	✓	✓	820	0.5/0.2	ST/FC	2560 Card Version
2503		✓	✓		DB-25 M	✓	✓	820	0.25/0.1	-	Async/Sync Plus Control
2505		✓	✓		DB-25 M/F/9	✓	✓	880	0.25/0.1	-	Async Mini
2506		✓	✓		DB-25 M/F	✓	✓	820	0.25/0.1	-	Async Plus Controls
2507		✓	✓		Host	✓	✓	820	0.25/0.1	-	Host Power
2512		✓	✓		DB-25 M/F	✓	✓	880	0.25/0.1	-	2506 Mark and Space Reversed*****
2515		✓	✓		DB-25 M/F/9	✓	✓	880	0.25/0.1	-	2505 Mark and Space Reversed*****
2517		✓	✓		Host	✓	✓	820	0.25/0.1	-	2507 Mark and Space Reversed*****
2557		✓	✓		DB-25 M	✓	✓	820	0.25/0.1	-	2505 +5v Power
2560	✓		✓		DB-25 F	✓	✓	820	0.9/0.4	ST/FC	Async - Ruggedized, IEEE/IEC
2563		✓	✓		DB-25 F	✓	✓	820	0.4/0.2	ST/FC	Async - RS232/422/485
2607		✓	✓		DB-25 F	✓	✓	820	0.25/0.1	ST/FC	Async - Extended Temp
2617		✓	✓		DB-9 F	✓	Loop	820	0.6/0.3	ST/FC	Async - Ruggedized, Ext Temp, Loop
2834		✓	✓		DB-25 S	✓	✓	820	6/2.7	ST/FC	1 RS232 + 1 ET Channel, 1U Rack
3503		✓	✓		DB-25 M	✓	✓	820	0.4/0.2	-	Async/Sync Plus Controls - Tempest
Kit #1											Mint Kit (2505)
Kit #8											Vulcan RS232 (2005) Kit
Kit#17											2560 SM(1310)&2560 SM(1550) WDM Kit

\* Power Options: See Power Options and How to Order p. 106

\*\* Pin outs are specified in RS-232 pin out chart and data sheets  
Temperature range 0 - 50 degrees C unless shown otherwise.

Extended Temperature (ET) range available on some products.

\*\*\* Distance: 2 km - STD, 5 km - L, 10 km - XL, 20 km - UL.

\*\*\*\* Use one wavelength throughout system

\*\*\*\*\* Only Models having fiber connector entry in this column are available in **single mode**

\*\*\*\*\* Example:

2505 TR LED is ON in Mark Condition

2515 TR LED is OFF in Mark Condition

This feature is transparent to the DTEs but is desired by some users to be compatible with other manufacturers' products.

### HOW TO ORDER

Base Model Number XXXX	Power* 110 VAC - STD 230 VAC - V 4, 5, 6, 7, 9 and 10 See attached chart	Data Connector** M or F (F is STD on most models.)	Distance*** 2 Km - STD Other - Specify L, XL, or UL	Fiber and Connector		Temperature 0 - 50°C - STD -40 to +80° C - ET Other - Call S.I. Tech
				Multimode (MM) - STD Other - Specify	Singlemode (SM) - Specify ST - STD Other - Specify	

e.g. 2005 = RS 232 to Fiber Bit-Driver, 110 VAC, DB25 Female, 2 Km, Multimode, ST Connectors, 0 - 50 °C

2005V-XL-SM-ST = RS-232 to Fiber Bit-Driver, 230VAC, DB25 Female, 10 Km, Single Mode, ST Connectors, 0 - 50 °C

Specifications subjected to change without notice

## RS-232 TO FIBER OPTIC BIT-DRIVERS®

2004



- ❑ Synchronous Simplex or Full Duplex Optical Bit-Driver®
- ❑ Switchable Internal Clock Rates 2.4 Kbps to 19.2 Kbps
- ❑ External Clocking for up to 56 Kbps
- ❑ Digital and Analog Loop-Back Tests
- ❑ Diagnostic Logic Probe built in

2005



- ❑ Most Versatile RS-232 to Optical Asynchronous Bit-Driver®
- ❑ DTE/DCE Switch built in
- ❑ Diagnostic Logic Probe built in
- ❑ Multimode or Single mode fiber options
- ❑ Installed in Applications Worldwide
- ❑ Use with 212005 to convert to USB

2036



- ❑ Synchronous/Asynchronous Full Duplex Optical Bit-Driver®
- ❑ Switch-Selectable Synchronous Data Rates 9.6 Kbps to 64 Kbps
- ❑ Asynchronous Mode from 2.4 Kbps to 64 Kbps
- ❑ Switch Selectable Digital and Analog Loopback Test Capability built in

2109



- ❑ Mini Asynchronous Half Duplex Optical Bit-Driver®
- ❑ Max Data Rate 19.2 Kbps
- ❑ Supports SCADA, PLC and other Multidrop Optical Networks
- ❑ Fiber ports repeat data through the 2109 and drop/insert data on the RS-232 port
- ❑ RS-232 Port only inserts data onto and gets data dropped from the upstream Fiber Port
- ❑ Downstream Fiber Port only sends/receives data from upstream Fiber Port

2139\*



- ❑ RS-232 Multidrop with Fibers on all 3 sides
- ❑ Max Data Rate 19.2 Kbps
- ❑ Isolates and Protects SCADA equipment
- ❑ Allows Longer Length Drops Compared to wired RS-232
- ❑ Can be Combination of Multimode/Single mode/Plastic Fiber

2282\*



- ❑ RS-232 to RS-232, DB9 Male to DB9 Female
- ❑ Up to 115 Kbps Data Rate
- ❑ Meets EIA RS-232F and ITU V2.8
- ❑ Opto Isolated Design to Protect Attached Equipment
- ❑ 12 VDC Power
- ❑ Miniature Size

**2304**

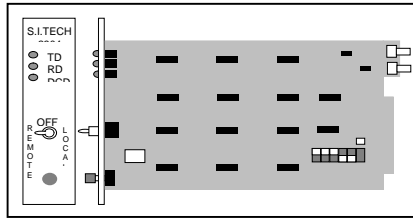

- ❑ Card Cage Mounted Synchronous Simplex or Full Duplex Optical Bit-Driver®
- ❑ Up to 16 Cards will fit S.I. Tech Model 3000B, 19 inch Rack
- ❑ Available on American Standard size Card
- ❑ Designed for use with S.I. Tech Model 2004 Standalone Bit-Driver

**2305**



- ❑ Card Cage Mounted Asynchronous Simplex or Full Duplex Optical Bit-Driver®
- ❑ 2305 A on Eurocard fits S.I. Tech Model 3000A, 19 inch Rack
- ❑ 2305 B on American Standard Card fits S.I. Tech Model 3000B, 19 inch Rack
- ❑ Up to 16 Cards will fit 19 inch Rack
- ❑ Designed for use with S.I. Tech Model 2005/2505 or other Asynchronous Standalone or Mini Bit-Drivers

**2360\***



- ❑ Card Version of S.I. Tech #2560 RS-232 Ruggedized Modem
- ❑ Eurocard Size, Async Product
- ❑ Rack holds 12 Cards with 2 Power Supplies
- ❑ Ideal for Central Control Room

**2503**

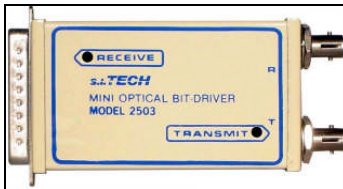

- ❑ Mini Asynchronous/Synchronous Full Duplex Optical Bit-Driver®
- ❑ Switch Selectable Synchronous Data Rates 1.2 Kbps to 9.6 Kbps Asynchronous to 19.2 Kbps
- ❑ Provides for Control Signals (Handshake Lines)
- ❑ Recommended for such Applications as ATM Machines
- ❑ Designed to work with S.I. Tech 3503 TEMPEST Bit-Driver
- ❑ Male RS-232 DB-25 connector is standard

**2505**

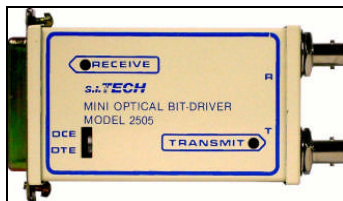

- ❑ Mini Asynchronous Simplex or Full Duplex Optical Bit-Driver®
- ❑ Speeds up to 115 Kbps
- ❑ Low Cost – Most Popular Unit for Multimode Fiber Applications
- ❑ Switch Selectable as DTE or DCE. Optionally available with male RS-232 DB-25 connector as 2505 M, with DB9 as 2505 MOD.
- ❑ Powered Directly thru Pin 9 or Externally with S.I. Tech Model 2121/2164 Power Supply
- ❑ Available with Mark and Space Reversed as Model 2515

**2506**

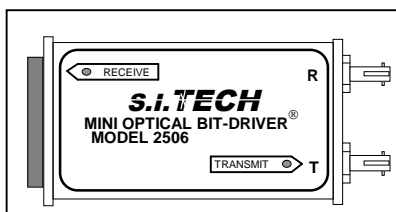

- ❑ Mini Asynchronous Simplex or Full Duplex Optical Bit-Driver®
- ❑ Implements Full Duplex Control (Handshake) Signals
- ❑ Up to 56 Kbps Asynchronous Data Rate
- ❑ Powered Directly through Pin 9 or externally with S.I. Tech Model 2121/2164 Power Supply
- ❑ Optionally Available with Male RS-232 DB-25 Connectors as 2506M and as Female 2506F

2507



- ❑ Mini Asynchronous Simplex or Full Duplex Optical Bit-Driver®
- ❑ Powered only from Host Computer
- ❑ Up to 19.2 Kbps Asynchronous Data Rate
- ❑ Switch Selectable as DTE or DCE. Optionally Available with Male RS-232 DB-25 Connector as 2507M
- ❑ Standard Max Operating Distance 2.0Km. Optional Plastic Fiber version is 100 meters max (660nm) #2507-660
- ❑ Available with Mark and Space Reversed as Model 2517

2557

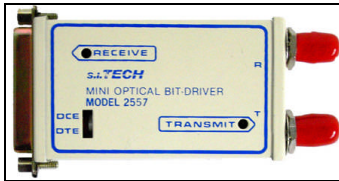

- ❑ Mini Asynchronous Simplex or Full Duplex Optical Bit-Driver®
- ❑ Up to 115 Kbps Asynchronous Data Rate
- ❑ Intended for use with Process Controller or Computer which supplies +5VDC on Pin 9
- ❑ Switch Selectable as DTE or DCE. Standard Model has RS-232 DB-25M Male Connector but RS-232 DB-25F Female Connector is Optional
- ❑ 1000 Ft (300m) Distance Capability

2560\*



- ❑ RS232 Asynchronous to Fiber Optic Bit Driver
- ❑ Up to 115.2 Kbps, 2 Control Signals
- ❑ Conformal Coated - Environmental Protection
- ❑ Extended Temp. Range -40 to +80 °C
- ❑ Complies with IEEE C37-90-1
- ❑ IEC 801 Surge Protection
- ❑ Rugged Enclosure with Panel Mounting Brackets
- ❑ Various AC/DC Power Options

2563\*



- ❑ Three in one design RS-232/422/485 to Fiber
- ❑ Max 115.2 Kbps Data Rate
- ❑ Switch for RS-485 Speed Setting
- ❑ Din Rail Option
- ❑ Multimode or Single mode

2607\*



- ❑ Mini RS-232 Bit Driver, Async Fiber optic, 115 Kbps
- ❑ Extended Temp. Range -40 to +65 °C
- ❑ 9 to 32 VDC Input Power
- ❑ Multimode or Single mode

2617

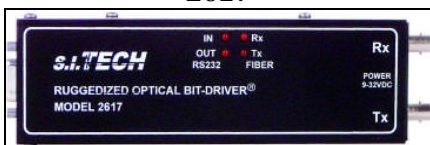

- ❑ Mini RS-232 Bit Driver, Async, 57.6 Kbps
- ❑ Extended Temp. Range -40 to +85 °C
- ❑ Direct (Point to Point) or Loop (Ring) mode
- ❑ Rugged enclosure
- ❑ Various AC/DC power options



## 2834\*

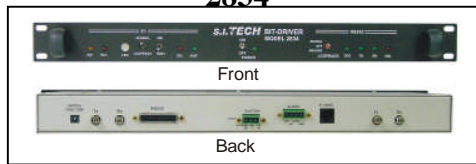

- ❑ 1 - RS232 Channel and 1 - E1 (or T-1) Channel
- ❑ 1U - 19" Rack Mounted
- ❑ Multimode or Single mode
- ❑ RS232 Async or Sync and Various Speed Options

## 3503



- ❑ Mini Synchronous/Asynchronous Full Duplex Optical Bit-Driver®
- ❑ Designed to Meet TEMPEST Specifications
- ❑ Connector is RS-232 DB-25M Male
- ❑ Switch Selectable Synchronous Data Rates up to 9.6 Kbps
- ❑ Asynchronous Data Rates to 19.2 Kbps
- ❑ Provides Control (Handshake) Signals
- ❑ 6600 Ft (2Km) Max Distance Capability
- ❑ SMA or ST Connectors

## KIT #1\*



- ❑ 2 S.I.Tech 2505 DB-9 Multimode, ST
- ❑ 2 S.I.Tech 2121 Power Supply
- ❑ 1 S.I.Tech 5202-010-8235 (33 ft.) FO Cable Assembly
- ❑ Plug and Play

## KIT #8\*



- ❑ Vulcan RS-232 Kit
- ❑ 2 S.I.Tech #2005 Multimode ST Bit Driver
- ❑ 1 S.I.Tech #7202-0200-8255 FO Ruggedized Cable Assembly (200 ft.), ST/ST
- ❑ 1-7096, 1-7092 Data Cable Assembly
- ❑ Plug and Play for Vulcan (Plasma Cutting Machine)

## KIT #17\*



- ❑ 10 Km Ruggedized Link
- ❑ 1 S.I.Tech 2560 (1310 nm)
- ❑ 1 S.I.Tech 2560 (1550 nm)
- ❑ 2 WDM S.I.Tech #1315
- ❑ 2 S.I.Tech #8077 ST/ST Couplers
- ❑ 2 DB25 RS-232 Cable Assemblies

## TABLE B RS-232 METALLIC BIT-DRIVERS® (SHORT HAUL MODEMS)

Model No.	Package		Max. Data Rate Kbps	Data Format		Power Option*	Data Connector**	Point to Point	Multidrop	Distance Km ***		Weight LB/KG	Remarks
	Stand Alone	Rack Mount		Mini Card	Async					For Max. Data Rate	See Curves For Data Rate		
2025	√		56	√	Async	1,2	DB-25 F	√	√	2	5	3/1.4	RS-232 to RS-422 Async
2282		√	115	√		6	DB9F/DB9M	√		-	-	0.6/0.3	RS-232 to RS-232 Opto Isolated
2526		√	19.2	√		5	DB-25 M/F	√		√	√	0.25/0.1	RS-232 to RS-422 Async
2527		√	19.2	√		Host	DB-25 M/F	√		√	√	0.25/0.1	RS-232 to RS-422 Async
9338	√		56	√		1,2	DB-25 F	√		√	√	2.2/1	RS-232 to RS-422 Async, Plastic Case
212005		√	256	√		-	DB-25/USB	√	-	-	-	0.25/0.1	RS-232 to USB

\* Power Options: See "Power Options and How to Order" sheet (p. 106) for options and ordering instructions.

\*\* Pin outs are specified in RS-232 pin out chart and data sheets  
Temperature range 0 - 50 degrees C unless shown otherwise.  
Extended Temperature (ET) range available on some products.

\*\*\* Distance Chart

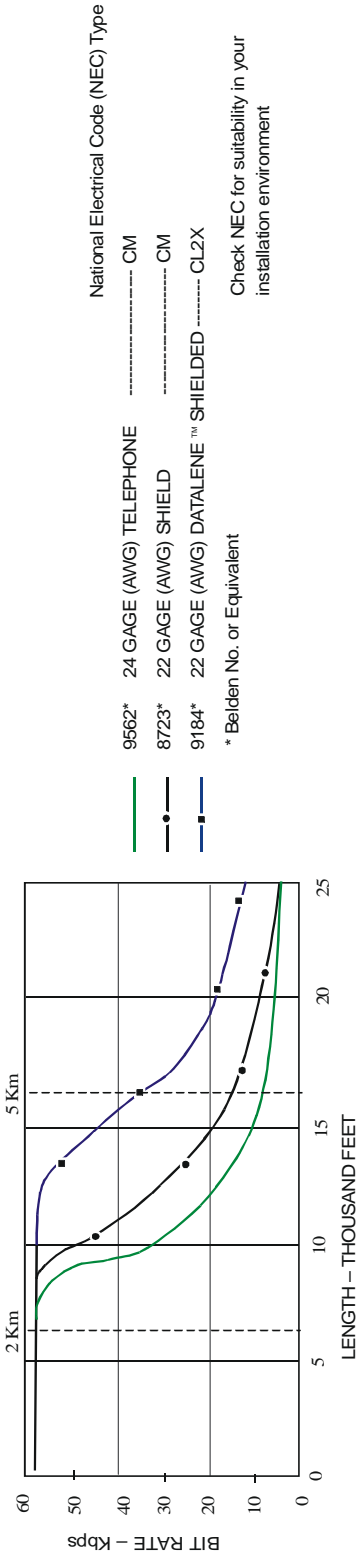

### HOW TO ORDER

Base Model Number	Power*	Data Connector**	Temperature
XXXX	110 VAC - STD 230 VAC - V 5. See attached chart	M or F (F is STD on all models)	0 - 50° C - STD Other - Call S.I.Tech

e.g. 9338 = 9338, 110 VAC, DB25 Female, 0 - 50°  
2526M = 2526, (Requires S.I.Tech #2101 Power Supply) DB25 Male, 0 - 50° C

Specifications subject to change without notice.

## RS-232 METALLIC BIT-DRIVERS®

### 2025

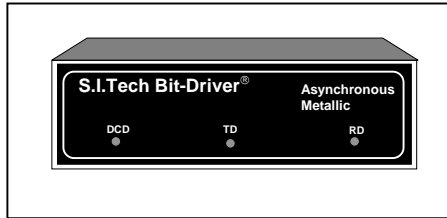

- ❑ Most versatile RS-232 to Metallic (RS-422) Asynchronous Simplex or Full Duplex, Stand Alone (Short Haul Modem) Bit-Driver®
- ❑ Data Rates up to 56 Kbps
- ❑ Transmission Lines protected at 8 volts up to 50 Amp Pulses
- ❑ Internal Diagnostic Logic Probe
- ❑ Internally switchable DTE/DCE
- ❑ Multidrop version available as 2025-MD

### 2526

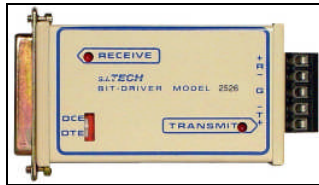

- ❑ Mini Asynchronous RS-232 to Metallic (RS-422) Simplex or Full Duplex Bit-Driver® (Short Haul Modem)
- ❑ Data rates up to 19.2 Kbps
- ❑ Externally Switch Selectable DTE or DCE operation
- ❑ Powered by +12V DC on Pin 9 of DTE or by External 12 VDC Power Supply – S.I. Tech Model #2101 (110 VAC) or #2102 (230 VAC)
- ❑ Male or Female RS-232 DB-25 Connectors available

### 2527



- ❑ Mini Asynchronous RS-232 to Metallic (RS-422) Simplex or Full Duplex Bit-Driver® (Short Haul Modem)
- ❑ Same details as S.I. Tech Model 2526 except power must come from Data Pins of DTE. No provision for External Power Supply

### 212005\*

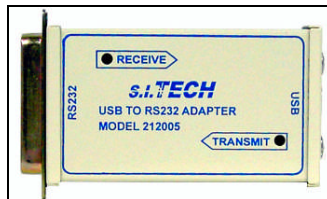

- ❑ USB to RS-232 Bit-Driver
- ❑ Use to Convert any RS-232 Bit Driver to USB
- ❑ Plugs into DB25F Pin Connector or optional DB9F Connector
- ❑ Powered from USB Host
- ❑ Data Rates to 250 Kbps
- ❑ Virtual COM port drivers provided

### 9338



- ❑ Basic RS-232 to Metallic (RS-422) Asynchronous Simplex or Full Duplex Stand Alone Bit-Driver® (Short Haul Modem).
- ❑ Data Rates up to 56 Kbps
- ❑ Transmission Lines protected at 8 Volts up to 50 AMP Pulses
- ❑ Transmission Line DC Resistance limited to 150 ohms maximum one-way
- ❑ Attached Power Supply Cord for 110 VAC. 230 VAC model is available as 9338V.

## 2282



- ❑ Opto Isolated RS-232 to RS-232 DB9 Male to DB9 Female
- ❑ 12 VDC or VAC Power
- ❑ Miniature Size
- ❑ Up to 115 Kbps data Speed
- ❑ Meets EIA RS-232F and ITU V.28
- ❑ 1000 VAC Isolation

## TABLE C RS-232 TO FIBER OPTIC MULTIPLEXERS

Model No.	Package		Max. Data Rate Kbps	Data Format			Power Option*	Data Connector**	Number of Channels	Point to Point	Distance *** Km				Weight LB/KG	Multimode (820 nm)/ Singlemode (1300 nm)	Trunk**** Fiber Connector	Remarks
	Stand Alone	Rack Mount		Async	Sync	Control Signals					2	5	10	20				
1000	✓	✓	19.2	✓	✓	✓	1,2	DB-37/FO	48	✓	✓	✓	✓	✓	MM/SM	ST/SMA	Tempest Option - Fiber In/Fiber Out	
2006	✓	✓	19.2	✓	✓	✓	1,2	DB-25 F	8	✓	✓	✓	✓	✓	MM/SM	ST/SMA	8 CH Async/Sync	
2007	✓	✓	19.2	✓	✓	✓	1,2	DB-25 F	8	✓	✓	✓	✓	✓	MM	ST/SMA	6 CMOS, 2 RS-232, Tempest Case	
2016	✓	✓	19.2	✓	✓	✓	1,2	DB-25 F	16	✓	✓	✓	✓	✓	MM/SM	ST/SMA	16 CH Async	
2016-O	✓	✓	19.2	✓	✓	✓	1,2	SMA/ST	16	✓	✓	✓	✓	✓	MM/SM	ST/SMA	16 CH Async. Optical to Optical	
2017	✓	✓	76.8	✓	✓	✓	1,2	DB-32 F	4	✓	✓	✓	✓	✓	MM/SM	ST/SMA	Requires 7017 Cable	
2216	✓	✓	19.2	✓	✓	✓	1,2	DB-25 F	16	✓	✓	✓	✓	✓	MM/SM	ST/SMA	2 - 8 Bit Words Parallel	

\* Power Options: See "Power Options and How to Order" sheet (p. 106) for options and ordering instructions.  
 \*\* Pin outs are specified in RS-232 pin out chart and data sheets  
 \*\*\* Distance: 2 km - STD, 5 km - L, 10 km - XL, 20 km - UL.  
 \*\*\*\* Other connector options for singlemode is FC.  
 Temperature range 0 - 50 degrees C unless shown otherwise.

### HOW TO ORDER

Base Model Number XXXX	Power Option* 1. 110 VAC - STD 2. 230 VAC - V	Data Connector** F (F is STD on all models.)	Distance*** 2 Km - STD Other Specify L, XL or UL	Fiber Connector		Temperature 0 - 50° C - STD Other - Call S.I.Tech
				Multimode (MM)-STD ST - STD Other - Specify	Singlemode (SM)-Specify ST - STD Other - Specify	

e.g. 2006A = RS-232 Async, 8 CH to Fiber Multiplexer, 110 VAC, DB25 F, 2 Km, Multimode ST, 0 - 50 ° C  
 2006A-V-XL-SM-ST = RS-232 Async 8 CH to Fiber Multiplexer, 230 VAC, DB25 F, 10 Km, Single Mode, ST, 0 - 50 ° C

Specifications subject to change without notice.

## RS-232 TO FIBER OPTIC MULTIPLEXERS

### 1000

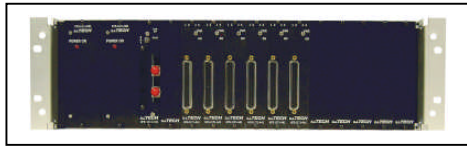

- ❑ Flexible Rack Mounted Time Division Multiplexer Bit-Driver® using Eurocard size cards for desired function
- ❑ Up to 48 Full Duplex Channels, Drop and Insert Capability
- ❑ Backbone Data Rate is 10 Mbps
- ❑ TEMPEST version with Fiber in/out available
- ❑ See Series 1000 Data Sheet for card information

### 2006



- ❑ Eight Channel Asynchronous/Synchronous Simplex or Full Duplex Time Division Multiplexer Optical Bit-Driver®
- ❑ Each Channel independently switchable internally for 0 to 19.2 Kbps Asynchronous or 1.2 Kbps through 19.2 Kbps (5 rates) Synchronous.
- ❑ Aggregate Speed is 160 Kbps
- ❑ Optional Metal Enclosure with ears for mounting in standard 19 inch Rack
- ❑ Detachable Power Supply Cord, 110 or 230VAC Power Input
- ❑ Digital/Analog Loopback Test available for each channel independently

### 2007

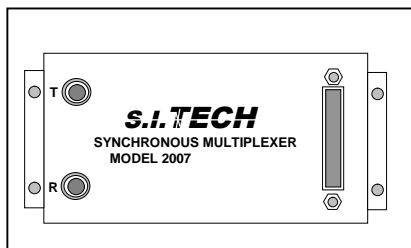

- ❑ Eight Channel Synchronous Simplex or Full Duplex Time Division Multiplexer Optical Bit-Driver®
- ❑ Two Channels have +/- 12V Swing RS-232 Interfaces
- ❑ Six Channels have 0-5V Swing CMOS Interfaces with Pull-up to +5V on each Input
- ❑ Max Data Rate is 19.2 Kbps
- ❑ Input Power ± 15V DC @ 250mA via RS-232 DB-25 F Connector

### 2016



- ❑ Sixteen Channel Asynchronous Simplex or Full Duplex Time Division Multiplexer Optical Bit-Driver®
- ❑ Max Data Rate is 19.2 Kbps
- ❑ Digital/Analog Loopback Test available for each channel independently
- ❑ Optional Input/Output Interface for RS-422, TTL, 20mA
- ❑ Optional Metal Enclosure with ears for mounting in standard 19 inch Rack
- ❑ 110 or 230VAC Input Power, Detachable Power Card

### 2016 – O

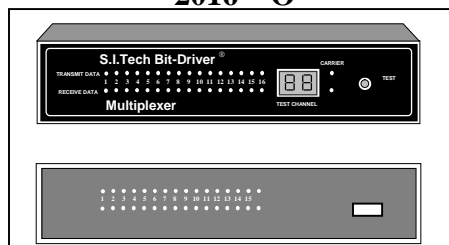

- ❑ Sixteen Channel Asynchronous Simplex or Full Duplex Time Division Multiplexer Optical Bit-Driver®
- ❑ Max Data Rate is 19.2 Kbps
- ❑ Digital or Analog Loopback Test available for each channel
- ❑ Input/Output Interface Optional SMA or ST Connectors
- ❑ Rack Mounting Option
- ❑ 110 or 230 VAC Power, Detachable Power Cord

## 2017



- ❑ Four Channel Asynchronous Simplex or Full Duplex Time Division Multiplexer Optical Bit-Driver®
- ❑ Each Channel provides Full Duplex Data up to 19.2 Kbps
- ❑ Two Units can be mounted side by side in standard 19 inch Rack
- ❑ Each Unit requires one S.I. Tech #7017 "4-to-1" Cable
- ❑ 110 or 230VAC Input Power, Detachable Power Card

## 2216

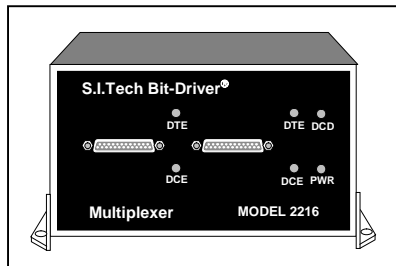

- ❑ Sixteen Channel Asynchronous Simplex or Full Duplex Time Division Multiplexer Optical Bit-Driver®
- ❑ Intended to move two eight-bit Parallel Words (one per RS-232 DB-25F Cable from DTE, two required).
- ❑ Data Rate is 19.2 Kbps per Channel, 320 Kbps Aggregate
- ❑ Built-in DCE/DTE jumpers
- ❑ Powered through 110 or 230VAC Line Cord

## RS-232 MODEM SPLITTER

9703\*



- Modem Sharing for 3 Users
- Inexpensive, Non Powered, Easy to Use
- Works Equally well in Sync or Async Mode
- Transparent to Speed and Protocol

9706\*



- Modem Sharing for 6 Users
- Inexpensive, Non Powered, Easy to Use
- Works Equally well in Sync or Async Mode
- Transparent to Speed and Protocol

9718\*

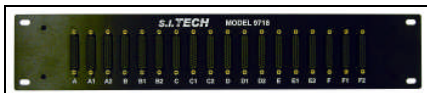

- Passive Splitter
- Connect 1 Server to 2 Backup Servers, Storage Networks
- 1 PC 2 Terminal Users
- Inexpensive, Non Power, Easy to Use
- Works Equally well in Sync or Async Mode
- Transparent to Speed and Protocol
- Designed for 1 to 6 Splitters up to 18 Users or Servers



**RS-422 PRODUCTS**

## RS-422 PRODUCTS

### 1. Point to Point:

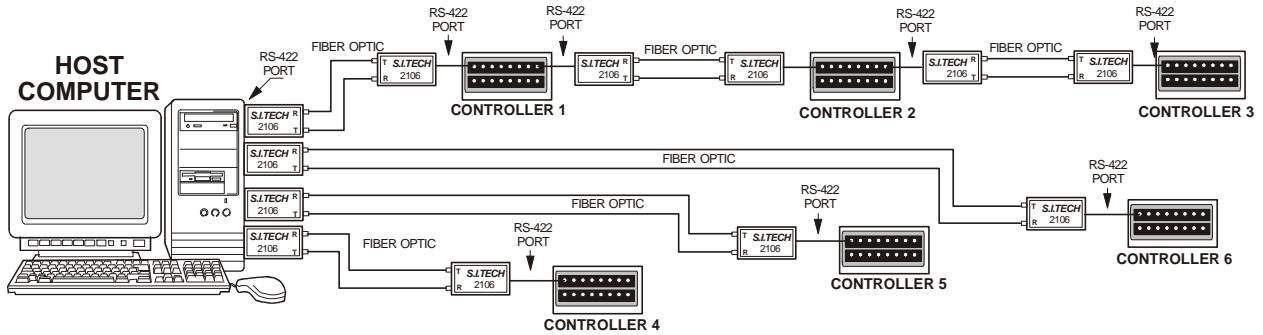

### 2. Multiplexer:

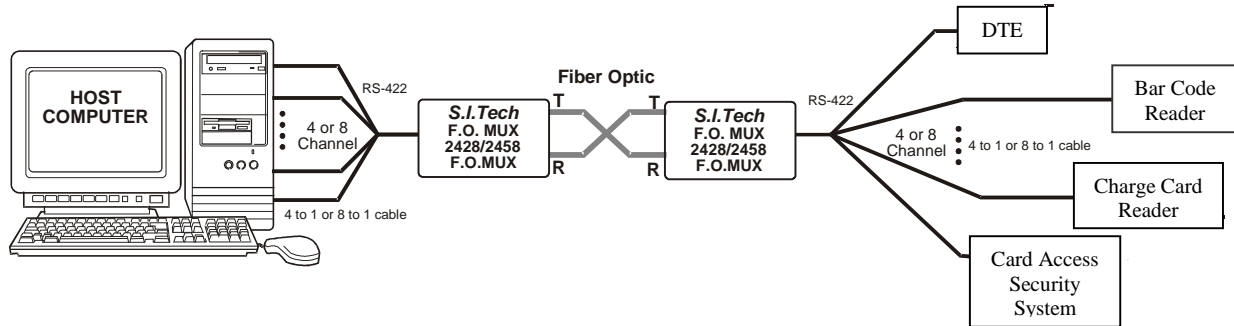

### 3. Protocol Conversion:

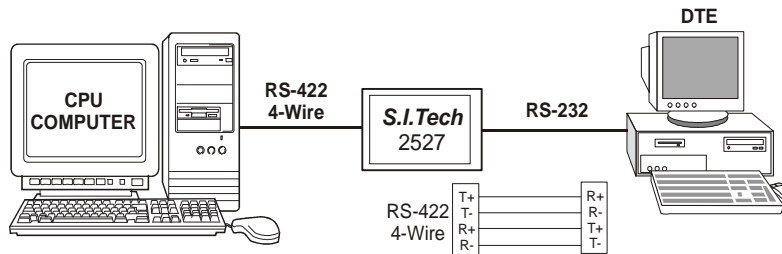

### 4. Opto Isolated:

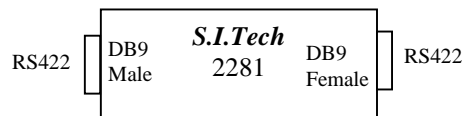

## RS-422

EIA-RS-422 is a widely used specification for balanced 4-wire transmission (twisted or 2 twisted shielded pairs) where there is a signal transmit pair and a signal receive pair. Balanced transmission allows much longer distances and reduces the number of data errors.

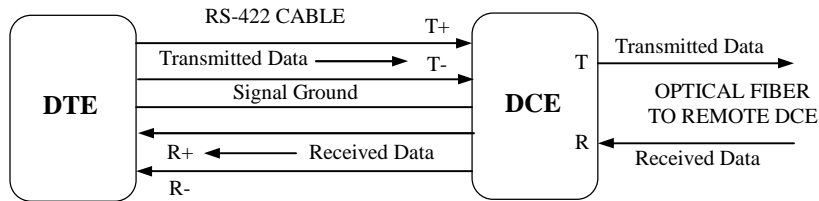

Typical Setup

S.I.Tech supplies a broad array of products using RS-422 protocol for various applications such as process control, security systems, T-Net, etc..

EIA-422 Standard specifies the electrical characteristics of the balanced voltage digital interface circuit, normally implemented in integrated circuit technology that may be employed when specified for the interchange of serial binary signals between Data Terminal Equipment (DTE) and Data Circuit – Terminating Equipment (DCE) or in any point-to-point interconnection of serial binary signals between digital equipment.

The provisions of EIA-422 may be applied to the circuits employed at the interface between equipment where the information being conveyed is in the form of binary signals at the DC baseband level. This Standard shall be referenced by the specifications and specific interface standards applying these electrical characteristics.

EIA-422 is one of the series relating to the interconnection of DTE and DCE. Other EIA Standards in this series include RS-423-A and RS-449. RS-423 is applicable to unbalanced Interface Circuits and RS-449 is comprehensive Standard covering RS-422 plus flow control and timing circuits. EIA-422 is fully compatible with CCITT recommendations V.11 and X.27.

## RS-422 CONNECTOR

Unlike RS-232, which is a standard for the interface between data terminal equipment and data terminating equipment, including connector dimensions and pin number assignments, RS-422 and RS-485 are standards for the electrical characteristics of balanced digital systems. They specifically do not cover such details as pin assignments.

Over the years, individual manufacturers of equipment having electrical characteristics conforming to RS-422 or RS-485 have selected electrical connections ranging from twisted pig-tails through screw terminals, various type D connectors and modular RJ-XX telephone-type plugs and jacks.

S.I. Tech products made for use in RS-422 or RS-485 systems employ all of the above connection methods to comply with standards set by individual manufacturers. Some of these are shown in the sketches below.

Please check the appropriate tables or individual data sheets to determine which data connection methods are available on the product you are considering and to get pin-out information.

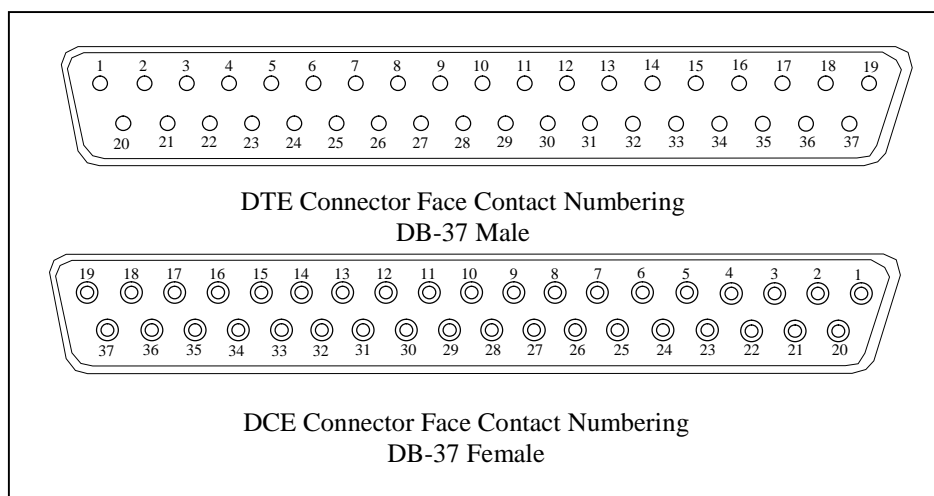
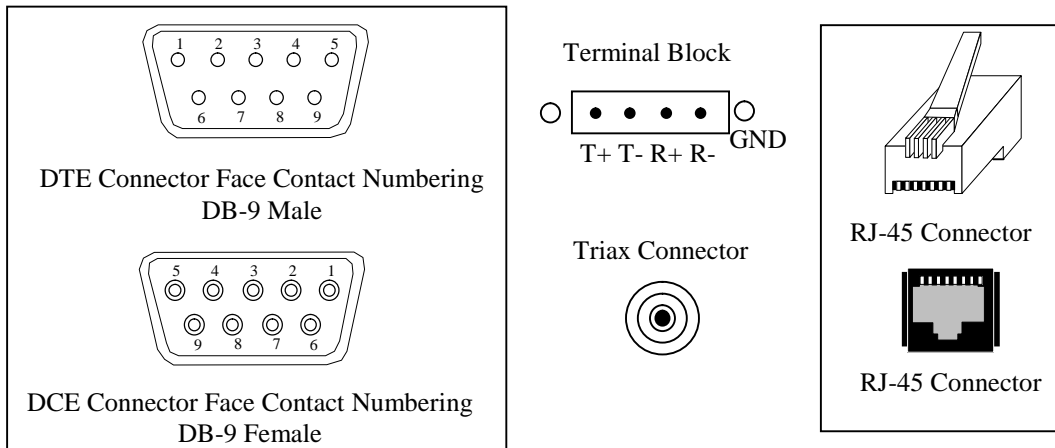

## TABLE D RS-422 TO FIBER BIT-DRIVERS® (MODEM)

Model No.	Package		Max. Data Rate Kbps	Data Format		4 Wire Data Connector**	Multimode Fiber		Singlemode Fiber Connector ***** 1300 nm	Point to Point	Multi-Drop	Distance *** Km			Weight LB/KG	Remarks
	PCB Stand Alone	Rack Mount Card		Async	Sync		Connector	Wavelength ****				2	5	10		
2012	✓		56	✓		Terminal Block	ST/SMA	880	---	✓		✓	✓	✓	3/1.4	Wall Mount
2106		✓	56	✓		DB-9M/F	ST/SMA	880	---	✓		✓	✓	✓	.25/1	Mini, 4 Wire RS-422
2116		✓	38.4		✓	DB-9M/F	ST/SMA	880	---	✓		✓	✓	✓	.25/1	Variable Speed, 4 Wire
2140		✓	230		✓	Terminal Block	ST/SMA	820	ST/FC	✓	✓	✓	✓	✓	-4/-2	Multidrop, ADD/Drop
2176		✓	256		✓	DB-9 F	ST/SMA	820	ST	✓	✓	✓	✓	✓	.25/1	High Speed, Mini
2281		✓	2.5M		✓	DB-9M/F	--	--	--	✓	✓	✓	✓	✓	0.8/0.3	Opto Isolated RS-422
2322		✓	56		✓	RJ45	ST/SMA	880	---	✓		✓	✓	✓	.5/2	Card - 3000 Chassis
2376		✓	256		✓	RJ45	ST/SMA	820	ST	✓		✓	✓	✓	.5/2	Card - 3000 Chassis
2561		✓	115		✓	1,2,3,10	ST/SMA	820	ST/FC	✓		✓	✓	✓	0.9/-4	Ruggedized RS-422
2563		✓	115		✓	DB-25	ST/SMA	820	ST/FC	✓		✓	✓	✓	0.4/0.2	Three in One RS232/422/485
2857		✓	10 M		✓	Terminal Block	ST/SMA	820	ST/FC/SC	✓		✓	✓	✓	3/1.4	High Speed RS-422
2859		✓	20M		✓	Triax Conn	ST/SMA	820	ST/FC	✓		✓	✓	✓	6/3	2 CH RS-422, 1U Rack
2880		✓	20M		✓	Triax BNC	ST/SMA	820	ST/FC	✓		✓	✓	✓	3-Jun	4 CH RS-422/TTL, 1U Rack
2886	✓		20M		✓	Terminal Block	ST/SMA	820	ST/FC	✓		✓	✓	✓	0.1/0.06	3" X 3" PCB (7.6 X 7.6 cm)
2887		✓	20M		✓	BNC & Term Blk	ST/SMA	820	ST/FC	✓		✓	✓	✓	6/3	3 CH Switchable RS-422 & TTL
212106		✓	256		✓	DB-9F/USB	--	--	--	✓		✓	✓	✓	0.25/0.1	RS-422 to USB
HFS 1172-132		✓	76.8		✓	DB-25 F	ST/SMA	820	---	✓		✓	✓	✓	.5/2	Card - 1000 Chassis
HFS 1176-192		✓	2 M		✓	Triax	ST/SMA	820	---	✓		✓	✓	✓	.5/2	Card - 1000 Chassis
575-0656-004		✓	10 M		✓	Triax	ST/SMA	820	---	✓		✓	✓	✓	.5/2	Card - 1000 Chassis 4 Ch Xmtr
575-0656-005		✓	10 M		✓	Triax	ST/SMA	820	---	✓		✓	✓	✓	.5/2	Card - 1000 Chassis 4 Ch Rcvr
Kit #9		✓	256		✓	DB-9 F	ST/SMA	820	---	✓		✓	✓	✓	-	POS Kit - Micros System

\* Power Options: See "Power Options and How to Order" sheet (p. 106) for options and ordering instructions.

\*\* Pin outs are specified in data sheets

Temperature range 0 - 50 degrees C unless shown otherwise. Extended Temperature (ET) range available on some products.

\*\*\* Distance: 2 km - STD, 5 km - L, 10 km - XL, 20 km - UL

\*\*\*\* Use one wavelength throughout system except if WDM is used

\*\*\*\*\* Only Models having fiber connector entry in this column are available in single mode

### HOW TO ORDER

Base Model	Data Connector**	Power*	Fiber and Connector		Temperature
			Multimode (MM)-STD	Singlemode (SM) -Specify	
XXXX	M or F (F is STD on most models)	2 Km - STD Other - Specify L, XL, or UL	ST-STD	ST-STD	0 - 50° C - STD -40 to +80° C - ET Other - Call S.I. Tech

e.g. 2012 = RS 422 to Fiber Bit-Driver, 110 VAC, Terminal Block, 2 Km, Multimode, ST Connectors, 0 - 50 ° C  
2106 = RS-422 to Fiber, Mini Bit-Driver, DB9F, 2 Km, Multimode, ST Connectors, 0 - 50 ° C, uses 2121 Power Supply

Specifications subject to change without notice.

## RS422 TO FIBER OPTIC BIT-DRIVERS®

### 2012



- ❑ Wall mounted Asynchronous Simplex or Full Duplex Optical Bit-Driver®
- ❑ Max Data Rate is 56 Kbps
- ❑ Input/Output Interface is 4 wire (plus ground) Terminal Block for RS-422
- ❑ Power Supply Cord for 110VAC. Order S.I. Tech 2012V for 230VAC
- ❑ Particularly suitable for use with GE, SIEMENS, and other Programmable Controllers in environments such as cargo container cranes at Seaports

### 2106



- ❑ Mini Asynchronous Simplex or Full Duplex Optical Bit-Driver®
- ❑ Max Data Rate is 56 Kbps
- ❑ Input/Output Interface DB-9 Female (Male optional)
- ❑ Connects directly to Terminal or by RS-422 2 pair cable
- ❑ Uses External Power Supply, S.I. Tech Model 2121 (110VAC) or 2164 (230VAC)
- ❑ T-Net Approved

### 212106\*

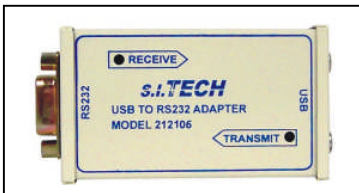

- ❑ RS-422 to USB
- ❑ Can be used to Connect Legacy RS-422 Interface to new PCs with only USB ports
- ❑ Supplied with virtual comport drivers
- ❑ Can be used with S.I.Tech #2106 RS-422 Fiber Bit-Driver®

### 2116



- ❑ Mini Synchronous Simplex or Full Duplex Optical Bit-Driver®
- ❑ Switch Selectable Synchronous Data Rates from 0.3 through 38.4Kbps
- ❑ Input/Output Interface is DB-9 Male (Female optional)
- ❑ Connects directly to Terminal or by RS-422 2 pair cable
- ❑ Designed to work with United Telecom C, X, and L BUS System
- ❑ Uses External Power Supply, S.I. Tech Model 2121 (110VAC) or 2164 (230VAC)

### 2176



- ❑ Mini Asynchronous Simplex or Full Duplex Optical Bit-Driver®
- ❑ Max Data Rate is 256 Kbps
- ❑ Designed for use with Micros POS Systems
- ❑ Works with S. I. Tech Model 2376 Card Mounted Bit-Driver
- ❑ Use External Power Supply S.I.Tech 2121 (110VAC – USA) or 2164 (230VAC)

## 2322



- ❑ Card Cage Mounted Asynchronous Simplex or Full Duplex Optical Bit-Driver®
- ❑ Max Data Rate is 56 Kbps
- ❑ Input/Output Interface is 8 Pin RJ-45 Female Connector
- ❑ Available on Eurocard, fits S.I. Tech Model 3000A, 19 inch Rack
- ❑ Designed to work with S.I. Tech Model 2106 or 2012 Bit-Drivers®

## 2376



- ❑ Card Cage Mounted Asynchronous Simplex or Full Duplex Optical Bit-Driver®
- ❑ Max Data Rate is 256 Kbps
- ❑ Input/Output Interface is 8 Pin RJ-45 Female Connector
- ❑ Switchable Line Termination provided
- ❑ Designed for use with Micros System
- ❑ Designed to work with S.I. Tech Model 2176 Mini Bit-Driver®

## 2857



- ❑ High Speed Stand Alone Asynchronous Simplex or Full Duplex Optical Bit-Driver®
- ❑ Max Data Rate is 20 Mbps
- ❑ Input/Output Interface is 4 Wire (plus Ground) Terminal Block for RS-422
- ❑ Power Supply Cord for 110VAC. Order S.I. Tech Model 2857V for 230VAC
- ❑ Available as 1/2/4 Channel in 1U high rack

## HFS 1172-132

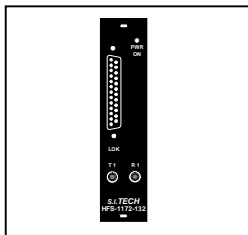

- ❑ Asynchronous/Synchronous RS422 Optical Bit-Driver®
- ❑ Eurocard Format for use in S.I. Tech Model 1000 Card Cage
- ❑ Max Data Rate is 76.8 Kbps (9.6 Kbps for Handshake Lines)
- ❑ Separately Switchable Slave/Not Slave, Asynch/Synch, DTE/DCE
- ❑ Switchable Synchronous Data Rate 150 bps through 76.8 Kbps (15 steps)

## HFS 1176-192

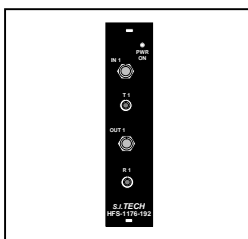

- ❑ Asynchronous RS422 Optical Bit-Driver®
- ❑ Eurocard Format for use in S.I. Tech Model 1000 Card Cage
- ❑ Max Data Rate is 2 Mbps
- ❑ Input/Output connectors are Triaxial with Isolated Outer Shield
- ❑ Termination is 220 ohms

## 2140\*

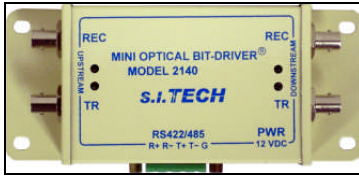

- ❑ RS422/RS485 (4 Wire) Multidrop Bit Driver
- ❑ Fiber in, Fiber out, RS422 Drop
- ❑ Up to 230 Kbps Data Rate
- ❑ Multimode or Single mode
- ❑ Repeater with RS422/RS485 (4 Wire) Add/Drop
- ❑ 12VDC Power

## 2281\*



- ❑ Opto Isolated RS422 to RS422
- ❑ DB9 Male to DB9 Female
- ❑ Data Rate to 2.5 Mbps
- ❑ Input Power 10 to 15VDC nor VAC
- ❑ 1000 VAC Isolated

## 2561\*



- ❑ Up to 115.2 Kbps Async Operation
- ❑ Extended Temp Range: -40 to +80°C
- ❑ Ruggedized Enclosure, Panel Mounting
- ❑ Complies with IEEE C37-90-1
- ❑ IEC 801 Surge Protection
- ❑ Conformal Coated – Environmental Protection
- ❑ Various AC/DC Power Options

## 2563\*



- ❑ “Three in One” Design RS232/422/485 to Fiber Bit-Driver
- ❑ Max Data Rate is 115.2 Kbps
- ❑ Multimode or Single mode
- ❑ DIN Rail Option
- ❑ 12VDC Power

## 2859\*



- ❑ 2 Channel RS422 Fiber Optic Bit Driver
- ❑ 1U High Case
- ❑ Up to 20 Mbps data rate
- ❑ Multimode or Single mode
- ❑ Uses Triax Connector for High Level Instrumentation, Security, Shielding. Used for Military Systems.

## 2860\*



- ❑ 4 Channel RS422 and TTL to Fiber Optic Bit Driver
- ❑ 1U High Case
- ❑ Up to 20 Mbps Data rate
- ❑ Multimode or Single mode
- ❑ Uses Triax (RS-422 Input) and BNC (TTL Output) to Connect to High Speed Network
- ❑ Used in Military System for High Security



## 2867\*



- ❑ 3 Channel RS422 and TTL Switchable Input to Fiber Optic Bit Driver with Continuous RS-422 and TTL Outputs
- ❑ 1U High Case
- ❑ Up to 20 Mbps Data rate
- ❑ Multimode or Single mode
- ❑ Uses BNC and Terminal Blocks
- ❑ Used in Military System

## 575-0656-004 and 005

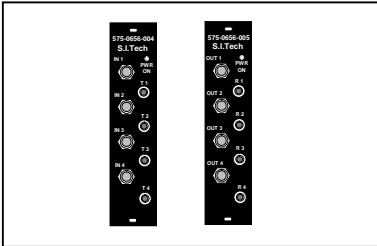

- ❑ 575-0656-004 is a 4 Channel Asynchronous High Speed RS-422 to Optical Transmitter Bit-Driver®
- ❑ 575-0656-005 is a 4 Channel Asynchronous High Speed RS-422 to Optical Receiver Bit-Driver®
- ❑ Max Data Rate is 10 Mbps
- ❑ Both are Eurocard format for use in S.I. Tech Model 1000 Card Cage and must be used in pairs for duplex operation
- ❑ Input/Output connectors are Triaxial with Isolated Outer Shield
- ❑ Transmitter Termination is 220 ohms

## Kit #9\*

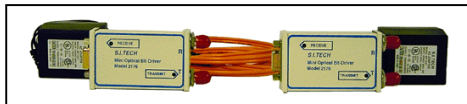

- ❑ POS Kit: 2 – 2176 Bit Driver (RS422), 2 – 2121 Power Supplies, 1 – 5202-010-8255 (10m) FO Cable Assembly, ST/ST, 1 – 7176 Cable Assembly
- ❑ Designed for Micros System Provides Electrical Isolation to Protect Computer, POS Terminals
- ❑ Long Distances are Possible

**TABLE E  
RS-422 TO FIBER MULTIPLEXERS**

Model No.	Package		Data Format			Power Option*	Data Connector**	Number of Channels	Point to Point	Distance *** Km				Weight LB/KG	Multimode (820 nm)/ Singlmode (1300 nm)	Trunk*** Fiber Connector	Remarks
	Stand Alone	Rack Mount	Max. Data Rate Kbps	Async	Sync					Control Signals	2	5	10				
2424	✓		256	✓		1,2	DB37 F	4	✓		✓	✓	✓	3/1.4	MM/SM	ST/SMA	uses 1 to 4 cable 7024
2428	✓		76.8	✓		1,2	DB37 F	8	✓		✓	✓	✓	3/1.4	MM/SM	ST/SMA	uses 1 to 8 cable 7028

\* Power Options: See "Power Options and How to Order" sheet (p. 106) for options and ordering instructions.

\*\* Pin outs are specified on data sheets

\*\*\* Distance: 2 km - STD, 5 km - L, 10 km - XL, 20 km - UL.

\*\*\*\*Other connector options for singlemode is FC.

Temperature range 0 - 50 degrees C unless shown otherwise.

**HOW TO ORDER**

Base Model Number XXXX	Power* 110V - STD 230VAC - V	Data Connector** M or F (F is STD on most models.)	Distance*** 2 Km - STD Other - Specify L, XL, or UL	Fiber and Connector		Temperature 0 - 50° C - STD Other - Call S.I. Tech
				Multimode (MM) - STD Other - Specify	Singlmode (SM)-Specify ST - STD Other - Specify	
e.g. 2424 = RS422 Async, 4 CH Fiber Multiplexer, 110VAC, DB37 F, 2Km, Multimode ST, 0-50 C						

Specifications subject to change without notice.

## RS-422 TO FIBER MULTIPLEXERS

2424



- ❑ Four Channel Asynchronous Simplex or Full Duplex Time Division Multiplexer Optical Bit-Driver®
- ❑ Max Data Rate is 256 Kbps on each channel
- ❑ Powered through 110 VAC line cord
- ❑ 230 VAC version available as S.I. Tech Model 2424V
- ❑ Each unit requires 4-to-1 RS-422 cable S.I. Tech #7024

2428



- ❑ Eight Channel Asynchronous Simplex or Full Duplex Time Division Multiplexer Optical Bit-Driver®
- ❑ Max Data Rate is 76.8 Kbps on each channel
- ❑ Powered through 110 VAC line cord
- ❑ 230 VAC version available as S.I. Tech Model 2428V
- ❑ Each unit requires 8-to-1 RS-422 cable S.I. Tech #7028



## **RS-485 PRODUCTS**

## FIELD BUSES

A Field Bus is a digital, serial, two-way multi-drop communication link among controllers and remote I/Os, sensors, actuators, and internet working components. In comparison to local area network (LAN), field buses are specialized for rugged industrial environment, determinism, bus powering and so on.

Field buses are covered by IEC Standards. Some of the more popular field buses are:

- Profibus: IEC IS 61158 type 1/3/10. Over 50% of process industry applications use Profibus
- Foundation Fieldbus: IEC IS 61158 Type 1/9
- MOD Bus: Developed by Modicon Inc. Now backed by Schneider Electric
- Inter Bus: IEC IS 61158 Type 8
- Device Net: IEC IS 62026 – 3 (2000)
- CAN Bus: IEC under development

Electric industry association (EIA), RS485 standard bus is used in many of these field buses.

## RS-485 PRODUCTS

### 1. Point to Point:

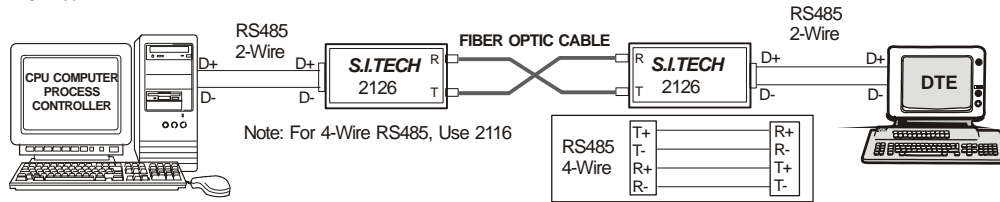

### 2. User Clusters:

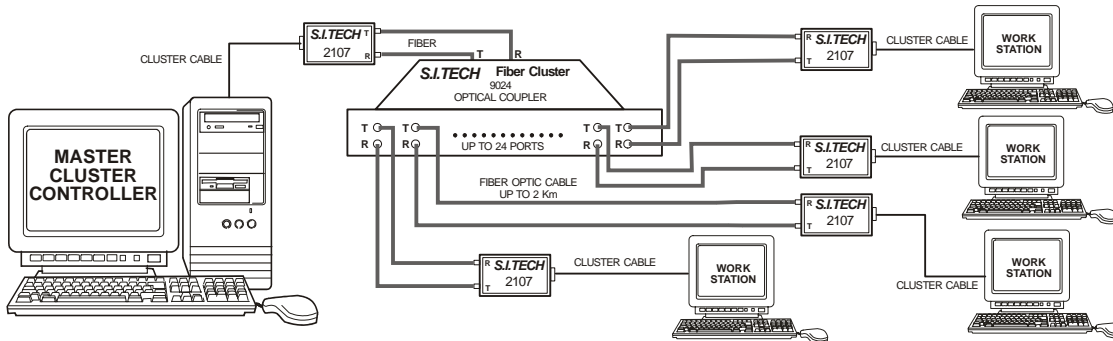

### 3. Proprietary Networks Using Other Bus Architecture:

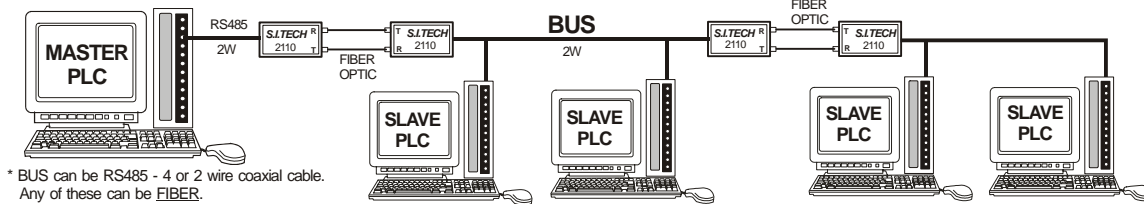

### 4. RS-485 Multidrop:

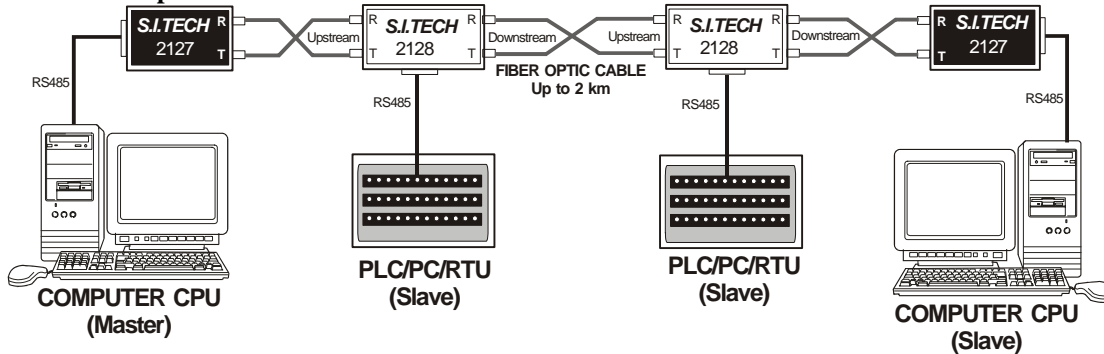

### 5. RS-485 Multiplexer:

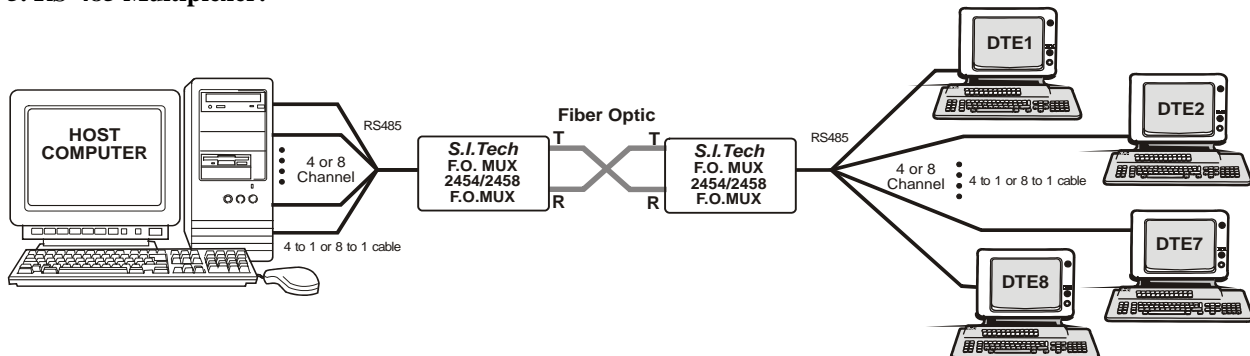

Note: For RS485 bus, end of line termination is required (typically 120 ohm resistor).

## RS-485

RS-485 (EIA-485) is a standard using twisted pair for extended distance communications and is used on process control, energy management, clustered computers, and security systems.

RS-485 is used as a 2 wire or 4 wire systems. In a 2 wire system, 2 wires (twisted pair) are used for both transmit and receive, thereby requiring communication in half-duplex mode. For example, data is sent from Point A to Point B and then the line is turned around (also called time out) to send data from Point B to Point A.

Data rates most commonly used range from 4800 bps all the way to 12 Mbps. As the data rate is increased data goes from Point A to Point B in less time so the line can be turned around much faster.

RS-485 is used for distributed data communication in a bus topology or “daisy chain”. Star, tree, or branch configurations are generally not recommended.

### RS-485 BUS

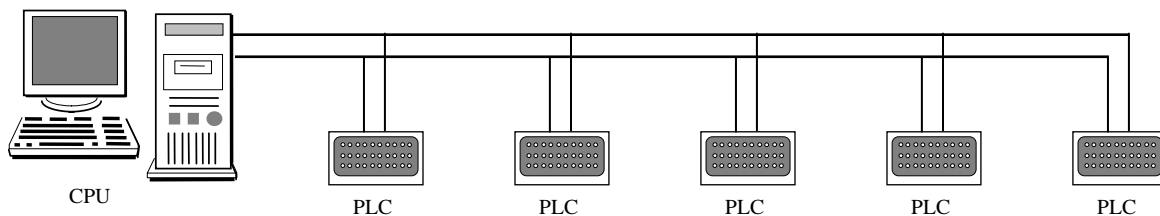

PLC=Programmable Logic Controller

For all RS-485 applications line termination is necessary – typically 100 to 120 ohms can terminate a line. Many manufacturers provide line termination in their equipment (auto terminating).

EIA-485 specifies generators and receivers capable of operating in balanced digital multipoint systems. The parameter values specified in this Standard are similar to those in TIA/EIA-422-B. These values allow generators and receivers to be designed that can be used to meet the requirements of both standards, (EIA-422 and 485).

EIA-485 is compatible with ISO/IEC 8482: 1993 *Information Technology – Telecommunications and information exchange between systems – Twisted pair multipoint interconnections*.

This Standard specifies the electrical characteristics of generators and receivers that may be employed when specified for the interchange of binary signals in multipoint interconnection of digital equipment. When implemented within the guidelines of this Standard, multiple generators and receivers may be attached to a common interconnecting cable.

An interchange system includes one or more generators connected by a balanced interconnecting cable to one or more receivers and terminating resistors.

## RS485 CONNECTORS

Please refer to the RS-422 section for discussion of data connectors.



**TABLE F  
RS-485 TO FIBER BIT-DRIVERS (MODEMS)**

Model No.	Package		Data Rate Up to kbps	Data Format		Power Option*	2 Wire Data Connector**	Multimode Fiber****		Singlemode Fiber Connector	Point to Point	Daisy Chain Multidrop	Distance ***			Weight LBJ/KG	Remarks
	Stand Alone	Mini		Async	Sync			Wavelength (SM-1300) nm	Connector				2	5	10		
2107	✓		1.8 M		✓	6	DB-9 F	ST/SMA	850		✓	✓	✓	✓	.25/1	Unisys NGEN	
2110	✓		9.6	✓		6	DB-9 M	ST/SMA	880	ST	✓	✓	✓	✓	.25/1	Johnson Controls Systems	
2126	✓		38.4	✓		6	DB-9 M	ST/SMA	880	ST	✓	✓	✓	✓	.25/1		
2127	✓		187.5	✓		6	DB-9 F	ST/SMA	850	ST	✓	✓	✓	✓	.25/1	Omron Protocol	
2128	✓		187.5	✓		6	DB-9 F	ST/SMA	850	ST	✓	✓	✓	✓	.25/1	Omron Protocol	
2140	✓		230K	✓		6	Terminal Block	ST/SMA	820	ST/FC	✓	✓	✓	✓	.4/2	Security Systems, Sensor Net	
2145	✓		12M	✓		10	DB-9 F	ST/SMA	820	ST/FC	✓	✓	✓	✓	1.0/5	Profibus - DP Repeater	
2228	✓		187.5	✓		4	DB-9 F	ST/SMA	850	ST	✓	✓	✓	✓	.25/1	Omron Protocol High Temperature 2128	
2310		✓	9.6	✓		1,2	Terminal Block	ST/SMA	820	ST	✓	✓	✓	✓	.5/2	3000 Rack Card / 2110 / 3520 Motherboard	
2316		✓	115	✓		1,2	RJ45	ST/SMA	820	ST/FC	✓	✓	✓	✓	.5/2	Eurocard/2616 Siemens	
2345		✓	9.6	✓		1,2	RJ45	ST/SMA	820	ST	✓	✓	✓	✓	.5/2	3000 Rack Card / 2110 / 3500 Motherboard	
2385		✓	38.4	✓		1,2	RJ45	ST/SMA	820	ST/FC	✓	✓	✓	✓	.5/2	3000 Rack Card / 2185 / 3500 Motherboard	
2562		✓	115	✓		1,2,3,10	DB-25 F	ST/SMA	820	ST/FC	✓	✓	✓	✓	1/1.5	Ruggedized RS-485	
2563		✓	115	✓		6	DB-25 F	ST/SMA	820	ST/FC	✓	✓	✓	✓	.4/2	"Three in One" RS-232/422/485	
2610		✓	9.6	✓		6	DB-9 F	ST/SMA	880	ST	✓	✓	✓	✓	.25/1	High Temperature 2110	
2616		✓	115	✓		6	DB-9 F	ST/SMA	820	ST/FC	✓	✓	✓	✓	.3/1	Siemens System	
2852	✓		1 M	✓	✓	1,2	Terminal Block	ST/SMA	820	ST/FC/SC	✓	✓	✓	✓	3/1.4	Omninet, MODBUS +	
212110 Kit #10			256	✓		--	DB-9/USB	--	--	--	--	--	--	--	0.25/0.1	USB to RS-485 Energy Management Kit 2 - 2110, 2 - 2121, 2 - 7110	

\* Power Options: See "Power Options and How to Order" sheet (p. 106) for options and ordering instructions.

\*\* Pin outs are specified in data sheets

Temperature range 0 - 50 degrees C unless shown otherwise.

Extended Temperature (ET) range available on some products.

\*\*\* Distances: 2 km - STD, 5 km - L, 10 km - XL, 20 km - UL

\*\*\*\* Use one wavelength throughout system except if WDM is used

Unisys is a trademark of Unisys Corp

Johnson Controls is a trademark of Johnson Controls Inc.

Omron is a trademark of Omron Electronics Inc

Texas Instruments is a trademark of Texas Instruments Inc.

Omninet is a trademark of Corvus Systems Inc.

**HOW TO ORDER**

Base Model Number	Power*	Data Connector**	Fiber and Connector		Temperature
			Multimode (MM)-STD	Singlemode (SM)-Specify	
XXXX	1, 110 VAC - STD 2, 230 VAC - V 4 & 6 - See Chart	M or F (F is STD on most models)	ST - STD Other-Specify	ST - STD Other-Specify	0 - 50° C - STD -40 to +80° C - ET Other - Call S.I. Tech

e.g. 2852 = RS-485 to Fiber Bit-Driver, 110 VAC, Terminal Block, 2 Km, Multimode, ST Connectors, 0 - 50 ° C

2126 = RS-485 to Fiber Bit-Driver, Needs S.I. Tech #2121 Power Supply, DB-9M, 2 Km, Multimode, ST Connectors, 0 - 50 ° C

Specifications subject to change without notice.

## RS-485 TO FIBER OPTIC BIT-DRIVERS®

**2110**



- Mini Asynchronous Half-Duplex Optical Bit-Driver®
- Data Rate up to 56 Kbps must be set at factory
- Designed for Johnson Controls System – N2 Bus and Bacnet
- Available in Eurocard format as Model 2345 for use in S.I. Tech Model 3000A Card Cage
- Standard Input/Output Interface is DB-9F Female Connector
- Din Rail Option is 2110-DIN
- Multimode or Single mode

**212110\***



- USB to Serial RS-485
- Can be used to connect legacy RS-485 interface to new PCs with only USB ports
- Supplied with Virtual Comport Drivers
- Can be used with S.I.Tech #2110 RS-485 to Bit-Driver®

**2110-DIN**



- Mini Asynchronous Half-Duplex Optical Bit-Driver®
- Data Rate up to 56 Kbps must be set at factory
- Designed for Johnson Controls System – N2 Bus and Bacnet
- Din rail version of 2110

**2126**



- Mini Synchronous Half Duplex Optical Bit-Driver®
- Data Rate is Switchable from 0.3 to 38.5 Kbps in 6 steps
- Input/Output Interface is RS-485 DB-9M Male Connector
- External Power Supply S.I. Tech Model 2121 (110 VAC) or 2164 (230 VAC)

**2127**



- Mini Synchronous Half Duplex Optical Bit-Driver®
- Data Rate is 187.5 Kbps
- Custom Designed to work with Omron PLC
- Input/Output Interface is RS-485 DB-9F Female Connector
- External Power Supply S.I. Tech Model 2121 (110 VAC) or 2164 (230 VAC)

**2128**



- Mini Synchronous Half Duplex Optical Bit-Driver®
- Data Rate is 187.5 Kbps
- Customized units available with different data rates
- Fiber Ports Repeat Data through the 2128 and Drop/Insert Data on the RS-485 Port (DB-9F Female Connector)
- RS-485 Port Inserts Data onto both Fiber Ports and gets Data dropped from either Fiber Port
- External Power Supply S.I. Tech Model 2121 (110 VAC) or 2164 (230 VAC)

## 2128/2228



- ❑ 2128 is Commercial Equipment/2228 is Mil-Spec.
- ❑ Mini Synchronous Half Duplex Optical Bit-Driver®
- ❑ Data Rate is 256 Kbps
- ❑ Fiber Ports Repeat Data through the 2128/2228 and Drop/Insert Data on the RS-485 Port (DB-9F Female Connector)
- ❑ RS-485 Port Inserts Data onto both Fiber Ports and gets Data dropped from either Fiber Port
- ❑ Host Powered (+12VDC on Pins 8 and 9 of DB-9F connector)
- ❑ Extended Temperature Range -40°C to +80°C
- ❑ Used with Military Systems

## 2140\*



- ❑ RS485 – 2 or 4 Wire Multidrop Bit Driver
- ❑ Fiber in, Fiber out, RS485 Drop
- ❑ Up to 230 Kbps Data Rate
- ❑ Multimode or Single mode
- ❑ Repeater with RS485 Drop/ADD
- ❑ Used with Security Systems, Sensors

## 2145\*



- ❑ RS485 – 2 Wire Profibus - DP
- ❑ Fiber in, Fiber out, RS485 Drop
- ❑ Data Rates, Switch Selectable to 12 Mbps
- ❑ Multimode, Single mode, or Plastic Fiber
- ❑ One or two fiber ports
- ❑ Used for Process Control
- ❑ Din Rail Mounting
- ❑ IFC 61168-2, EIA RS485A
- ❑ RS485 – 2 wire Modbus

## 2310



- ❑ Card Cage Mounted Asynchronous Half Duplex Optical Bit-Driver®
- ❑ Data Rate up to 56 Kbps must be set at factory
- ❑ Designed to Work with Johnson Controls System and with S.I. Tech Model 2110 Mini Bit-Driver®
- ❑ Eurocard Format, Fits S.I. Tech Model 3000A 19 inch Rack & 3520 Motherboard Bus
- ❑ Designed for RS485 Bus

## 2316\*

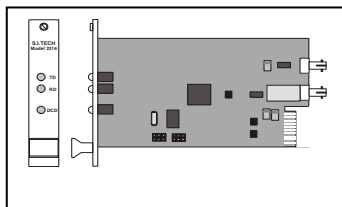

- ❑ Up to 115.2 Kbps, Async, 2 Wire, RS485
- ❑ Card Version of S.I.Tech 2616, Eurocard Size
- ❑ Multimode or Single mode
- ❑ Designed to Work with Siemens Systems or Other PLCs

## 2345



- ❑ Card Cage Mounted Asynchronous Half Duplex Optical Bit-Driver®
- ❑ Data Rate up to 56 Kbps must be set at factory
- ❑ Designed to Work with Johnson Controls System and with S.I. Tech Model 2110 Mini Bit-Driver®
- ❑ Input/Output Interface is 8-pin RJ-45 Female Connector
- ❑ Eurocard Format, Fits S.I. Tech Model 3000A 19 inch Rack

## 2562\*

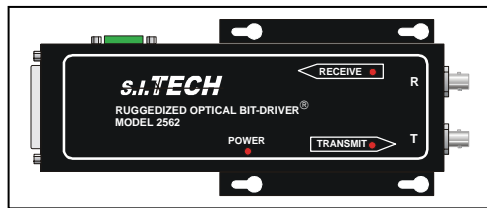

- ❑ Up to 115.2 Kbps, Async Operation, Switch Selectable
- ❑ Extended Temp Range -40°C to +80°C
- ❑ Ruggedized Enclosure, Panel Mounting
- ❑ Complies with IEEE C37-90-1
- ❑ IEC 801 Surge Protection
- ❑ Conformal Coated – Environmental
- ❑ Various AC/DC Power Option

## 2563\*



- ❑ “Three in One” Design RS/232/422/485 to Fiber Bit-Driver
- ❑ Max Data Rate is 115.2 Kbps, Switch Selectable
- ❑ Multimode or Single mode
- ❑ Din Rail Option

## 2610\*



- ❑ Mini Asynchronous Half Duplex Optical Bit-Driver®
- ❑ Data Rate up to 56 Kbps must be set at factory
- ❑ Designed to work with Johnson Controls System-N2 Bus or other PLC
- ❑ Standard Input/Output Interface is DB-9M Male Connector
- ❑ Extended Temperature Range (-40°C to +80°C) Version of Model 2110

## 2616\*



- ❑ Up to 115.2 Kbps, Async, 2 Wire, RS485
- ❑ Extended Temp Range -40°C to +80°C
- ❑ Multimode or Single mode
- ❑ Designed to work with Siemens System or Other PLCs

## 2852

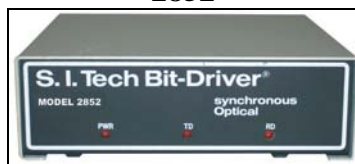

- ❑ Synchronous Simplex or Half Duplex Optical Bit-Driver®
- ❑ Normal Operating Data Rate is 1 Mbps
- ❑ Designed to work with Omninet by Corvus Systems Inc and MODBUS+
- ❑ Stand Alone – 110 VAC or 230 VAC power cord
- ❑ Input/Output Interface RS-485 2-wire + Ground Terminal Block

## Kit #10

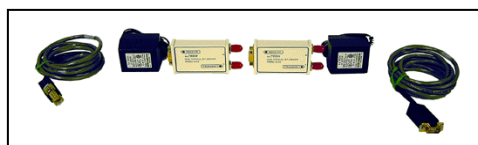

- ❑ Din Rail Option
- ❑ Energy Management System Kit for Plug and Play Consist of :
  - 2 – 2110 Mini Bit Driver
  - 2 – 2121 Power Supply
  - 2 – 7110 Cable Assemblies

**TABLE G  
RS-485 TO FIBER OPTIC MULTIPLEXERS**

Model No.	Package		Data Format			Power Option*	Data Connector**	Number of Channels	Point to Point	Multidrop	Distance Km			**Weight LB/KG	Multimode (820 nm)/ Singlemode (1300 nm)	Trunk**** Fiber Connector	Remarks
	Stand Alone	Rack Mount	Max. Data Rate Kbps	Async	Sync						Control Signals	2	5				
2454	✓	Option	256	✓		1,2	DB37 F	4	✓		✓	✓	✓	MM/SM	ST/SMA	uses 1 to 4 cable 7054	
2458	✓	Option	76.8	✓		1,2	DB37 F	8	✓		✓	✓	✓	MM/SM	ST/SMA	uses 1 to 8 cable 7058	

\* Power Options: See "Power Options and How to Order" sheet (p. 106) for options and ordering instructions.

\*\* Pin outs are specified on data sheets

\*\*\* Distance: 2 km - STD, 5 km - L, 10 km - XL, 20 km - UL.

\*\*\*\* Other connector options for singlemode are SC and FC.

Temperature range 0 - 50 degrees C unless shown otherwise.

**HOW TO ORDER**

Base Model Number XXXX	Power* 110V-STD 230VAC-V	Data Connector** M or F (F is STD on most models.)	Distance*** 2 Km - STD Other - Specify L, XL, or UL	Fiber and Connector		Temperature 0 - 50° C - STD Other - Call S.I. Tech
				Multimode (MM) - STD ST - STD Other - Specify	Singlemode (SM)-Specify ST - STD	
e.g. 2454 - RS-485 Async, 4 CH Fiber Multiplexer, 110VAC, DB37 F, 2Km, Multimode ST, 0-50 C						

Specifications subject to change without notice.

## RS-485 TO FIBER MULTIPLEXERS

### 2454



- ❑ Four Channel Asynchronous Half Duplex Time Division Multiplexer Optical Bit-Driver®
- ❑ Data Rate up to 256 Kbps must be set at factory
- ❑ Powered through 110 VAC line cord
- ❑ 230 VAC version available as S.I. Tech Model 2454V
- ❑ Each unit requires 4-to-1 RS-485 cable S.I. Tech #7054

### 2458



- ❑ Eight Channel Asynchronous Half Duplex Time Division Multiplexer Optical Bit-Driver®
- ❑ Data Rate up to 76.8 Kbps must be set at factory
- ❑ Powered through 110 VAC line cord
- ❑ 230 VAC version available as S.I. Tech Model 2458V
- ❑ Each unit requires 8-to-1 RS-485 cable S.I. Tech #7058

## **TTL PRODUCTS**

## TTL PRODUCTS

### 1. Point to Point:

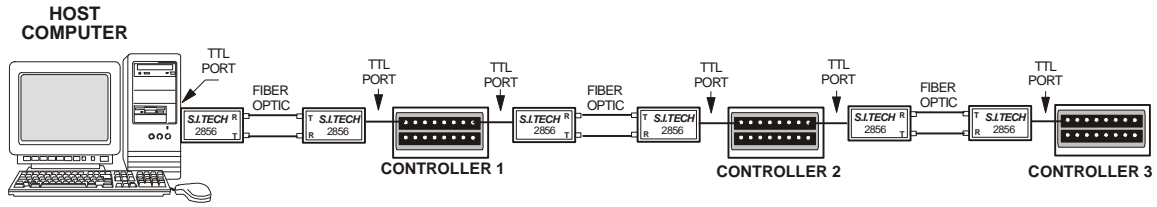

### 2. Multiplexer:

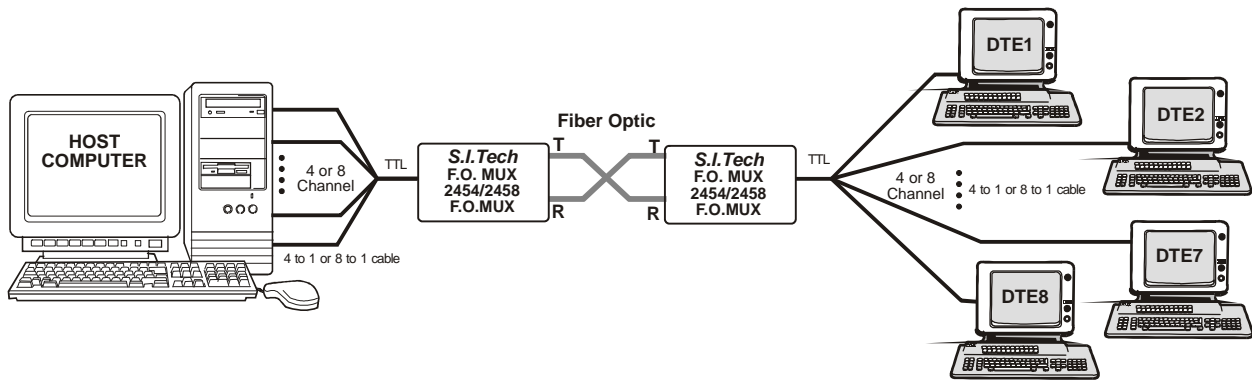



## TABLE H TTL TO FIBER OPTIC BIT-DRIVERS®

Model No.	Package			Data Format			Multimode Fiber		Single Mode Fiber		Weight LB/KG	Remarks						
	PCB Stand Alone	Mini Card	Rack Mount	Max. Data Rate Mbps	Async	Sync	Power Option*	BNC	Triax	Connector			Wavelength nm	1300 nm	1500 nm	Connector****	Point to Point	Distance *** Km
2805				20	√		4			SMA	820	-	-	√	√	√	.1/.05	Dip Package Transmitter
2806				20	√		9.4			SMA	820	-	-	√	√	√	.1/.05	Dip Package Receiver
2817				20	√		6	√		ST/SMA	820	ST/FC	ST/FC	√	√	√	0.4/2	One Way or Two Way
2856	√			20	√		1.2	√		ST/SMA	820	ST/FC	ST	√	√	√	3/1.4	Available as 1/2/4 Channel
2860		√		20	√		1.2	√		ST/SMA	820	ST/FC	ST	√	√	√	0.1/0.05	4 CH, TTL of RS-422, 1U Rack PCB Version
2865	√			20	√		9	√		ST/SMA	820	ST/FC	ST	√	√	√	6/2.8	3 CH Switchable TTL & RS-422, 1U Rack
2867			√	20	√		1.2	√		ST/SMA	820	ST/FC	ST	√	√	√	5/2	Card for 1000 rack, 2 CH Receiver
575-0656-006			√	2	√		-	√		ST/SMA	820	ST/FC	-	√	√	√	5/2	Card for 1000 rack, 2 CH Transmitter
575-0656-007			√	2	√		-	√		ST/SMA	820	ST/FC	-	√	√	√	5/2	8 CH Multiplexer Card, 1000 Rack
HFS-1175-546			√	0.2	√		-	√		ST	820	-	-	√	√	√	5/2	Consists of 1 -2817T, 1 - 2817R, 2 - 2121 PS, 1 -5201-003-8255 FO Cable ST/ST
Kit #7				20	√		-											

\* Power Options: See "Power Options and How to Order" sheet (p. 106) for options and ordering instructions.

\*\* Pin outs are specified in data sheets

Temperature range 0 - 50 degrees C unless shown otherwise. Extended Temperature (ET) range available on some products.

\*\*\* Distance: 2 km - STD, 5 km - L, 10 km - XL, 20 km - UL

\*\*\*\* Use one wavelength throughout system except if WDM is used

\*\*\*\*\* Only Models having fiber connector entry in this column are available in single mode

### HOW TO ORDER

Base Model Number XXXX	Power* 1. 110 VAC - STD 2. 230 VAC - V 6. See Chart	Data Connector** M or F (F is STD on most models)	Distance*** 2 Km - STD Other - Specify L, XL, or UL	Fiber and Connector		Temperature 0 - 50° C - STD -40 to +80° C - ET Other - Call S.I. Tech
				Multimode (MM)-STD ST-STD Other-Specify	Singlemode (SM)-Specify ST-STD Other-Specify	

Specifications subject to change without notice.

## TTL TO FIBER OPTIC BIT-DRIVERS®

2856



- ❑ Asynchronous Simplex or Full Duplex Optical Bit-Driver®
- ❑ Max Data Rate is 20 Mbps
- ❑ Supports 50 or 75 ohm coax
- ❑ Power, Transmit Data, and Receive Data LED indicators

575-0656-006

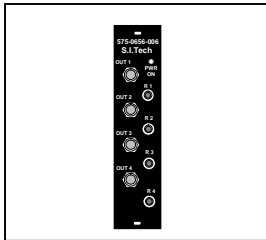

- ❑ Card Cage Mounted Optical-to-TTL Bit-Driver® Receiver
- ❑ Data Rate is 2 Mbps
- ❑ Four Channels
- ❑ Data Connector is isolated BNC
- ❑ For use in S.I. Tech Model 1000 Card Cage
- ❑ Work with Model 575-0656-007 Transmitter

575-0656-007

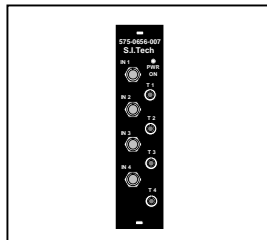

- ❑ Card Cage Mounted TTL-to-Optical Bit-Driver® Transmitter
- ❑ Data Rate is 2 Mbps
- ❑ Four Channels
- ❑ Data Connector is isolated BNC
- ❑ For use in S.I. Tech Model 1000 Card Cage
- ❑ Works with Model 575-0656-006 Receiver

DIP MODELS 2805

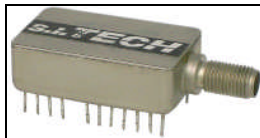

- ❑ Metal 24 pin DIP configuration TTL-to-Optical Bit-Driver® Transmitter
- ❑ Data Rate is DC to 20 Mbps NRZ
- ❑ Connection is by solder pads or DIP socket
- ❑ Package size is 1.2x0.75x0.37 inches
- ❑ SMA Connector

2806

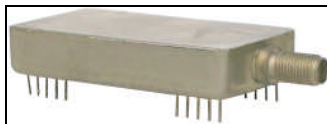

- ❑ Metal 40 pin DIP configuration Optical-to-TTL Bit-Driver® Receiver
- ❑ Data Rate is DC to 20 Mbps NRZ
- ❑ Connection is by solder pads or DIP socket
- ❑ Package size is 2.0x1.12x0.37 inches
- ❑ SMA Connector

2817\*

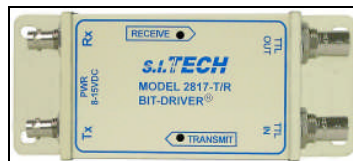

- ❑ One way (T & R) or Two way (Full Duplex) TTL
- ❑ Miniature Units
- ❑ Flange Mounting
- ❑ Data rate to 20 Mbps
- ❑ Multimode or Single mode
- ❑ 5VDC or 12VDC Power

## 2860\*



- ❑ 4 CH TTL or RS-422
- ❑ Data rate to 20 Mbps
- ❑ Triax and BNC Connectors
- ❑ 1U high rack 19"
- ❑ Military Systems, Instrumentation

## 2865\*

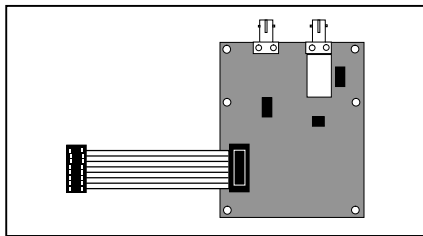

- ❑ Unmounted Circuit Card configuration TTL-to-Optical Bit-Driver® Transmitter-Receiver.
- ❑ Data Rate is DC to 20Mbps NRZ
- ❑ Connection is to solder pads in 16 pin DIP configuration
- ❑ Card size is 3¾ x 3 inches with 2.4 x 2.55 inch mounting centers.
- ❑ Multimode is standard, Single mode optional

## 2867\*



- ❑ 3 Channel RS422 and TTL Switchable Input to Fiber Optic Bit Driver with Continuous RS-422 and TTL Outputs
- ❑ Up to 20 Mbps Data rate
- ❑ 1U High Case
- ❑ Multimode or Single mode
- ❑ Uses BNC and Terminal Blocks
- ❑ Used in Military System

## TTL TO FIBER OPTIC MULTIPLEXERS

### 2006 (See RS232 Section)



- ❑ TTL is an Optional Interface on Model 2006

### HFS 1175-546

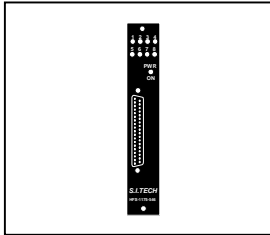

- ❑ 8 Channel TTL Low Speed Multiplexer
- ❑ Series 1000 Chassis
- ❑ Data Rate is 19.2 Kbps on each channel
- ❑ Multimode or Single mode
- ❑ Uses DB-37 Connector

**VIDEO, AUDIO,  
AND  
ALARM PRODUCTS**

## VIDEO, AUDIO, AND ALARM SYSTEMS

Closed circuit television typically consists of a video camera and a TV monitor that uses a baseband video signal at 6 MHz bandwidth as opposed to broadband video used in cable television or broadcast TV Channels 2 to 900, which uses 950 MHz total bandwidth.

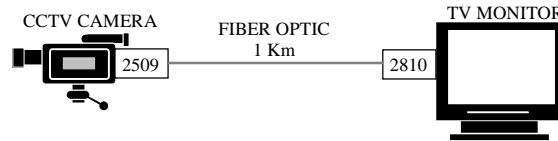

Baseband video is also used with computers. Computer monitors use red, green, blue, and sync pulse schemes. Each color uses a full 6 MHz bandwidth. To remote a computer monitor from a computer, all three colors and sync pulse need to be transmitted from Point A to Point B.

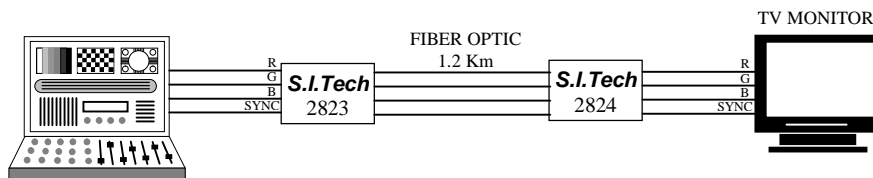

Audio or analog signals are typically low frequency signals usually from 0.03 Hz to 40 KHz range. Voice communications uses these signals. If digitized, audio requires 64 Kbps bandwidth per channel. The standard telephone system uses an analog system. However, all long distance telephone uses digital communication i.e. T1 at 1.54 Mbps (24 Channel voice).

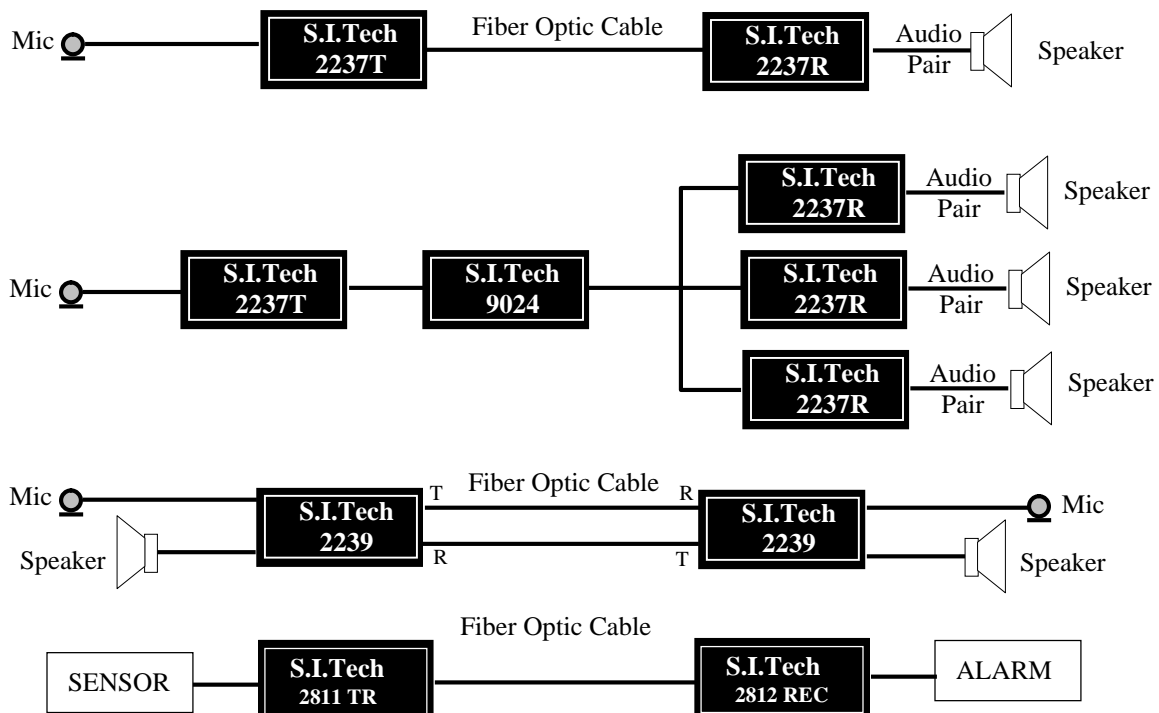

Analog systems are also used for alarm systems or on/off systems such as closing and opening doors. Relay contacts are used.

## TABLE I VIDEO AUDIO AND ALARM PRODUCTS

Model No.	Package		Bandwidth bps	Power Option*	Connectors	Fiber Connection		Point to Point	Weight LB/KG	Remarks
	Stand Alone	Rack Mount Card				MM	SM			
<b>Video</b>	2379	✓	15M	1,2	BNC	ST	ST	✓	0.4/2	1 or 2 Ch, TR Card Video
	2380	✓	15M	1,2	BNC	ST	ST	✓	0.4/2	1 or 2 Ch, REC Card Video
	2509	✓	15M	6	BNC - F	ST/SMA	ST	✓	.25/1	1 Ch CCTV Xmtr
	2509IL	✓	15M	6	BNC - F	ST/SMA	ST	✓	.25/1	1 Ch CCTV Xmtr
	2809	✓	15M	1,2	BNC - F	ST/SMA	ST	✓	2/1	2 to 4 Ch CCVT Video Xmtr
	2810	✓	15M	1,2	BNC - F	ST/SMA	ST	✓	2/1	2 to 4 Ch CCTV Video Rcvr
	2823	✓	30M	1,2	BNC - F	ST/SMA	ST	✓	2/1	4 Ch RGB Video Xmtr
	2824	✓	30M	1,2	BNC - F	ST/SMA	ST	✓	2/1	4 Ch RGB Video Rcvr
	2829	✓	Digitized Video	1,2	BNC/DB9/RCA	SC	ST	✓	3/1.4	Bi-Directional Video/Audio/Date
	HFS-1142	✓	7M	1,2	BNC - F	ST/SMA	ST	✓	.5/2	2 Ch Video Rcvr
	HFS-1144	✓	45M	1,2	BNC - F	ST/SMA	ST	✓	.5/2	2 Ch Video Xmtr
	HFS-1146	✓	40M	1,2	BNC - F	ST/SMA	ST	✓	.5/2	1 Ch each way Video Xmtr-Rcvr
	Kit #6	✓	15M			ST	ST			2809/2810 Kit CCTV
	Kit #15	✓	Digitized Video			SC	SC			2829 Kit - Security System
	<b>Audio/Analog</b>	2237T	✓	40K	1,2	RCA	ST/SMA	ST	✓	3/1.4
2237R		✓	40K	1,2	RCA	ST/SMA	ST	✓	3/1.4	Listener - Audio REC
2239		✓	40K	1,2	RCA	ST/SMA	ST	✓	3/1.4	Two way Audio
HFS-1151		✓	100K	1,2	Twinax	ST/SMA	ST/SMA	✓	.5/2	2 Ch Audio Xmtr
HFS-1152		✓	100K	1,2	Twinax	ST/SMA	ST/SMA	✓	.5/2	2 Ch Audio Rcvr
<b>Alarm</b>	HFS-1153	✓	100K	1,2	Twinax	ST/SMA	ST/SMA	✓	.5/2	1 Ch each way Audio Xmtr-Rcvr
	Kit #5	✓				ST	ST			Audio Kit - 2237T/2237R/FO Cable
	2311	✓	-	24VDC	Terminal Block	ST	ST	✓	.9/4	Card Version 2811
	2312	✓	-	24VDC	Terminal Block	ST	ST	✓	.9/4	Card Version 2812
	2811	✓	***	+12 VDC	Terminal Block	ST/SMA	ST/SMA	✓	2/1	Transmitter
	2812	✓	***	+12 VDC	Terminal Block	ST/SMA	ST/SMA	✓	2/1	Receiver
	2813	✓	***	+12 or 24 VDC	Terminal Block	ST/SMA	ST/SMA	✓	2/1	Transmitter-Receiver
	A estot Kit	✓	-		Terminal Block	ST	ST	✓	6/3	Antenna Control, Military System "Thaad" Program

\* Power Options: See "Power Options and How to Order" sheet (p. 106) for options and ordering instructions.  
 \*\* Pin outs are specified in data sheets  
 Temperature range 0 - 50 degrees C unless shown otherwise.  
 Extended Temperature (ET) range available on some products.

### HOW TO ORDER

Base Model							
Number	XXXX	Power*	1. 110 VAC - STD 2. 230 VAC - V 6. See Chart	Data Connector**	M or F (F is STD on most models)	Fiber Multimode (MM)-STD	Temperature
						ST-STD	0 - 50° C - STD -40 to +80° C - ET Other - Call S.I. Tech

e.g. 2823 = 4 Channel RGB Video Transmitter, 110 VAC, BNC Female, ST Connectors, 0-50 Degree C

## CCTV VIDEO TO FIBER OPTIC BIT-DRIVERS®

### 2379\*



- ❑ 1 or 2 CH. CCTV Video Transmitter Card
- ❑ Use with 2810 or 2380 Cards
- ❑ 3001 rack 19" – hold 12 cards, 24 CH
- ❑ Multimode or Single mode

### 2380\*



- ❑ 1 or 2 CH. CCTV Video Receiver Card
- ❑ Use with 2509/2809/2379 Transmitters
- ❑ 3001 rack 19" – hold 12 cards, 24 CH
- ❑ Multimode or Single mode

### 2509

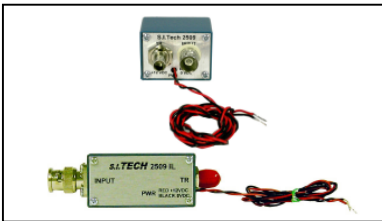

- ❑ Mini Optical CCTV Video Bit-Driver® Transmitter
- ❑ System Bandwidth is 10Hz to 15MHz
- ❑ Powered by +12VDC from camera or external power supply S.I.Tech 2121 (110VAC/12VDC) or 2164 (230VAC/12VDC)
- ❑ Video Connector is 75 ohm BNC Female
- ❑ Works with S.I. Tech Model 2810 Receiver
- ❑ In Line – Connects to Camera (IL)

### 2809

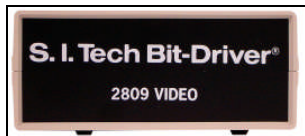

- ❑ Stand Alone Optical CCTV Video Bit-Driver® Transmitter
- ❑ System Bandwidth is 10Hz to 15MHz
- ❑ Powered by 110V or 230V line cord
- ❑ Video Connector is 75 ohm BNC Female
- ❑ Works with S.I. Tech Model 2810 Receiver
- ❑ Also available as 2809-2, 2809-3 and 2809-4, which are 2, 3 and 4 channels, respectively
- ❑ Alternately available in 19 inch Rack

### 2810

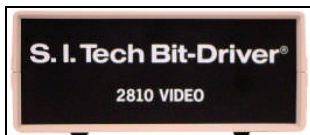

- ❑ Stand Alone Optical CCTV Video Bit-Driver® Receiver
- ❑ System Bandwidth is 10Hz to 15MHz
- ❑ Powered by 110V or 230V Line Cord
- ❑ Video Connector is 75 ohm BNC Female
- ❑ Works with S.I. Tech Model 2509 and 2809 Transmitters
- ❑ Also available as 2810-2, 2810-3 and 2810-4, which are 2,3 and 4 channels, respectively
- ❑ Alternately available in 19 inch Rack

### 2823

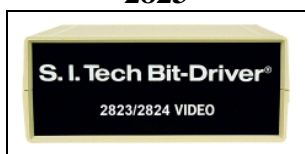

- ❑ Stand Alone Optical RGB Video Bit-Driver® Transmitter
- ❑ Four Channels; R, G, B and Sync
- ❑ System Bandwidth is 10Hz to 30MHz
- ❑ Input impedance is 75 ohms. BNC Female Coaxial Connector each channel
- ❑ Powered by 115V or 230V Line Cord



## 2824



- Stand Alone Optical RGB Video Bit-Driver® Receiver
- Four Channels; R, G, B and Sync
- System Bandwidth is 10Hz to 30MHz
- Receiver output impedance is 75 ohms. BNC Female Coaxial Connector each Channel
- Powered by 115V or 230V Line Cord

## 2829\*



- Bidirectional Video/Audio/Data to fiber
- Multimode or Single mode
- Digitized 8-bit high resolution video Composite, S-Video, or Component
- Mono or Stereo Audio
- Data: RS232/422/485/TTL
- NTSC or PAL Format
- Color or Black and White
- Plug and Play
- AC or DC Power

## Kit #6\*

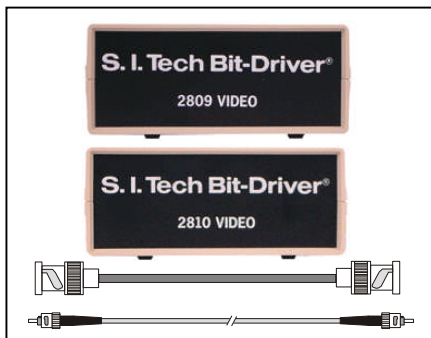

- 1 - 2809 Video Transmitter
- 1 - 2810 Video Receiver
- 1 - 5201-010-8255 (10m), 1F multimode, ST/ST FO cable assembly
- 2 - 75 ohm BNC cable assemblies

## Kit #15\*



- Complete CCTV Video Security System Kit
- 2 - 2829 Bit Driver
- 1 - 5001-15" LCD TV Monitor
- 1 - 5010 CCTV Video Color Camera
- 1 - 7202-300-8264, 300 meter (1000 ft) ruggedized FO cable assembly SC/SC
- Optional - Camera/TV/Cable length

## HFS-1142

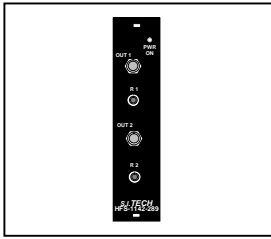

- ❑ Card Cage Mounted Optical Video Bit-Driver® Receiver
- ❑ Two Channels
- ❑ Frequency response to 7MHz
- ❑ Output impedance 75 ohms. BNC Female Coaxial Connector
- ❑ Eurocard format. Fits S.I. Tech Model 1000 Card Cage
- ❑ Works with HFS-1144 Transmitter

## HFS-1144

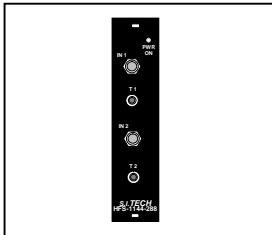

- ❑ Card Cage Mounted Optical Video Bit-Driver® Transmitter
- ❑ Two Channels
- ❑ Frequency response 6Hz to 40MHz
- ❑ Input impedance 75 ohms. BNC Female Coaxial Connector
- ❑ Eurocard format. Fits S.I. Tech Model 1000 Card Cage
- ❑ Works with HFS-1142 Receiver

## HFS-1146

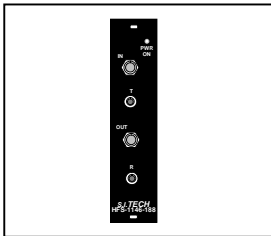

- ❑ Card Cage Mounted Optical Video Bit-Driver® Transmitter/Receiver
- ❑ Two Channels (one transmit, one receive)
- ❑ Transmitter frequency response 6Hz to 40MHz
- ❑ Receiver frequency response to 40MHz
- ❑ Input Output impedances 75 ohms. BNC Female Coaxial Connector
- ❑ Eurocard format. Fits S.I. Tech Model 1000 Card Cage

## AUDIO (ANALOG) TO FIBER OPTIC BIT-DRIVERS®

**2237T\***



- Stand Alone Optical Audio Transmitter Bit-Driver®
- System Bandwidth is 10Hz to 20KHz
- Input impedance is 600 ohms unbalanced
- Audio terminals on terminal block
- Powered by 110VAC Line Cord. Add "V" to Model number for 230VAC version, 12-24VDC Option
- Use with 2237R Audio Receiver

**2237R\***



- Stand Alone Optical Audio Receiver Bit-Driver®
- System Bandwidth is 10Hz to 20KHz
- Will drive 8 ohm speaker connected to output terminals
- Powered by 110VAC Line Cord. Add "V" to Model number for 230VAC version, 12-24VDC Option
- Use with 2237T and two optical fibers for full-duplex operation

**2239\***



- Two way audio TR/REC Bit-Driver®
- System Bandwidth is 10Hz to 20KHz
- Multimode or Single mode
- AC or DC Power Option

**HFS-1151**

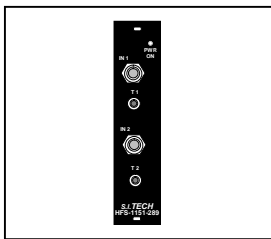

- Card Cage Mounted Optical Analog Audio Bit-Driver® Transmitter
- Two Channels
- Frequency response 6Hz to 100KHz
- Input impedance 600 ohms. Twinax connector
- Eurocard format. Fits S.I. Tech Model 1000 Card Cage
- Works with HFS-1152 Receiver

**HFS-1152**

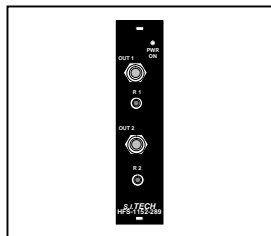

- Card Cage Mounted Optical Analog Audio Bit-Driver® Receiver
- Two Channels
- Frequency response 6Hz to 100KHz
- Output impedance 600 ohms. Twinax connector
- Eurocard format. Fits S.I. Tech Model 1000 Card Cage
- Works with HFS-1151 Transmitter

**HFS-1153**

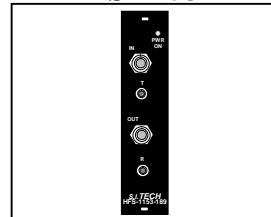

- Card Cage Mounted Optical Analog Audio Bit-Driver® Transmitter-Receiver
- Two Channels -one transmit/one receive
- Frequency response 6Hz to 100 KHz
- Input and Output impedance 600 ohms. Twinax connector
- Eurocard format. Fits S.I. Tech Model 1000 Card Cage

# S.I. TECH

---

## Kit #5\*



- 1 – 2237T Audio Transmitter
- 1 – 2237R Audio Receiver
- 1 – 5201-010-8255, 10m 1F ST/ST cable

## ALARM SYSTEM TO FIBER OPTIC BIT-DRIVERS®

### 2311\*



- Alarm (Sensor) ON/OFF Transmitter
- Card version of 2811
- 3000 Rack
- Multimode or Single mode

### 2312\*



- Alarm (Sensor) ON/OFF Receiver
- Card version of 2812
- 3000 Rack
- Multimode or Single mode

### 2811



- Stand Alone Optical On-Off Bit-Driver® Transmitter
- Transmits 10KHz Optical square wave when power is applied
- Input power +12VDC to screw terminals
- Must be used with Model 2812 Receiver to complete link
- Multimode or Single mode

### 2812



- Stand Alone Optical On-Off Bit-Driver® Receiver
- Detects 10KHz optical square wave from Model 2811 Transmitter and activates 4PDT relay
- Relay contacts rated 2 Amps, 500VAC between open contacts. Each contact is connected to a screw terminal
- Must be used with Model 2811 transmitter to complete link
- Input power +12VDC to screw terminals
- Multimode or Single mode

### 2813



- Stand Alone Optical On-Off Bit-Driver® Link
- Performs functions of one Model 2811 Transmitter and one Model 2812 Receiver
- Input power +12VDC or +24VDC to screw terminal
- One Model 2813 needed at each end of link

### AESFOT KIT



- Antenna control, Military Systems “THAAD” program
- Multimode or Single mode
- Chassis holds 3 – 2311 or 3 – 2312 and 2 power supplies
- Rack has redundant power supply



## **USB PRODUCTS**

## USB TECHNOLOGY: UNIVERSAL SERIAL BUS (USB)

USB's main attraction is that it makes adding peripherals to your computer very easy. It enables you to connect peripherals to the outside of the computer so you don't have to open your PC.

Introduced in 1995, the USB standard was developed by industry leaders including DEC, IBM, Intel, Microsoft, and Compaq. Today, PCs and peripherals feature at least one USB port. Peripherals include everything from printers to cameras.

A USB peripheral simply plugs right into the port and USB devices are completely hot-swappable. USB host controllers automatically detect when peripherals are connected to or disconnected from a port.

USB uses a tiered star topology, meaning that USB devices called hubs can serve as connection ports for other USB devices. Only one device needs to be plugged into your PC. A single USB port can support up to 127 devices.

USB 1.1, the original USB standard, has two data rates: 12 Mbps for devices such as disk drivers that need high-speed throughput and 1.5 Mbps for devices like joysticks that use much less bandwidth.

USB 2.0, Hi-Speed USB 2.0, gained wide acceptance in the industry. It increases the speed of the peripheral-to-PC connection from 12 Mbps to 480 Mbps, or 40 times faster.

This increase in bandwidth enhances the use of external peripherals that require high throughput, such as CD/DVD burners, hard drives, digital cameras, video equipment, etc. A USB 2.0 and USB 1.1 peripherals.

A newer USB standard, USB On-The-Go (OTG), enables portable devices, such as PDAs, digital music players, and mobile phones, to connect to each other without the need for a PC host.

USB 3.0, a new high speed standard is under development. It is expected to work up to 4 Gbits/sec or higher , or 10 times faster than USB 2.0.

USB 2.0 is limited to about 5 meters length from PC and it is expected that USB 3.0 may be limited to 2.0 meters from host computer.

There are four types of USB connectors: Type A, Type B, the Mini A, and Mini B. USB 1.1 specifies Type A and Type B. USB 2.0 specifies Type A, Type B, and the Mini B. The Mini A connector was developed as part of the USB OTG specification and is used for smaller peripherals, such as cell phones and PDAs.

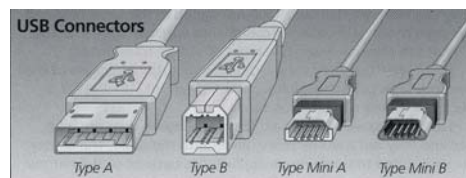

To overcome distance limitations of USB 1.1 and USB 2.0, S.I.Tech has developed fiber optic extenders for each type. USB 2.0 Fiber Optic Extender will also support USB 1.1 applications. USB 2.0 running at 480 Mbps does impose other restrictions such as multimode fiber bandwidth, particularly, 62.5/125 micron fiber operating at 850 nm. User needs to review his/her application on specific fiber type that should be used. If single mode fiber is used along with appropriate USB 2.0 extenders made for single mode, then bandwidth limitations do not apply.



**TABLE J**  
**USB TO FIBER OPTIC BIT-DRIVERS®**

Model No.	Package			Data Rate Up to Mbps	Data Format		Power Option*	Multimode Fiber ****		Singlemode Fiber Connector	Point to Point	HUB Port 1 to 4	Distance *** Km			Weight LB/KG	Remarks
	Stand Alone	Din-Rail	Mini Card		Mount Card	rack Dized		USB 1.1	USB 2.0				Connector	Wavelength (SM-1300) nm	2		
2170	√	√		12	√		2164	ST	820	ST	√		√		√	1/45	USB 1.1
2171	√	√		12	√		2164	ST	820	ST	√	√	√		√	1/45	USB 1.1, 1 to 4ports
2172	√	√		480		√	2164	SC	1310	SC	√		√		√	1/45	USB 2.0
2173	√	√		480		√	2164	SC	1310	SC	√	√	√		√	1/45	USB 2.0, 1 to 4 ports
2179		√		480		√					-		-		-	-	2 USB 2.0 ports, IEEE 802.11G
2174			√	54	√	√	2165	-	-	-	√		-		-	4/2	2 Ports RS232/422/485
2175			√	54	√	√	2165	-	-	-	√	√	-		-	.45/2	30 meters wireless, IEEE 802.11G
3170				12	√		2164	ST	820	ST	√		√		√	2/9	USB 1.1, Highly Shielded
3171				12	√		2164	ST	820	ST	√		√		√	2/9	USB 1.1, 1 or 2 ports, Highly Shielded
3172				480		√	2164	ST	1310	ST	√		√		√	2/9	USB 2.0, Highly Shielded
3173				480		√	2164	ST	1310	ST	√	√	√		√	2/9	USB 2.0 1 or 2 ports, Highly Shielded
212005				0.1	√	√	-	-	-	-	-		-		-	.25/1	USB to RS-232
212106				0.25	√	√	-	-	-	-	√		-		-	-	USB to RS-422
212110				0.25	√	√	-	-	-	-	√		-		-	-	USB to RS-485
2181	√	√		480	√	√	2166	LC	850/1310	LC	√		√		√	1/45	Full speed USB 1.1 & USB 2.0, UHCI & OHCI
2182	√	√		480	√	√	2166	LC	850/1310	LC	√	√	√		√	1/45	USB 2.0 1 to 4 ports Hub, Full speed, USB 1.1 and USB 2.0

Specifications subject to change without notice.

## USB TO FIBER OPTIC BIT-DRIVERS®

### 2170\*



- USB 1.1 to Fiber Optic Bit Driver
- Data Rate 1.5 Mbps and 12 Mbps
- Multimode or Single mode
- Eliminate Distance Limitation of USB 1.1, 2km Multimode, Longer Distances with Single Mode
- Use with 2171
- Protects host computer from lightning or high voltage as it is optically isolated from attached devices.

### 2171\*



- USB 1.1 – 4 Port Hub to Fiber Optic Bit Driver
- Use with 2170
- Eliminate Distance Limitation of USB 1.1, 2 km Multimode , longer distances with Single mode
- Data Rate 1.5 Mbps and 12 Mbps

### 2172\*



See 2181 EOL 3/30/2010

- USB 2.0 to Fiber Optic Bit Driver
- Data Rate 1.5, 12 Mbps and 480 Mbps
- Multimode or Single mode
- Eliminate Distance Limitation of USB 2.0, extended distance can be used with fiber
- Protect host computer from lightning or high voltage as it is optically isolated from attached devices.
- Use with 2173

### 2173\*



See 2181 EOL 3/30/2010

- USB 2.0 – 4 Port Hub to Fiber Optic Bit Driver
- Data Rate from 1.5, 12 Mbps and 480 Mbps
- Multimode or Single mode
- Can be Provided as 1, 2,3 or 4 Port Hub
- Use with 2172

### 2179\*



- USB to 4 Port Hub Fiber Optic Bit Driver, 2 Port Hub, 2 Port RS-232 or 422 or 485

## USB TO FIBER OPTIC AND WIRELESS BIT-DRIVERS®

**3170\***



- ❑ USB 1.1 to Fiber Optic Bit Driver Tempest (Highly Shielded)
- ❑ Data rate 1.5 Mbps and 12 Mbps
- ❑ Multimode or Single mode
- ❑ Secure Communication and Long Distances
- ❑ Use with 2171 or 3171

**3171\***



- ❑ USB 1.1 to Fiber Optic Bit Driver Tempest 1 or 2 Port Hub (Highly Shielded)
- ❑ Data rate 1.5 Mbps and 12 Mbps
- ❑ Multimode or Single mode
- ❑ Secure Communication and Long Distances
- ❑ Use with 2170 or 3170

**3172\***



- ❑ USB 2.0 to Fiber Optic Bit Driver Tempest (Highly Shielded)
- ❑ Data rate 1.5 Mbps, 12 Mbps and 480 Mbps
- ❑ Multimode or Single mode
- ❑ Secure Communication and Long Distances
- ❑ Optically Isolates Host Computer, Protects from attached Devices
- ❑ Use with 2173 or 3173

**3173\***



- ❑ USB 2.0 to Fiber Optic Bit Driver Tempest (Highly Shielded), 1 or 2 Port Hub
- ❑ Data rate 1.5 Mbps, 12 Mbps and 480 Mbps
- ❑ Multimode or Single mode
- ❑ Secure Communication and Long Distances
- ❑ Use with 2172 or 3172

**212005\***



- ❑ USB to Serial RS-232
- ❑ Can be used to connect legacy RS-232 interface to new PC with only USB ports
- ❑ Supplied with virtual comport driven

**2174\***



- ❑ USB 2.0 to Wireless Bit Driver
- ❑ Supports to USB 1.0, 1.1 and 2.0. IEEE 802.11G, 2.4 GHz Band
- ❑ Use with 2175
- ❑ 64 bit WEP wireless security

2175\*



- ❑ USB 2.0 Hub – 4 Port Wireless
- ❑ Maximum reach extending USB to 30m wirelessly
- ❑ Supports Full Speed USB 1.1 and high speed USB 2.0
- ❑ Use with 2174

2181\*



- ❑ USB 1.1 and 2.0 to Fiber Bit Driver
- ❑ Data rate from 1.5 to 480 Mbps
- ❑ Multimode or Single mode
- ❑ Eliminate Distance Limitations of USB 2.0 Extended Distance with Fiber
- ❑ Protect host computer from lightning or high voltages as it is optically isolated from attached devices
- ❑ USB 2.0 host converter is not required, works with USB 1.1 or 2.0 Controller
- ❑ Small Size
- ❑ LC Fiber Connector
- ❑ Din Rail Mounting
- ❑ Works with Windows Vista Software and National Instrument Controllers
- ❑ Use with 2182 (Replaces 2172)

2182\*



- ❑ USB 1.1 and 2.0 – 4 Port Hub
- ❑ Data rate from 1.5 to 480 Mbps
- ❑ Multimode or Single mode
- ❑ Eliminate Distance Limitations of USB 2.0 - Extends Distance with Fiber
- ❑ Protect host computer from lightning or high voltages as it is optically isolated from attached devices
- ❑ USB 2.0 host converter is not required, works with USB 1.1 or 2.0 Controller
- ❑ Small Size
- ❑ LC Fiber Connector
- ❑ Din Rail Mounting
- ❑ Works with Windows Vista Software and National Instrument Controllers
- ❑ Use with 2181 (Replaces 2173)

USB 1.0 Kit #4\*



- ❑ 1 - 2170 Bit-Driver
- ❑ 1 - 2171 Bit-Driver
- ❑ 2 - 2164 Power Supplies
- ❑ 1 - 5202-010-8255 33' (10M) 2 Fiber Indoor Multimode Cable - ST/ST
- ❑ 1 - 7170 Type A to Type B USB Cable

# S.I.TECH

## USB 2.0 Kit #11



See 2181/2182 EOL 3/30/2010

- ❑ 1 - 2172 Bit-Driver
- ❑ 1 - 2173 Bit-Driver
- ❑ 2 - 2164 Power Supplies
- ❑ 1 - 5202-010-8264 33' (10M) 2 Fiber Indoor Multimode Cable - SC/SC
- ❑ 1 - 7172 Type A to Type B USB 2.0 Cable

## USB 2.0 Wireless Kit #16\*



- ❑ 1 - 2174 Wireless Bit-Driver
- ❑ 1 - 2175 Wireless Bit-Driver
- ❑ 2 - Power Supplies
- ❑ 1 - 7172 Type A to Type B USB 2.0 Cable

## 212106\*



- ❑ USB to Serial RS-422
- ❑ Can be used to connect legacy RS-422 interface to new PCs with only USB ports
- ❑ Supplied with virtual comport drivers
- ❑ Can be used with S.I.Tech #2106 RS-422 to fiber Bit-Drivers

## 212110\*



- ❑ USB to Serial RS-485
- ❑ Can be used to connect legacy RS-485 interface to new PCs with only USB ports
- ❑ Supplied with virtual comport drivers
- ❑ Can be used with S.I.Tech #2110 RS-485 to fiber Bit-Drivers



## **LAN/WAN PRODUCTS**

## LAN/WAN PRODUCTS (Local Area and Wide Area Networks)

### 1. Ethernet:

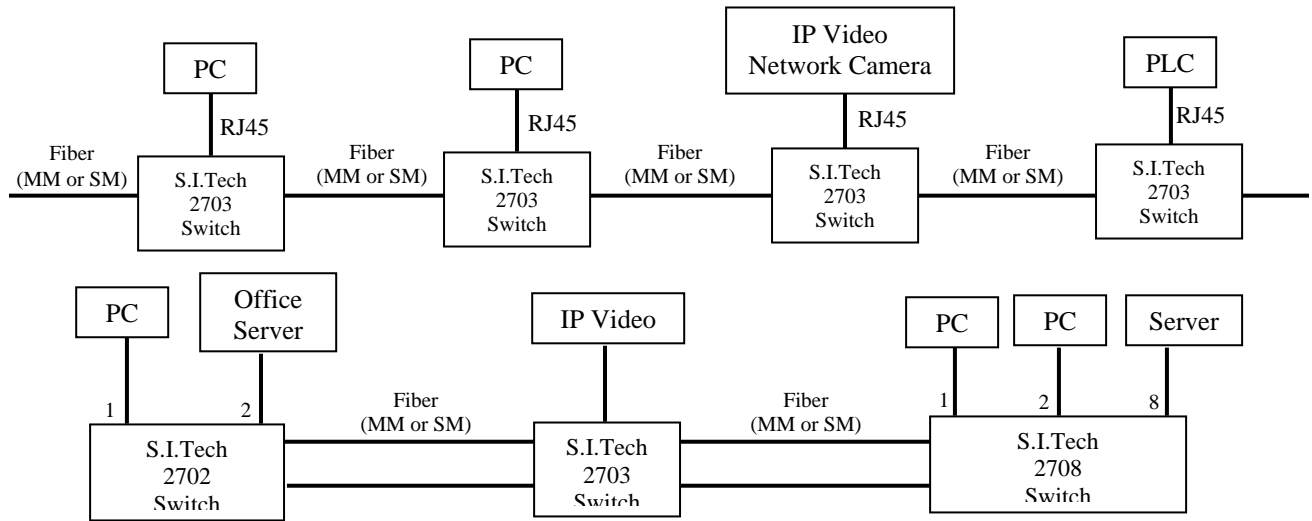

### 2. 100/1000 Mbps Single mode Ethernet:

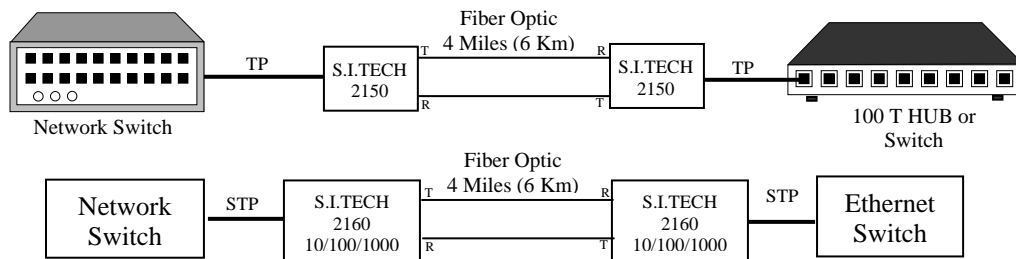

### 3. ARCNET:

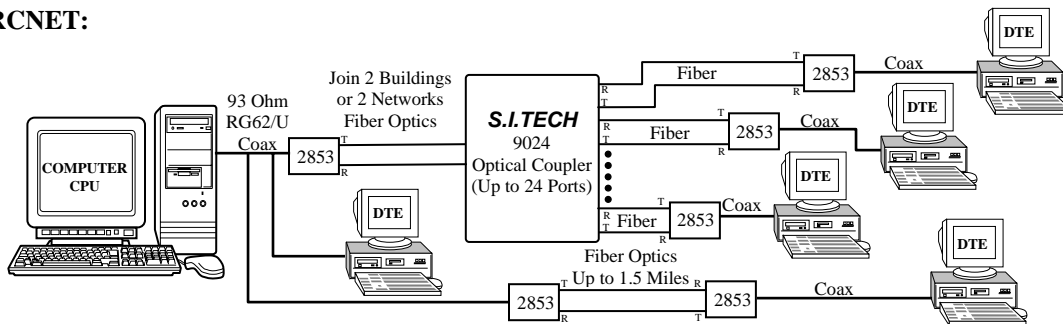



## LAN/WAN

With a personal computer on each desk, so-called distributed data processing emerged with a need to connect all PC's in a given area and to share data files together. This is how the local area network (LAN) was born.

Today LAN's can have hundreds or even thousands of users (nodes) connected together. In large networks, segments are created so that problems can be easily isolated and eliminated. Over the years there have been many networking schemes, each with advantages and disadvantages. Today, Ethernet is the most prominent LAN in offices.

While LAN's are adequate for small companies with one office, larger companies with multiple offices need more complex networks.

So we have:

- MAN – Metropolitan Area Network
- WAN – Wide Area Network
- Global Net – Global - Many countries
- Internet – Global - Worldwide
- Intranet - Within the same company-multiple networks, networked
- Mobile Net - Cellular phone network
- Telephone Network - Global
- SAN - Storage Area Network

In discussing LOCAL AREA or WIDE AREA NETWORK, typically OSI (Open Systems Interconnection), a reference model, is used as shown below.

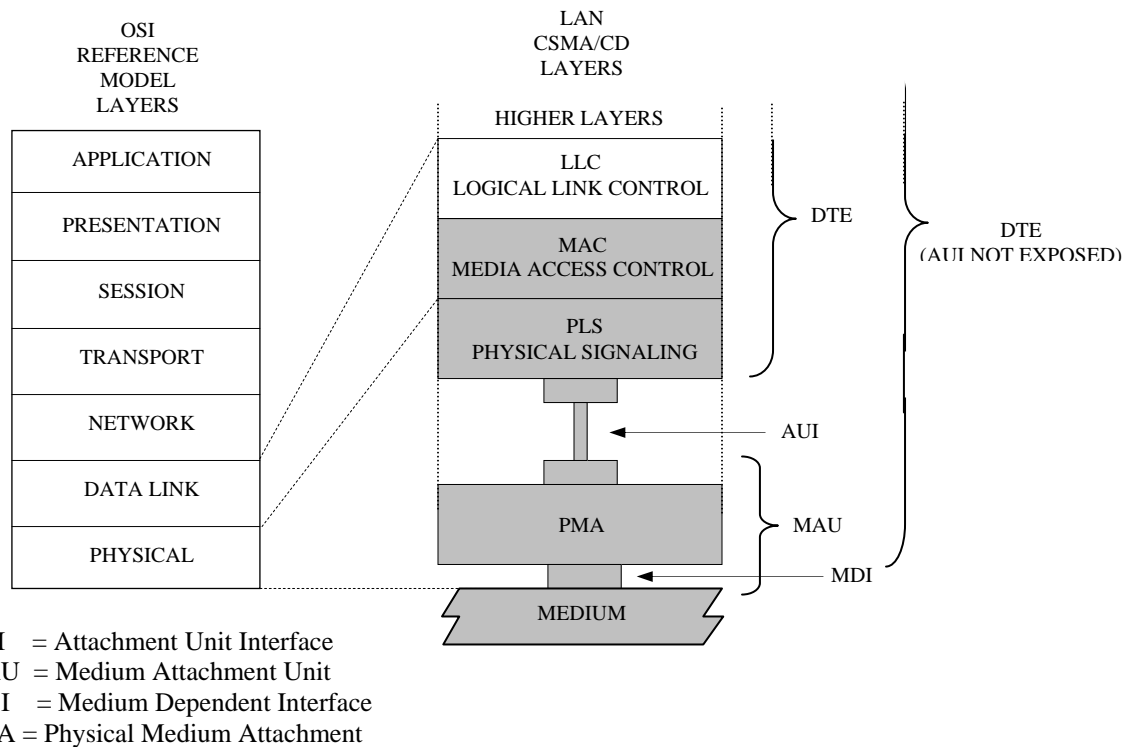

### ISO/IEC 8802-3 (IEEE 802.3) relationship to the ISO/IEC Open System Interconnection (OSI) reference model.

S.I. Tech Fiber Optic products fall into physical and data link layers of the model.

## LOCAL AREA NETWORKS

As the term implies, computers located in a given area such as an office or factory can be networked (connected together) in a particular scheme. Today's Local Area Networks are comprised of many special inter connecting schemes, each with unique benefits and disadvantages. Basic configurations are:

**1. Bus Network: all users are attached to a common BUS.**

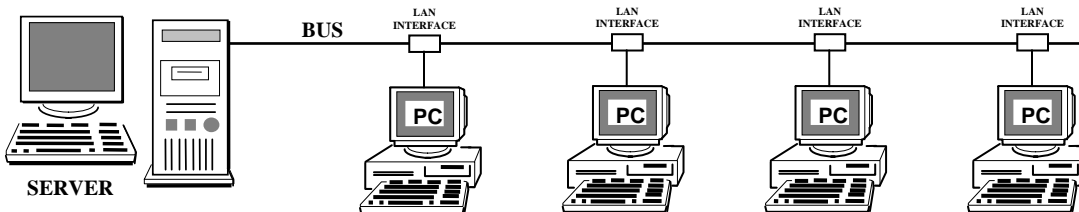

**2. Ring Network**

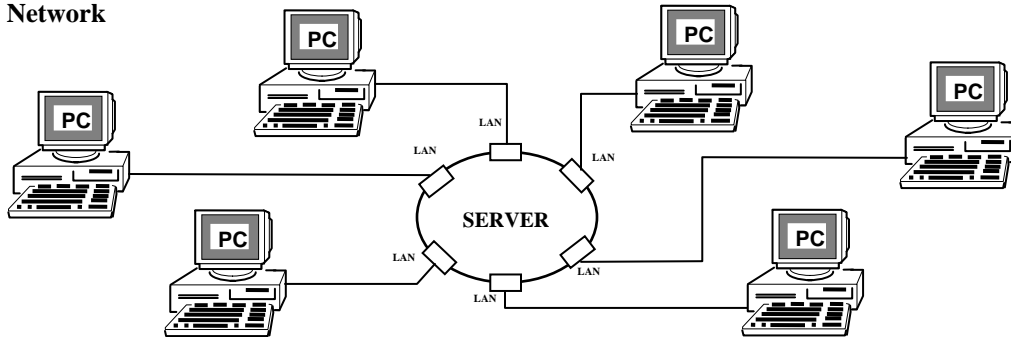

**3. Star Network**

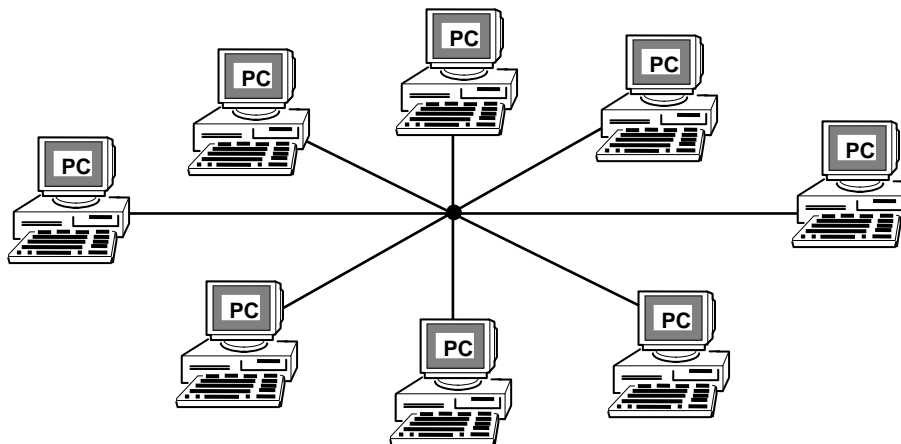

**4. Tree Network: Combining these concepts into various fashions, today's complex LAN's are set up.**

IEEE – Institute of Electrical and Electronic Engineers have developed many LAN standards and new ones are continually created. Some of the present standards are:

- IEEE 802.1 - Relationship between IEEE and ISO model
- IEEE 802.2 - Network control protocol
- IEEE 802.3 - Ethernet Local Area Network
- IEEE 802.4 - Map/Top Local Area Network
- IEEE 802.5 - Token Ring Local Area Network
- IEEE 802.6 - MAN Network
- IEEE 802.7 - Broad Band Local Area Network
- IEEE 802.8 - Fiber Optic CSMA/CD
- IEEE 802.9 - Integrated Voice and Data
- IEEE 802.10 - Interoperable LAN/MAN security
- IEEE 802.11 - Wireless LAN
- IEEE 802.12 - Demand priority access method. Repeater spec.
- IEEE 802.14 - Cable TV based Broad Band Network
- IEEE 802.15 – Wireless Personal Area Network (WPAN)
- IEEE 802.16 – Metropolitan Area Network - Wireless

A short description on the more common networks is given below:

ARCNET:	A token passing BUS network, developed by Datapoint. Runs at 2.5Mbps and uses 93 ohm coaxial cable as a medium.
Ethernet:	Is a BUS network using CSMA/CD scheme. Today's business world predominately uses Ethernet as a networking protocol. Ethernet is well developed with low cost devices for 10 and 100Mbps. 1 gigabit and 10 Gbps systems are available and higher speeds under development. (40 and 100 Gbps)
Token Ring:	The token access procedure used on a network with a sequential or ring topology. Popularized by IBM. Runs at 4 and 16Mbps. FDDI, which is token ring, runs at 100Mbps.
Map/Top:	The token passing BUS network for the Manufacturing Industry.
FDDI:	Fiber distributed data and token ring network running at 100Mbps has counter rotating rings for redundancy.
Internet:	Global computer network, where everyone has access to Worldwide Web. Wide ranging access speeds are available.
Telephone Network:	Global network of all telecommunications equipment, telephones.
SONET:	Synchronous optical network – used for high speed telecom connections. Speed ranges from OC-1 to OC-768. (51Mbps to 40Gbps.)
Fire wire	IEEE 1394 – 800 Mbps

Common features of all fiber optic networking products offered by S.I. Tech:

Industry refers to S.I. Tech products by various names such as line drivers, media converters, transceivers, etc. The basic concept is to use fiber optics wherever possible and required or specified. Fiber can be used in place of unshielded twisted pair (UTP), shielded twisted pair (STP), coax, twinax, radio, or satellite connection with appropriate interface and product design.

While fiber optics can exceed distance limitations of various networking specifications, network engineers should consider networking issues such as time out, software limitations, equipment compatibility, etc.

Typical operating distances for fiber optic cables

Fiber Size (Microns)	Nominal Attenuation dB/Km				Distance* Km				Distance* Feet				Bandwidth MHz/Km			
	660 nm	850 nm	1310 nm	1550 nm	660 nm	850 nm	1310 nm	1550 nm	660 nm	850 nm	1310 nm	1550 nm	660 nm	850 nm	1310 nm	1550 nm
1000	200	-	-	-	0.1	-	-	-	330	-	-	-	-	-	-	-
200	-	7.0	-	-	-	1.0	-	-	-	3300	-	-	-	20	-	-
50	-	3.0	1.0	-	-	2	5	5	-	6600	16000	-	-	600	600	-
62.5	-	3.5	1.0	-	-	2	5	5	-	6600	16000	-	-	200	600	-
10 SM	-	-	0.35	0.25	-	-	10	20	-	-	33000	66000	-	-	Unspecified	-

\*Longer distances are possible and available with special designs. Various connector options are available, such as SMA/ST/FC/SC/MT-RJ/LC

S.I. Tech supplies indoor/outdoor Fiber Optic cables and cables with connectors. Fiber Optic Repeater/Mode (size) Converters: S.I. Tech model 2062 and 2082 are designed to convert multimode fiber any size to any other size or can also be used to convert any size multimode to single mode fiber. The 2062 has a maximum data speed of 20 Mbps and the 2082 has a maximum data speed of 1000 Mbps.

2062-MM/MM	2062-MM/SM	2062-SM/SM
2082-MM/MM	2082-MM/SM	2082-SM/SM

Additionally, these products can also be used to extend the distance of a fiber optic link or overcome excessive link loss (attenuation).

Power Cord: 3 Pin International Standard Cord

Status Indicators: All products come with status indicator LEDs to show network activity, fiber link activity, power, collision, and other indicators. Refer to chart or individual data sheet for specifics.

All S.I. Tech products are UL listed where applicable. Many are CE compliant. Meet ROHS and WEE regulations,

**TRANSMISSION MEDIA:**

- Twisted Pair
- Coaxial Cable
- Fiber Optics
- Satellite
- Radio

TWISTED PAIR – is the lowest cost transmission medium available within buildings, as most of the time, telephone wiring exists in all buildings. Over the years, cable manufacturers have significantly improved transmission properties of unshielded twisted pair (UTP) or shielded twisted pair cables (STP). These are now classified by EIA/TIA (Electronic Industries Association/Telecommunication Industry Association) “category of performance” standards based on carrier frequency in Hz or MHz. This translates roughly into the following data rates in Mbps.

CAT	Cable Type	Max Data Rate
1	UTP	Below 1 Mbps
2	UTP	4 Mbps
3	UTP/STP	16 Mbps
4	UTP/STP	20 Mbps
5	UTP/STP	100 Mbps
5e	UTP/STP	200 Mbps
6	UTP/SFTP*/STP	1000 Mbps
7	SFTP	1/10 Gbps

\*Foil Shield

COAXIAL CABLES: IBM SNA, ARCNET, and ETHERNET are coaxial cable based networks. Both IBM SNA and ARCNET use 93 ohm, low capacitance cable. Ethernet Trunk Cable is typically 50 ohm thick coax (yellow cable) and Ethernet Distribution Cable is thin coax, RG-58/U.

As we all know, attenuation (loss) in coaxial cable goes up with frequency and distance. The higher the data rate and the longer the distance, the higher the loss. This limits the distance that cable can be used effectively without amplification (Boosters, Repeaters). Cable television, which typically uses 75 ohm coaxial cable, uses repeaters on poles to boost the signal.

## TABLE K ETHERNET LAN

Network	Model #	Package		Data Rate up to Mbps	Status Indicators	Power* Option	Data** Connection	Fiber Connection Multimode 820 nm	Fiber Connection Singlemode 1300 nm	Distance Km ***			Standard Network	Weight LB/KG	Remarks
		Stand Alone	M/ni Card							2	5	10			
Ethernet	2062	✓		25	✓	5	FIBER IN/OUT	ST/SMA	ST	✓	✓	✓		.5/2	Fiber Optic Repeater/Converter
	2082	✓	✓	1000	✓	5	FIBER IN/OUT	ST	ST/FC/SC	✓	✓	✓		.5/2	Fiber Optic Repeater/Converter
	2150	✓	✓	100	✓	8	RJ45	ST	ST	✓	✓	✓	✓	.5/2	Fast Ethernet
	2160	✓	✓	10/100/1000	✓	8	RJ45	SC	SC	✓	✓	✓	✓	.5/2	Gigbit Ethernet
	2350	✓	✓	10	✓	1.2	RJ45	ST	ST	✓	✓	✓	✓	.5/2	10Mbps Ethernet
	2350-10/100A	✓	✓	10/100	✓	1.2	RJ45	ST/SC	SC	SC	✓	✓	✓	.5/2	10/100Mbps Ethernet
	2351	✓	✓	10	✓	ISA BUS	ISA BUS	ST/SMA	ST	ST	✓	✓	✓	.5/2	ISA BUS Card
	2361-10/100/1000	✓	✓	10/100/1000	✓	1.2	RJ45	SC	SC	SC	✓	✓	✓	.5/2	10/100/1000Mbps Ethernet
	2550	✓	✓	10	✓	6	RJ45	ST	ST	ST	✓	✓	✓	.5/2	Ethernet 10 Base FL or FOIRL
	3150	✓	✓	10/100	-	8	R-4ES	ST	ST	ST	✓	✓	✓	1.0/0.5	Highly Shielded 2150
	3152	✓	✓	10/100	-	-	R-45R/45S	ST	ST	ST	✓	✓	✓	1.0/0.5	Ethernet Filter
	3160	✓	✓	10/100/1000	-	8	R-4ES	ST	ST	ST	✓	✓	✓	1.0/0.5	Highly Shielded 2160

### ETHERNET SWITCH

2702	✓		10/100	✓	1.2	RJ45	ST/SC	SC	SC	✓	✓	✓	✓	1/4	2 Ports RJ45, 1 Fiber
2703	✓	✓	10/100	✓	1.2	RJ45	ST/SC	SC	SC	✓	✓	✓	✓	1/4	1 Ports RJ45, 2 Fiber
2704	✓	✓	10/100	✓	1.2	RJ45	ST/SC	SC	SC	✓	✓	✓	✓	1.5/7	4 Ports RJ45, 1 Fiber
2708	✓	✓	10/100	✓	1.2	RJ45	ST/SC	SC	SC	✓	✓	✓	✓	2/9	8 Ports RJ45, 1 Fiber

\* Power Options: See "Power Options and How to Order" sheet (p. 106) for options and ordering instructions.

\*\* Pin outs are specified in data sheets

Temperature range 0 - 50 degrees C unless shown otherwise.

Extended Temperature (ET) range available on some products.

\*\*\* Distance: 2 km - STD, 5 km - L, 10 km - XL, 20 km - UL

\*\*\* While on Fiber side you can go long distances, check Network Timing & Distance limitations

### HOW TO ORDER

Base Model	Number	Power*	Data Connector**	Distance**	Fiber and Connector	Temperature
XXXX	1, 110 VAC - STD	M or F	Multimode (MM)-STD	2 Km - STD	Singlemode (SM)-Specify	Temperature
	2, 230 VAC - V	(F is STD on most models)	ST - STD	Other - Specify L, XL, or UL	Other-Specify	0 - 50° C - STD
	5.6 & 8 - See Chart		Other-Specify		Other-Specify	-40 to +80° C - ET
						Other - Call S.I. Tech

e.g. 2150 = Fast Ethernet to Fiber Bit-Driver, Needs S.I. Tech #2164 Power Supply, RJ-45, 2 Km, Multimode, ST Connectors, 0-50 Degrees C

Specifications subject to change without notice.

## TABLE L LAN/WAN

Network	Model #	Package		Card	Data Rate up to Mbps	Status Indicators	Power** Option	Data ** Connector	Fiber Connection Multimode 820 nm	Distance Km ***			Standard Network	Weight LB/KG	Remarks
		Stand Alone	Mini Rack							Fiber Connector Singlemode 1300 nm	2	5			
Arcnet	2353		✓		2.5	✓	1, 2	BNC F	ST/SMA	ST/FO/SC	✓	✓	✓	.5/2	ARCNET Card, 3000 Rack
	2853	✓	-		2.5	✓	1, 2	BNC F	ST/SMA	ST/FO/SC	✓	✓	✓	3/1.4	ARCNET
<b>IBM - SEE IBM SECTION</b>															
Omninet (RS-485)	2852	✓			1	✓	1, 2	Terminal Block	ST/SMA	ST/FO/SC	✓	✓	✓	3/1.4	RS-485 Network
<b>WAN/Internet/ Telecom</b>															
T-1	2390			✓	1.54	✓	1,2,3	RJ45	ST/SMA	ST/FO/SC	✓	✓	✓	1/4	T-1
	2890-2R-ASP-1		✓		1.54	✓	1,2,3	DB15	ST/SMA	ST/FC	✓	✓	✓	6/2.7	2CH, T1
	2890-4R-ASP-1		✓		1.54	✓	1,2,3	RJ48	ST/SMA	ST/FC	✓	✓	✓	6/2.7	4CH, T1
E-1	2391			✓	2.04	✓	1,2,3	BNC	ST/SMA	ST/FO/SC	✓	✓	✓	1/4	E-1
T-1/E-1	2890	✓	✓		1.54	✓	1,2,3	RJ45	ST/SMA	ST/FO/SC	✓	✓	✓	3/1.4	T-1
	2891	✓	✓		2.04	✓	1,2,3	2 BNC F	ST/SMA	ST/FO/SC	✓	✓	✓	3/1.4	E-1
	2896		✓		1.54/2.04	✓	1,2,3	RJ45/BNC	ST/SMA	ST/FO/SC	✓	✓	✓	6/2.7	2Ch, T-1 or E-1
T-3/E-3/STS-1	2893		✓		44	✓	1,2,3	2 BNC F	ST	ST/FO/SC	✓	✓	✓	5/2.2	T-3
	2894		✓		34	✓	1,2,3	2 BNC F	ST	ST/FO/SC	✓	✓	✓	5/2.2	E-3
	2895		✓		51.8	✓	1,2,3	2 BNC F	ST	ST/FO/SC	✓	✓	✓	5/2.2	STS-1 (OC-1)
<b>LAN: Using RS-232/42/485 See sections applicable to these standards</b>															

\* Power Options: See "Power Options and How to Order" sheet (p. 106) for options and ordering instructions.

\*\* Pin outs are specified in data sheets

Temperature range 0 - 50 degrees C unless shown otherwise.

Extended Temperature (ET) range available on some products.

\*\*\* Distance: 2 km - STD, 5 km - L, 10 km - XL, 20 km - UL

### HOW TO ORDER

Base Model Number XXXX	Power* 1. 110 VAC - STD 2. 230 VAC - V 3. See Chart	Data Connector** M or F (F is STD on most models)	Distance** 2 Km - STD Other - Specify L, XL, or UL	Fiber and Connector		Temperature 0 - 50° C - STD -40 to +80° C - ET Other - Call S.I. Tech
				Multimode (MM)-STD	Singlemode (SM)-Specify	
				ST - STD	Other-Specify	
				Other-Specify	Other-Specify	

e.g. 2890V-2890T-1 To Fiber, 230VAC, RJ45, 2 Km, Multimode; ST Connectors, 0-50 degrees C

Specifications subject to change without notice.

ARCNET is a trademark of Datapoint Corp

IBM is a registered trademark of International Business Machines Corp

Omninet is a trademark of Corvus Systems Inc.

## LAN/WAN ETHERNET FIBER OPTIC BIT-DRIVERS®

### 2150 – 10/100A

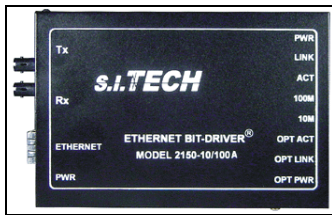

- Mini Optical Bit-Driver®
- Compatible with 10/100 Base-TX and 10 Base FL and 100 Base-FX networks
- Link Status, Optical, and Ethernet LED indicators
- Extends distance between Server or Switch and Hub
- Multimode is standard, Single mode optional
- Compatible with 2350-10/100A Card

### 2160\*

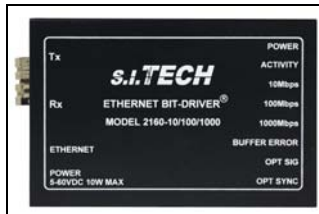

- Mini Optical Bit-Driver, 10/100/1000 Mbps Data Speed
- Link Status, optical and Ethernet LED Indicators
- Long Distances using Single mode Fiber
- Multimode or Single Mode

### 2350-10/100A\*



- Supports 10Base/100Base Tx and 10Base FL/100Base FX Standard
- Eurocard, 3001 Rack holds 12 Cards
- Power, Link Status, Activity and Collision LED Indicators
- ST or SC optical Connectors (ST, SC or FC Optional for Single Mode)
- Auto Senses Between 10 and 100 Mbps
- Plug and Play, No Setup required
- Compatible with 2150-10/100A

### 2350



- Supports 10Base FL or FOIRL Standard
- Small Size, 300 Rack holds up to 16 Cards
- Link Status, Receive Data, Transmit Data and Power LED Indicators
- ST or SMA Optical Connectors
- Compatible with 2550 Mini

### 2361-10/100/1000\*

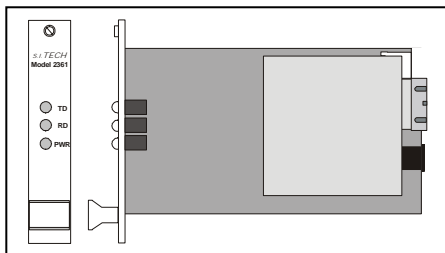

- Supports 10, 100, 1000 Mbps Data Speeds
- Eurocard, 3001 Rack holds 12 Cards
- Power, Link Status, Activity and Collision LED Indicators
- SC Optical Connectors
- Compatible with 2160-10/100/1000



## 2550



- ❑ Mini Optical Bit-Driver®
- ❑ Compatible with 10 Base-FL or FOIRL Standards
- ❑ Link Status, Receive Data, Transmit Data, and Power LED indicators
- ❑ Connects to RJ45 – Twisted Pair
- ❑ Multimode is standard (200, 50, 62.5), Single mode optional

## 2703\*

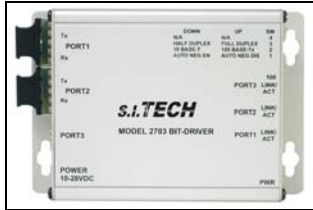

- ❑ Layer 2 switch meets IEEE 802.3
- ❑ Unmanaged 3 port (2 optical and 1 electrical) 10/100 Mbps switch
- ❑ Optical ports 1 and 2 – Various combinations: MM/MM, MM/SM
- ❑ Wire port 3 – 10 or 100 Base – T(x) wire as MDI – X
- ❑ Optic connector options: ST/SC/LC/MR-RJ
- ❑ Status indicators: PWR, Link/Activity, 10/100
- ❑ Switch for port 3 configuration

## 3150\*



- ❑ Highly shielded version of S.I.Tech #2150 – 10/100A Ethernet
- ❑ Designed for use in shield room, testing and instrumentation

## 3152\*



- ❑ Ethernet Optical Isolated Filter, 10/100 Mbps
- ❑ Designed for use in shield room/screen room testing, instrumentation
- ❑ Highly shielded

## 3160\*



- ❑ Highly shielded version of S.I.Tech #2160 – 10/100/1000 Ethernet
- ❑ Designed for use in shield room, testing and instrumentation

## 10 Mbps Ethernet Kit #2\*



- ❑ 2 - 2550 Ethernet Bit-Drivers
- ❑ 2 - 2121 Power Supplies
- ❑ 1 - 5202-010-8255 33' (10M) 2 Fiber Indoor Multimode Cable - ST/ST
- ❑ 1 - 7250 Straight Ethernet Cable
- ❑ 1 - 7251 Crossed Ethernet Cable

## 10/100Mbps Ethernet Kit #3\*



- ❑ 2 - 2150-10/100-A Ethernet Bit-Drivers
- ❑ 2 - 2164 Power Supplies
- ❑ 1 - 5202-010-8255 33' (10M) 2 Fiber Indoor Multimode Cable - ST/ST
- ❑ 1 - 7250 Straight Ethernet Cable
- ❑ 1 - 7251 Crossed Ethernet Cable

## 10/100/1000Mbps Ethernet Kit #12\*



- ❑ 2 - 2160-10/100/1000 Ethernet Bit-Drivers
- ❑ 2 - 2164 Power Supplies
- ❑ 1 - 5202-010-8264 33' (10M) 2 Fiber Indoor Multimode Cable - SC/SC
- ❑ 1 - 7250 Straight Ethernet Cable
- ❑ 1 - 7251 Crossed Ethernet Cable

## FIBER SIZE CONVERSION

S.I.Tech 2062 and 2082 can be factory configured to change one fiber size or optical fiber such as 200 micron to 62.5, 50 to 62.5 micron, or multimode to single mode. See ordering information table below.

Table 1: 2062 Combinations

Model Number	Description
2062-00 ST	1000 Micron Plastic Fiber to 50/62.5 Glass Fiber
2062-O-ST	OMRON 200 to 62.5 Micron – ST**
2062-ST*	Multimode 50/62.5 to Multimode 50/62.5 Repeater - ST
2062-MM/SM-ST	Multimode 50/62.5 to Single Mode Converter – ST
2062-SM/SM-ST	Single Mode to Single Mode Repeater - ST

\* If you need to go long distances 10km or more, use 1310nm TR/REC (designable as SM/SM)

\*\* Use with S.I.Tech #9402-0008-5568 fiber cable assembly

Table 2: Operating Distance for Fiber Optic Cable

Fiber Size Micron	Attenuation DB/km@				Distance							
					660nm		850nm		1300nm		1550nm	
	660nm	850nm	1310nm	1550nm	FT	Meters	FT	Meters	FT	Meters	FT	Meters
50	-	3.0	1.0	-	-	-	6600	2000	20000	6000	-	-
62.5	-	3.5	1.0	-	-	-	6600	2000	20000	6000	-	-
100	-	5.0	-	-	-	-	6600	2000	-	-	-	-
200	-	7.0	-	-	-	-	3300	1000	-	-	-	-
1000	200	-	-	-	330	100	-	-	-	-	-	-
10 SM*	-	-	0.35	0.25	-	-	-	-	33000	10000	66000	20000

\* Single mode (observe network timing restriction)

The 2062 and 2082 needs to be properly configured in order to be compatible with your system. For instance, if you are using:

- A. CISCO equipment with 850nm wavelength transmitter/receiver made for multimode fiber, then the S.I.Tech 2062 and 2082 port used with that CISCO equipment needs to be 850nm wavelength TR/REC. Similarly if remote end is 1300nm TR/REC then 2062 and 2082 port connecting to remote end should support 1300nm TR/REC.
- B. Typical Application – Fiber Size Conversion

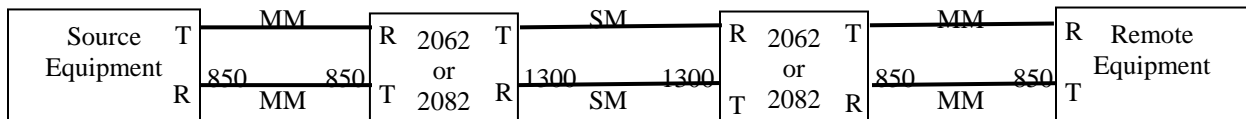

Note: Always Connect T to R and R to T as shown above.

S.I.Tech 2062 can be used up to 25Mbps as a repeater. If your data rate is higher such as 100 Mbps or Gigabit (1000 Mbps), use S.I.Tech #2082

Table 3: 2082 Combinations  
Ordering Information

Model Number	Description
2082-MM/MM-100	Multimode 50/62.5 to Multimode 50/62.5 Repeater for up to 100Mbps. ST Standard, SC option
2082-MM/MM-1000	Multimode 50/62.5 to Multimode 50/62.5 Repeater for Gigabit. SC standard
2082-MM/SM-100	Multimode 50/62.5 to Single mode converter for up to 100 Mbps. ST or SC to SC
2082-MM/SM-1000	Multimode 50/62.5 to Single mode converter for up to Gigabit. SC to SC
2082-SM/SM-100	Single mode to Single mode Repeater for up to 100 Mbps. SC to SC
2082-SM/SM-1000	Single mode to Single mode Repeater for up to Gigabit. SC to SC

**Notes:**

1. Single mode (1300nm) is supplied with SC connectors as standard (FC optional).
2. **Check fiber bandwidth spec to determine length limitation.**
3. Check link loss (attenuation).
4. Single fiber option.
5. For proper operation 2082 fiber size converter should be matched to customer equipment e.g. If your Transmitter/Receiver is 850nm, S.I.Tech 2082 TR/REC should be 850nm. For 1300nm use 1300nm rated 2082.

Table 4: Operating Distance for Fiber Optical Cable and 2082

Fiber Size (Micron)	Attenuation (db/Km)			Distance-100Mbps (Meters)			Distance-1000Mbps (Meters)			Distance – 100 Mbps (Feet)			Distance – 1000 Mbps (Feet)		
	Wavelength(nm)			Wavelength(nm)			Wavelength(nm)			Wavelength(nm)			Wavelength(nm)		
	850	1300	1550	850	1300	1550	850	1300	1550	850	1300	1550	850	1300	1550
50	3.0	1.0	-	2000	6000	-	550	600	-	6600	20000	-	1600	2000	-
62.5	4.0	1.0	-	2000	6000	-	200	600	-	6600	20000	-	600	2000	-
10*	-	0.35	0.25	-	10000	12000	-	20000	25000	-	33000	40000	-	66000	82500

\* Single mode option (for long distance, higher power, contact factory.)

At Gigabit data rate both attenuation and bandwidth of the fiber should be considered to determine distance.

## LAN/WAN FIBER OPTIC REPEATER BIT-DRIVERS® (FIBER SIZE CONVERTER)

### 2062

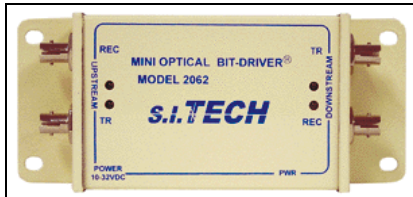

- Fiber Optic Repeater
- Can be configured to convert Multimode to Single mode
- Extends Distance of Multimode or Single mode Segment
- Max Data Rate is 25 Mbps
- ST connector is standard

### 2082



- Fiber Optic Repeater
- Can be configured to convert Multimode to Single mode
- Extends Distance of Multimode or Single mode Segment
- Max Data Rate is 1000 Mbps (Gigabit)
- ST connector is standard, SC/FC Optional, ST (100 Mbps)

## LAN/WAN ARCNET FIBER OPTIC BIT-DRIVERS®

### 2353

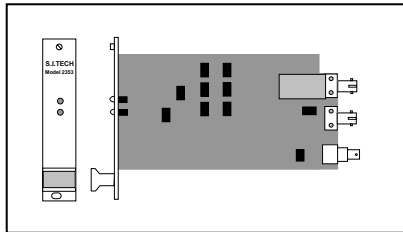

- ❑ Card Cage Mounted Fiber Optic Bit-Driver® supporting ARCNET protocol
- ❑ Max Data Rate is 2.5 Mbps
- ❑ Extends distance of ARCNET based 93 Ohm coax networks
- ❑ Series 3000 Rack holds 16 cards

### 2853



- ❑ Synchronous Simplex or Full Duplex Optical Bit-Driver®
- ❑ Max Data Rate is 2.5 Mbps
- ❑ Extends distance of ARCNET based 93 Ohm coax networks
- ❑ Multimode is standard, Single mode optional

### 9024



- ❑ Passive Optical Star
- ❑ Allows for totally optical ARCNET network
- ❑ 4 to 24 Ports
- ❑ Use in conjunction with 2353 and 2853 Bit-Drivers®

Note: ARCNET is a trademark of Datapoint Corporation

## WIDE AREA NETWORKS (WAN)

### 1. Special Application Using Wave Length Division Multiplexing (WDM):

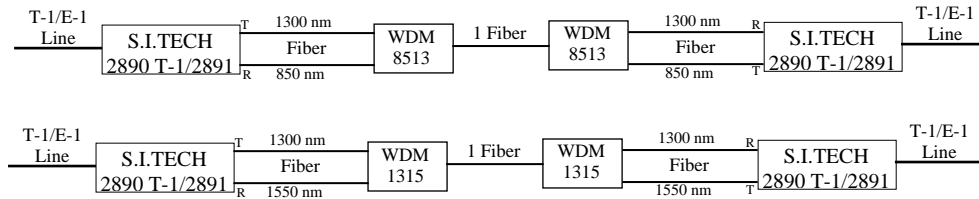

### 2. Dedicated T-1/E-1 Line with Phone Network:

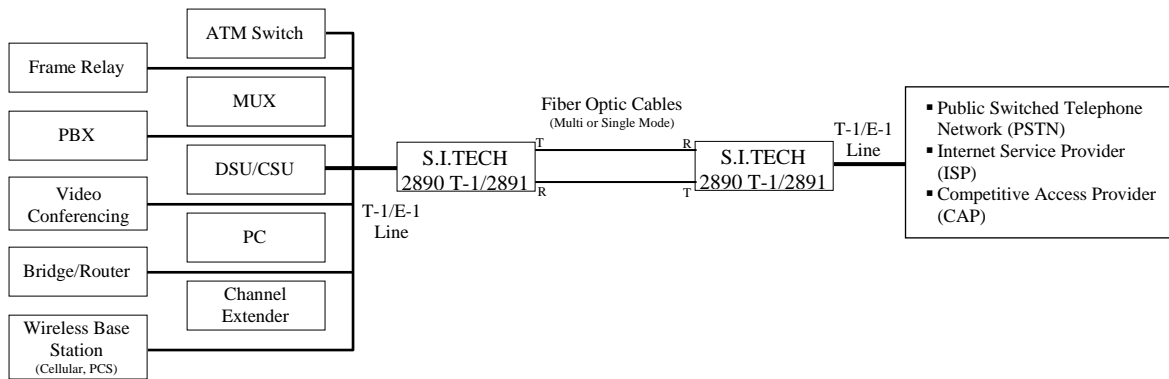

### 3. Local Area (Wide Area) Network Using T-1/E-1 Fiber Line:

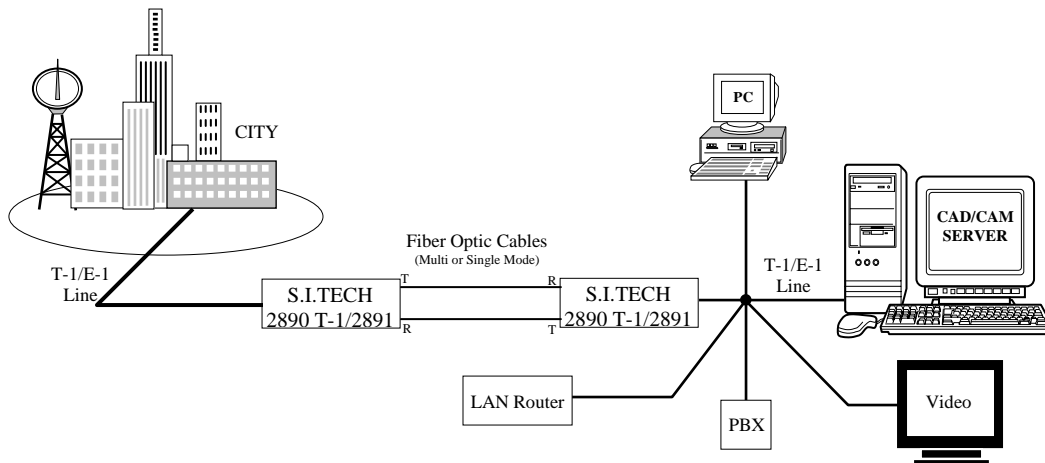

### 4. T-3/E-3 or STS-1 (OC-1) Applications:

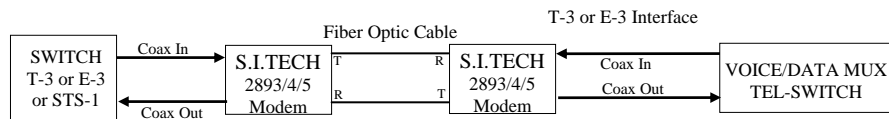

## WAN FIBER OPTIC BIT-DRIVERS®

### 2390\*

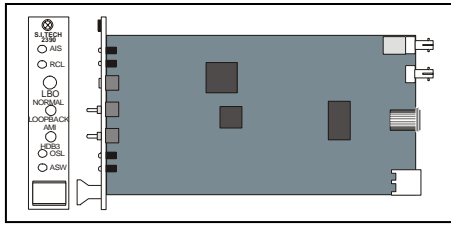

- T1 – AMI or B8ZS Card Eurocard Size
- Status indicators and alarms for ease of use
- Twisted pair T1 Interface (RJ45)
- AMI or Zero Suppression Line Codes
- Multimode and Single mode Fiber
- Toggle Switches for Control Settings and Rotary Switch for T1 Line Build out
- Up to 10Km at Low Cost
- 3001 rack holds 12 Cards

### 2391\*

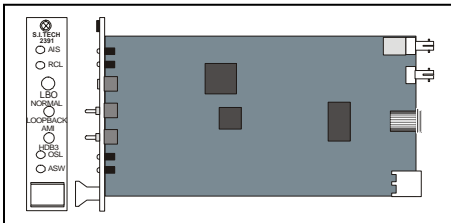

- E1 – AMI or HDB3 Card Eurocard Size
- Status indicators and alarms for ease of use
- BNC E1 Electrical Interface
- AMI or Zero Suppression Line Codes
- Multimode and Single mode Fiber
- Toggle Switches for Control Settings and Rotary Switch for E1 Line Build out
- Up to 10Km at Low Cost
- 3001 rack holds 12 Cards

### 2890



- Synchronous Half or Full Duplex Optical Bit-Driver®
- T1 – AMI or B8ZS Line Coding
- Clear Channel Capability
- Status indicators and alarms for ease of use and maintenance
- Max Data Rate is 1.544 Mbps
- Stand Alone or Rack Mount Options
- Multimode is standard, Single mode optional
- 110VAC/230VAC/48VDC Options
- Interfaces with either ST, SC, or FC connectors
- 2 Channel T-1 Model #2890-2R or 2896

### 2890-2R-ASP-1



- 2 T1 Independent Channels
- Status indicators
- Power
- Multimode is standard, Single mode optional
- ST
- Designed for Military systems
- Ruggedized Vibration Immunity
- Conformal Coated(s) for Environmental Protection

### 2890-4R-ASP-1\*



- 4 CH Independent T1, AMI or B8ZS
- Status indicators and Alarms
- Multimode and Single mode
- Up to 10 Km at low cost
- Channels pairs 1 or 2, 3 and 4 can be operated in redundant fiber mode

## 2891



- Synchronous Half or Full Duplex Optical Bit-Driver®
- E1 – AMI or HDB3 Line Coding
- Clear Channel Capability
- Status indicators and alarms for ease of use and maintenance
- Max Data Rate is 2.048 Mbps
- Stand Alone or Rack Mount Options
- Multimode is standard, Single mode optional
- 110VAC/230VAC/48VDC Options
- Interfaces with either ST, SC, or FC connectors
- 2 Channel E-1 Model #2891-2R

## 2893



- Synchronous Half or Full Duplex Optical Bit-Driver®
- T-3 Model #2893, 2 Channel T-3 Model #2893-2R
- Status indicators and alarms for ease of use and maintenance
- Max Data Rate is 44.736 Mbps
- 1U High Rack Mounted
- Multimode is standard, Single mode optional
- 110VAC/230VAC/48VDC Options
- Interfaces with either ST, SC, or FC connectors

## 2894



- Synchronous Half or Full Duplex Optical Bit-Driver®
- E-3 Model #2894, 2 Channel E-3 Model #2894-2R
- Status indicators and alarms for ease of use and maintenance
- Max Data Rate is 34.368 Mbps
- 1U High Rack Mounted
- Multimode is standard, Single mode optional
- 110VAC/230VAC/48VDC Options
- Interfaces with either ST, SC, or FC connectors

## 2895



- Synchronous Half or Full Duplex Optical Bit-Driver®
- STS-1 Model #2895, 2 Channel STS-1 Model #2895-2R
- Status indicators and alarms for ease of use and maintenance
- Max Data Rate is 51.84 Mbps
- 1U High Rack Mounted
- Multimode is standard, Single mode optional
- 110VAC/230VAC/48VDC Options
- Interfaces with either ST, SC, or FC connectors

## 2896\*



- 2CH Independent T1 (DS1), AMI or B8ZS
- Provides Clear Channel Capability
- Status Indicators and Alarms for easy of Use
- Multimode is standard, Single mode optional
- Up to 10Km at Low Cost
- Optical Link Failure Alarm Build in
- Can be used as Redundant T1 CH with Automatic Switch over



## **IBM PRODUCTS**

## IBM PRODUCTS

### 1. IBM 3X/AS 400/AS 400E:

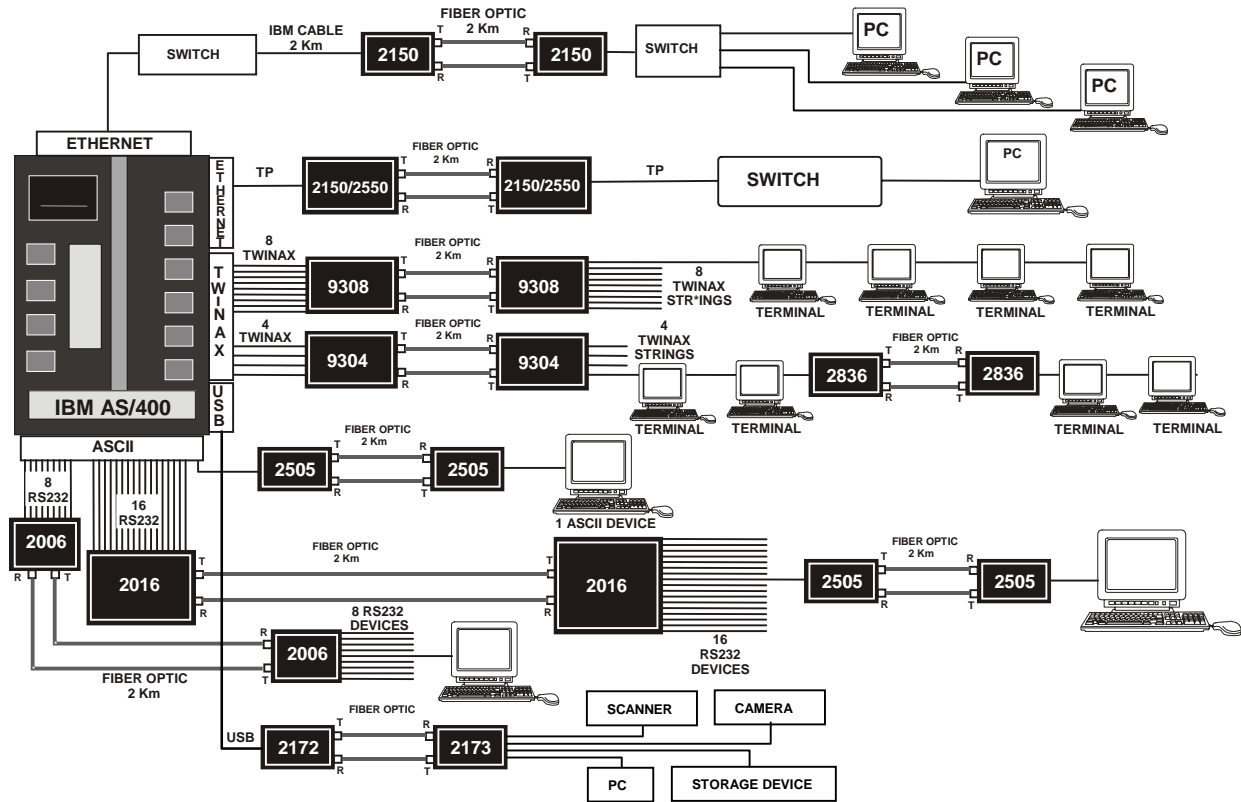

### 2. IBM RISC/6000:

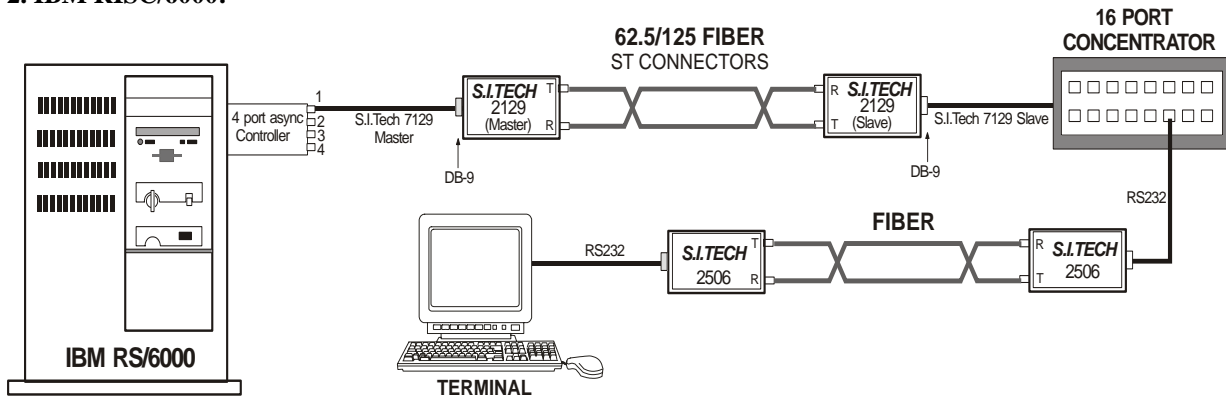

## 4. IBM Mainframe:

### IBM MAINFRAME

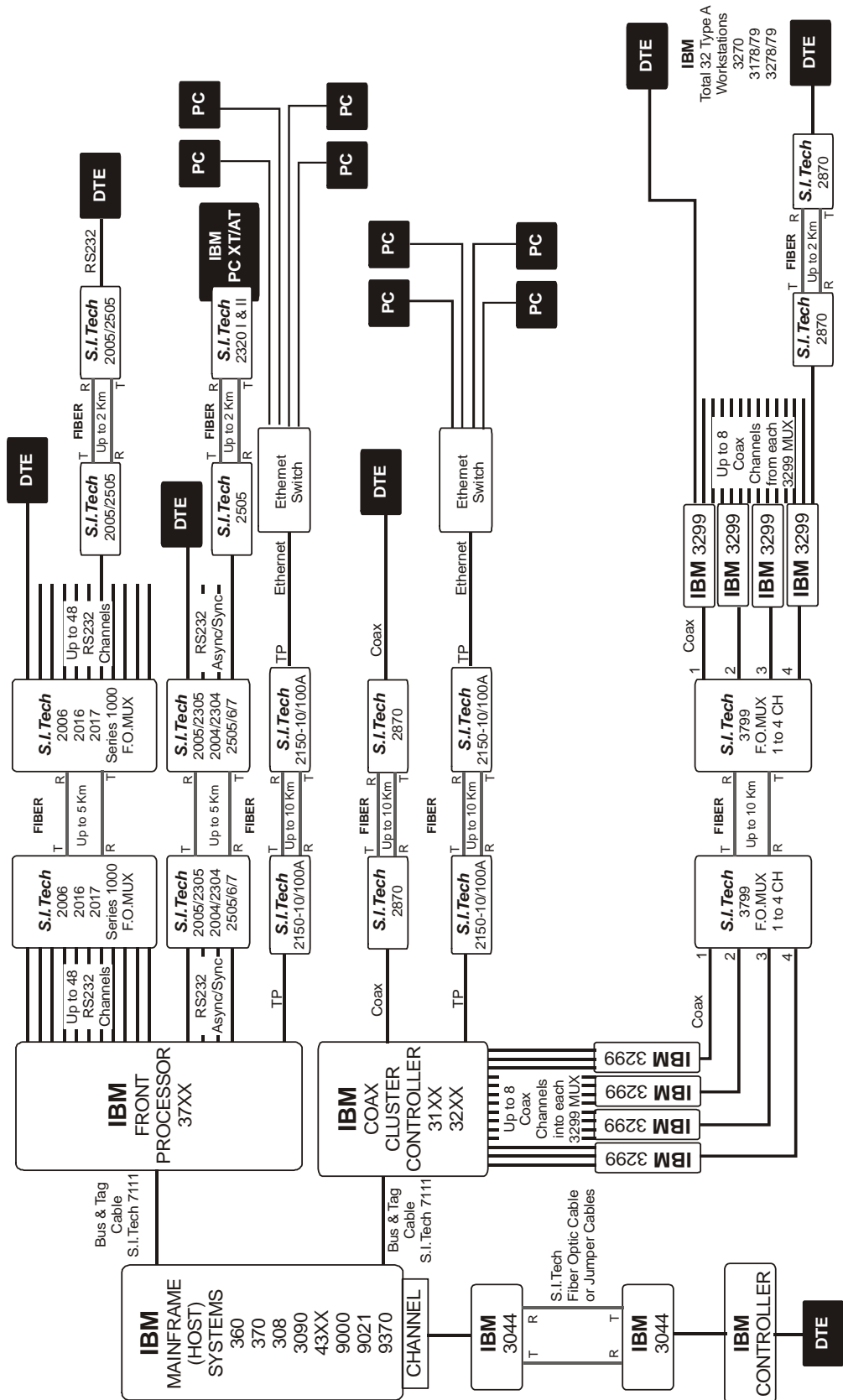

## IBM

IBM occupies a unique position in the computer industry being the world's largest computer system manufacturer. The world's largest corporations, governments, and educational institutions use IBM systems, particularly large and medium scale systems. Due to the massive size of these systems, long distance data communication and distributed data communication is a must. Fiber Optics is the most logical choice for these applications.

## IBM

### 308/370/3090/43XX/9000/9021/9370 MAINFRAME NETWORKS SNA

IBM mainframe systems are now used as servers for large data networks and storage networks. SNA – System Network Architecture: Basically a tree structure network to interconnect various IBM data processing equipment. It is also called Hierarchical Network. See Diagram below:

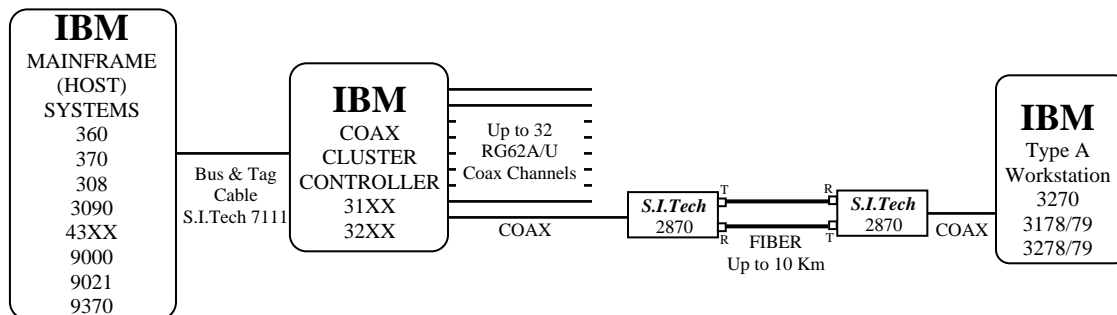

## IBM MIDRANGE SYSTEMS

IBM Midrange Systems are typically designed for small to midsize corporations that do not require large systems, such as IBM mainframe. In today's environment Midrange systems support a small number of users to several thousand users. IBM Systems in this category are system 3X, AS/400, AS/400E, and RISC/6000

## IBM PC AND NETWORKING

IBM PC (LENOVO) and Networking – IBM popularized Token Ring Network and Personal Computers. Most IBM systems today support Token Ring as well as other Networks, such as Ethernet, Arcnet, FDDI and other protocols such as; RS-232, RS-422, RS-485, USB, V.35 and so on. S.I. Tech makes Fiber Optic products to support most of the communications protocols and many networking products. These are covered in the appropriate section of this Catalog. Only IBM specific products are covered in the IBM section.

Note: IBM is a registered trademark of International Business Machines Corporation  
SNA, AS/400, AS/400E, and RISC/6000 are trademarks of International Business Machines Corporation

**TABLE M  
IBM SYSTEMS**

SYSTEM	Model #	Package		Channel Data Rate Kbps	Number of Channels	Power* Option	Data Connection	Fiber * Connection Multimode 820 nm	Fiber Connection Singlemode 1300 nm	Distance Km ***		Weight LB/KG	Remarks
		Stand Alone	Mini Rack							2	5		
<b>Mainframe 370/390/3270 SNA Networks</b>													
	2370		√	2.35	1	1,2	BNC	ST/SMA	ST/SC/FC	√	√	1/4	
	2870	√		2.35	1	1,2	BNC	ST/SMA	ST/SC/FC	√	√	3/1.4	
	3799	√		2.35	4	1,2	BNC	ST/SMA	ST/SC/FC	√	√	4.4/2	
<b>Midrange Systems 3X/AS-400/AS-400E</b>													
	2336		√	1.0	1	1,2	RJ45	ST/SMA	ST/SC/FC	√	√	1/4	
	2836	√	√	1.0	1	1,2	Twinax	ST/SMA	ST/SC/FC	√	√	3/1.4	
	9036		√	1.0	1 TO 7	1,2	RJ45	ST/SMA	ST/SC/FC	√	√	6.5/3	
	9302	√	√	1.0	2	1,2	Twinax	ST/SMA	ST/SC/FC	√	√	4/1.8	
	9304	√	√	1.0	4	1,2	Twinax	ST/SMA	ST/SC/FC	√	√	12/6.5	
	9308	√	√	1.0	8	1,2	Twinax	ST/SMA	ST/SC/FC	√	√	12/5.5	
<b>RS/6000****</b>													
	2129		√	1.2	1	6	DB9 F	ST/SMA	ST	√	√	.28/13	for 128 port HUB
<b>LAN/WAN - See LAN/WAN Section</b>													
<b>ASCII - See RS-232/422/485 Section</b>													

\* Power Options: See "Power Options and How to Order" sheet p. 106 for options and ordering instructions.

\*\*TW/RJ45/DB9

\*\*\*Check IBM Timing Specifications

\*\*\*\* 2129 uses M&S 7129 cables.

**HOW TO ORDER**

Base Model Number	Power*	Distance***	Fiber and Connector		
			Multimode (MM) - STD	Singlemode (SM) - Specify	Temperature
XXXX	1. 110 VAC - STD 2. 230 VAC - V 6. See Power Supply Chart	2 Km - STD Other - Specify L	ST - STD Other - Specify	ST - STD Other - Specify	0 - 50° C - STD

IBM, SNA, AS/400, RS/6000 are trademarks of International Business Machines

e.g. 2836 = 1 part Twinax to Fiber Bit-Driver, Standalone, 110VAC, ST Connector



## IBM TWINAX TO FIBER OPTIC BIT-DRIVERS® (IBM AS/400, AS/400E, & S3/X)

2336

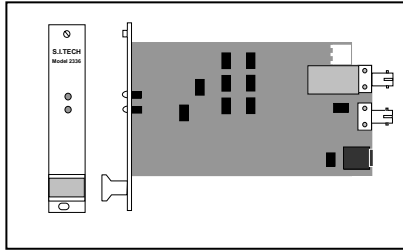

- ❑ Card Cage Mounted Fiber Optic Bit-Driver®
- ❑ Synchronous Half or Full Duplex Optical Bit-Driver®
- ❑ Compatible with IBM 3/X and AS/400 systems
- ❑ Power, Transmit Data, and Receive Data LED status indicators
- ❑ Supports 1 RJ11 Connector
- ❑ Max Data Rate is 1 Mbps
- ❑ Fits Series 3000 Card Cage
- ❑ Multimode or Single mode

2836

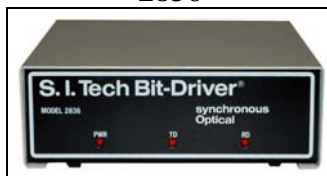

- ❑ Synchronous Half or Full Duplex Optical Bit-Driver®
- ❑ Compatible with IBM 3/X, AS/400, and AS/400E systems
- ❑ Power, Transmit Data, and Receive Data LED status indicators
- ❑ Supports 1 Twinax Port
- ❑ Works with 9036 Hub to support 7 user terminals
- ❑ Max Data Rate is 1 Mbps
- ❑ Multimode is standard, Single mode optional

9036



- ❑ Synchronous Half or Full Duplex Fiber Cluster® Hub
- ❑ Compatible with IBM 3/X and AS/400 systems
- ❑ Fully Compatible with 2836 Bit-Driver®
- ❑ Max Data Rate is 1 Mbps
- ❑ Allows direct connect RJ45 Twisted Pair – 7 Users
- ❑ Multimode is standard, Single mode optional

9302



- ❑ Two Channel Synchronous Half or Full Duplex Multiplexer Optical Bit-Driver®
- ❑ Compatible with IBM 3/X, AS/400, and AS/400E systems
- ❑ Power, Transmit Data, and Receive Data LED status indicators
- ❑ Max Data Rate is 1 Mbps per Twinax Port
- ❑ Multimode is standard, Single mode optional
- ❑ Supports up to 14 Users

9304



- ❑ Four Channel Synchronous Half or Full Duplex Multiplexer Optical Bit-Driver®
- ❑ Compatible with IBM 3/X, AS/400, and AS/400E systems
- ❑ Power, Sync, Transmit Data, and Receive Data LED status indicators
- ❑ Stand Alone or Rack Mount Options
- ❑ Rack can hold 2 units side by side
- ❑ Max Data Rate is 1 Mbps per Twinax Port
- ❑ Multimode is standard, Single mode optional
- ❑ Supports up to 28 Users

## 9308



- ❑ Eight Channel Synchronous Half or Full Duplex Multiplexer Optical Bit-Driver®
- ❑ Compatible with IBM 3/X and AS/400 systems
- ❑ Power, Sync, Transmit Data, and Receive Data LED status indicators
- ❑ Stand Alone and Rack Mount Options
- ❑ Rack can hold 2 units side by side
- ❑ Max Data Rate is 1 Mbps per Twinax Port
- ❑ Supports up to 40 Users

Note: Most IBM systems support Ethernet LAN, see LAN section for appropriate product for your application.

## IBM

### 3270 COAX TO FIBER OPTIC BIT-DRIVERS® (IBM Systems 370/390 and SNA Networks)

## 2370



- ❑ Card Cage Mounted Synchronous Simplex or Full Duplex Fiber Optic Bit-Driver®
- ❑ Fully Compatible with IBM SNA Networks
- ❑ Max Data Rate is 2.35 Mbps
- ❑ Coax (93 Ohm) BNC Connector is standard
- ❑ Series 3000 Card Cage holds 16 Cards
- ❑ Multimode or Single mode

## 2870



- ❑ Synchronous Simplex or Full Duplex Fiber Optic Bit-Driver®
- ❑ Fully Compatible with IBM SNA Networks
- ❑ Max Data Rate is 2.35 Mbps
- ❑ Coax (93 Ohm) BNC Connector is standard
- ❑ Multimode is Standard, Single mode Optional

## 3799



- ❑ Four Channel Synchronous Simplex or Full Duplex Multiplexer Optical Bit-Driver®
- ❑ Compatible with IBM Mainframe Computers, 3174, 3274 and other controllers, and 3299 multiplexers
- ❑ Fully Compatible with IBM SNA Networks and 3270 Systems
- ❑ Max Data Rate is 2.35 Mbps per channel
- ❑ Multimode or Single mode

## IBM FIBER OPTIC BIT-DRIVERS® FOR IBM RS/6000

2129



- Mini Synchronous Half or Full Duplex Optical Bit-Driver®
- Compatible with IBM RS/6000 servers and IBM RANS – 128 Users
- Point to Point Links up to 2.5 Km. Each Link consists of one 2129 “master” and one 2129 “slave” Bit-Driver
- Units require S.I. Tech #7129 master/slave cables
- Master or Slave Switch Selectable
- RS-485, 9 wire port operating at 1.2 Mbps
- Receive Data, Transmit Data, Master, and Slave LED Indicators
- RS-485 IBM RS/6000 Protocol
- Multimode or Single mode

Note: Most IBM systems support Ethernet LAN, See LAN section for appropriate product for your application.



**SIGNAL DISTRIBUTION SYSTEMS**

## SIGNAL DISTRIBUTION SYSTEMS

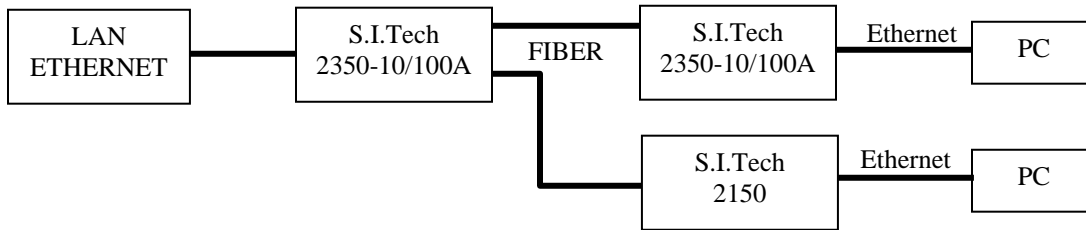
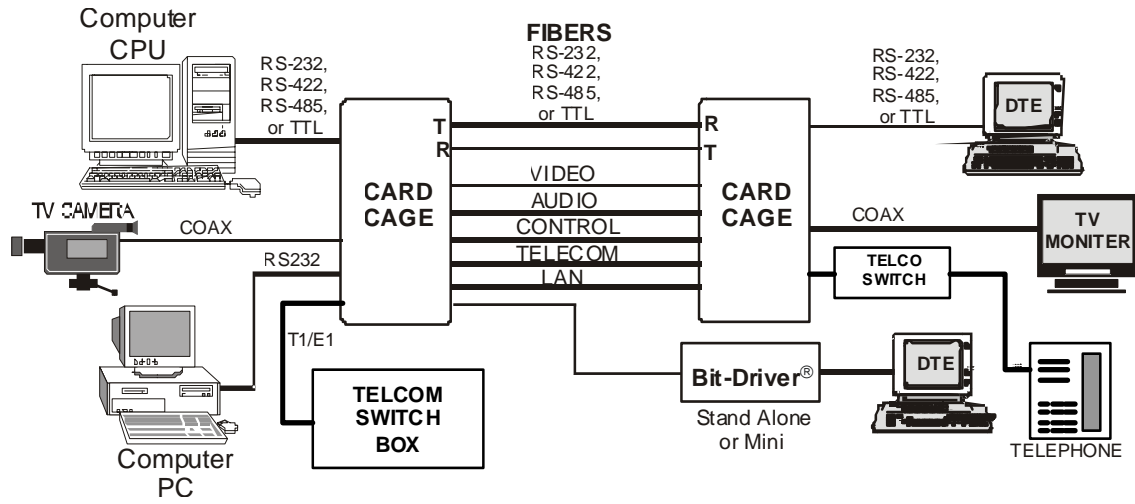

## SIGNAL DISTRIBUTION SYSTEMS

### SERIES 1000 NON-MUXED



- ❑ Card cage to mount in standard 19 inch rack to support various Bit-Driver® products
- ❑ Designed to hold up to 12 Eurocard size interface cards plus 2 power supply cards
- ❑ Supports Video, Analog, TTL, RS232, RS422, and MIL-188-114 Bit-Drivers®. See individual categories for card details
- ❑ Overall height 7 inches, overall depth 15 inches
- ❑ Configuration is Point to Point
- ❑ 110 VAC or 230 VAC Input Power

### SERIES 3000

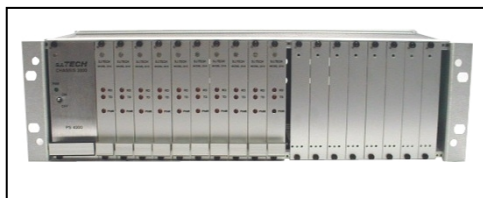

- ❑ Card cage to mount in standard 19 inch rack to support various Bit-Driver® products
- ❑ Model 3000 A is 9 inches deep and 4.5 inches tall to accommodate up to 16 Eurocard size cards plus 2 power supplies
- ❑ Model 3000 B is 12 inches deep and 4.5 inches tall to accommodate up to 16 American Standard Size cards plus 2 power supplies
- ❑ Supports RS232, RS422, RS485, Video, and several proprietary configuration Bit-Drivers®. See individual categories for card details – Point to Point Configuration
- ❑ 110 VAC or 230 VAC Input Power

### MODEL 3001\*

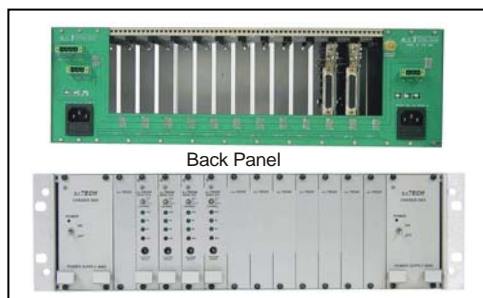

- ❑ Card cage to mount in standard 19" rack to support various Bit driver products such as RS232/T1/E1/Ethernet/Video various power supplies.
- ❑ 3001 rack holds a total of 12 Eurocard size cards with 1 or 2 power supplies. Cards can be mix or match.
- ❑ All connectors on back of rack for easy access
- ❑ Power supply with alarm for failure
- ❑ Power – 110/230VAC or 48VDC

### MODEL 3000 AESFOT\*

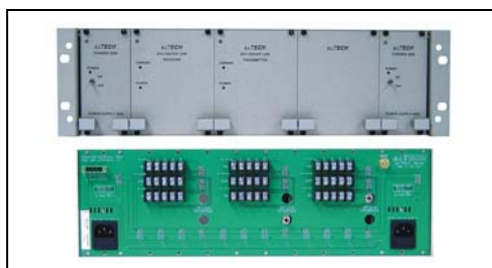

- ❑ The model 3000 AESFOT card cage is special designed to allow the use of fiber optics for ON/OFF control in a rack. Each individual Bit-Driver card is fully compatible with stand-alone Bit-Drivers.
- ❑ 2311 – ON/OFF Link Transmitter
- ❑ 2312 – ON/OFF Link Receiver

## FIBER CLUSTER®

9024

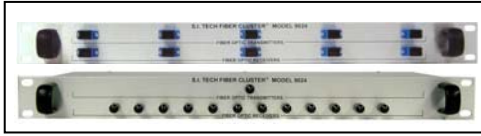

- ❑ 4 to 24 Port Passive Optical Star to distribute signals up to 24 workstations
- ❑ Totally Passive Optical Network
- ❑ 19" Rack Mountable
- ❑ Bi-directional or unidirectional

**ACCESSORIES**

## ACCESSORIES CABLE ASSEMBLIES

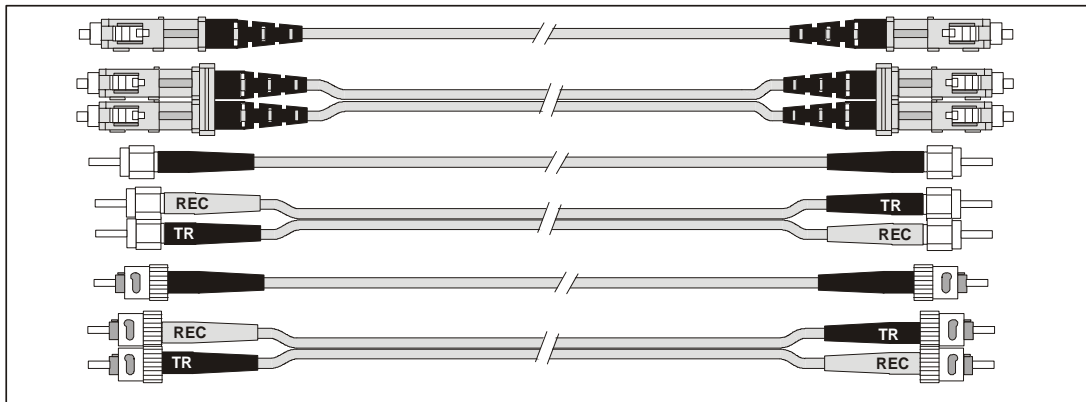

S.I.Tech Fiber Optic Cable Assemblies are precision made to customer specifications or S.I.Tech specifications. Each assembly is tested for attenuation, serialized, and individually packed.

### FIBER OPTIC CABLE ASSEMBLIES

S.I.Tech Cable Number	Fiber Type	Fiber Size Microns	Number of Fibers	Attenuation dB/Km 850nm-MM 1300nm-SM	Cable Type	Breakout Kit	Connector
5201	Multimode	62.5	1	4	Indoor	No	Specify
5202	Multimode	62.5	2	4	Indoor	No	Specify
6002	Multimode	62.5	2	3	Outdoor	Yes	Specify
7201	Multimode	50	1	3	Indoor	No	Specify
7202	Multimode	50/62.5	2	3	Indoor/R*	No	Specify
8201	Singlemode	8	1	1	Indoor	No	Specify
8202	Singlemode	8	2	1	Indoor	No	Specify
9201	Plastic	1000	1	250	Indoor	No	Specify
9202	Plastic	1000	2	250	Indoor	No	Specify

### CONNECTOR TYPES

Installed Part Number	Type
8252	SMA
8255	ST
8261	FC
8263	FDDI
8264	SC
8265	MT to RJ
8266	LC

#### Cable Assembly Part Number Scheme:

XXXX-XXXX-XXXX-XXXX  
1 5 9 13

Digits 1, 2, 3, 4 - Specifies Cable Type  
 Digits 5, 6, 7, 8 - Indicates Length ft. (3 digits for meters)  
 Digits 9, 10, 11, 12 - Connector to use  
 Digits 13, 14, 15, 16 - Other Requirements

e.g. 1) 10 meters (33 ft.) assembly, 2F, 62.5/125, ST to ST = 5202 - 0033 - 8255  
 2) Same as 1) expect SMA on one end & ST on the other end = 5202 - 0033 - 5255

Note: Please specify if a particular connector and/or cable manufacturer is required.  
 Cable types such as Plenum, Outdoor, Aerial, Burial, etc. are available upon request.

*Specifications subject to change without notice.*

#### Typical standard cables and part numbers:

5201 - 0010 (3m) - 8255 - 10 ft. jumper, 62.5, ST to ST.  
 5202 - 0010 - 8255 - 2F, 10 ft, 62.5μ, ST to ST.  
 7202 - 0100 - 8252 - 2F, 62.5 μ, 100 ft, SMA to SMA(R\*).  
 7201 - 0005 - 8255 - 1F, 50 μ, 5 ft, ST to ST.

\* R-Ruggedized

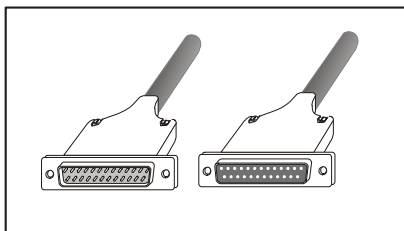
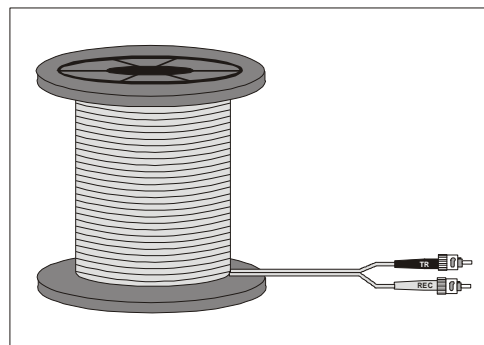

- ❑ S.I. Tech can suggest and supply bulk cables, both fiber and metallic, for use with all Bit-Drivers
- ❑ RS-232/422/485/V.35 data cable assemblies with male or female DB-9, DB-15, DB-25, DB-37, DB-50 or V.35 are custom made for specific applications
- ❑ Video/Audio/Data Cable assemblies available.
- ❑ Shielded and unshielded connectors are available

## ACCESSORIES

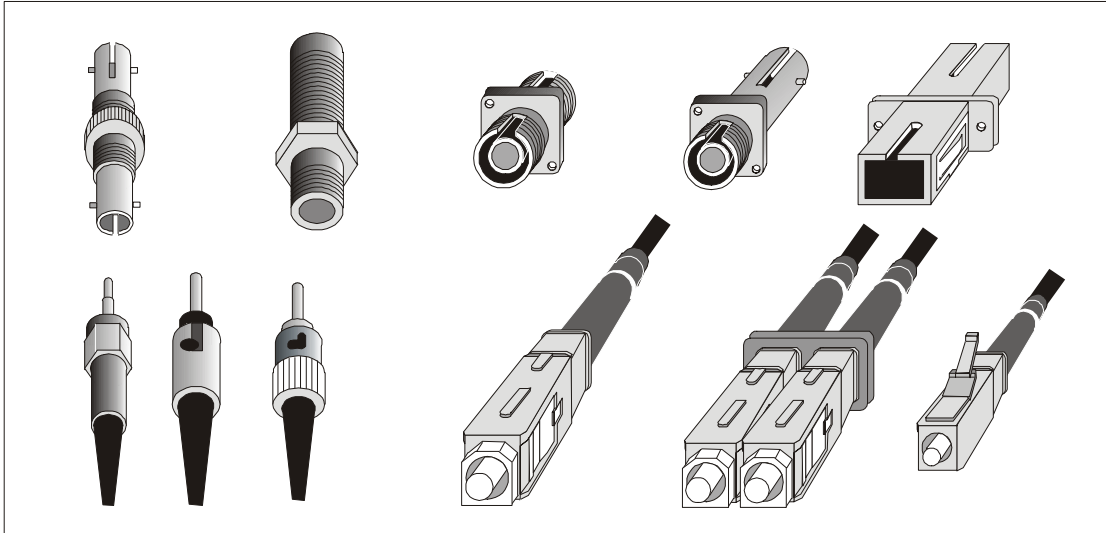

S.I.Tech stocks high quality accessories to support your fiber optic system requirements. If you need a specific part that is not listed below, contact S.I.Tech.

### Fiber Optic Couplers

- 8075 Simplex
- 8076 SMA
- 8077 ST
- 8078 SC
- 8079 FC
- 8080 LC

### Fiber Optic Adapters

- 8888 SMA to ST\*
- 8889 ST to SC\*
- Other\*
- 5561 Male ST/Female FC
- 5564 Male ST/Female SC
- 6455 Male SC/Female ST
- 6466 SC to LC

\* 1 meter cable assemblies

### Test Equipment

- Power Meter\*
- Power Source\*
- OTDR\*

\* Call S.I.Tech

### Fiber Optic Connectors

- 8052 SMA
- 8055 ST
- 8061 FC
- 8063 FDDI
- 8064 SC
- 8065 MT to RJ
- 8066 LC

### Termination Kits

- SMA\*
- ST\*
- SC\*

\* Call S.I.Tech

*Specifications subject to change without notice.*





**WDM  
WAVE DIVISION MULTIPLEXERS/DEMULTIPLEXERS  
AND OPTICAL SPLITTERS**

## WDM (WAVE DIVISION MULTIPLEXERS/DEMULTIPLEXERS)

#8513 (850/1300)\*  
 #1315 (1310/1550)\*  
 #9951 (980/1550)\*

- ❑ WDM allows combining of 2 or more optical wavelength signals on the same fiber for transmission. Useful when there are limited number of fibers available
- ❑ Extremely useful for very long distance transmission to reduce cost of cabling and significantly increase the amount of data transmission
- ❑ Light Duty WDM, Single Mode designed to meet Bellcore GR 1209 & 1221

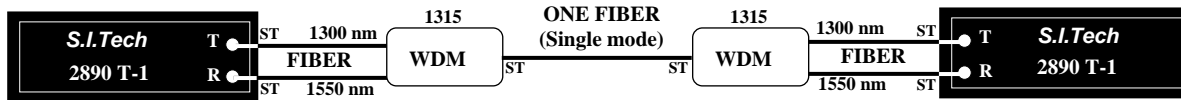
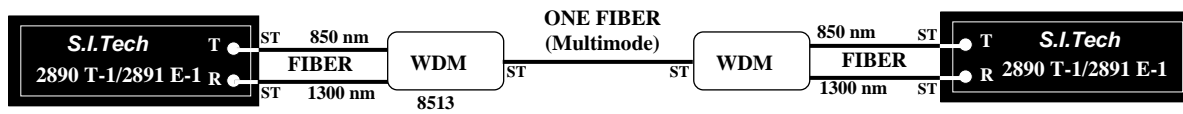

### OPTICAL SPLITTER

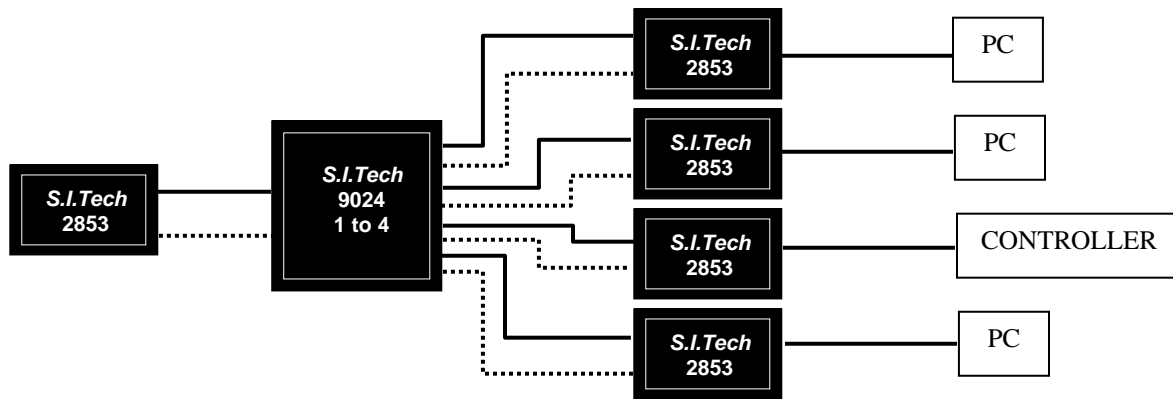

Optical splitters with various combinations such as 1 to 2/1 to 3/1 to 4/1 to 24 are available for use in applications where optical isolation is required and 1 way or 2 way controller communication takes place.

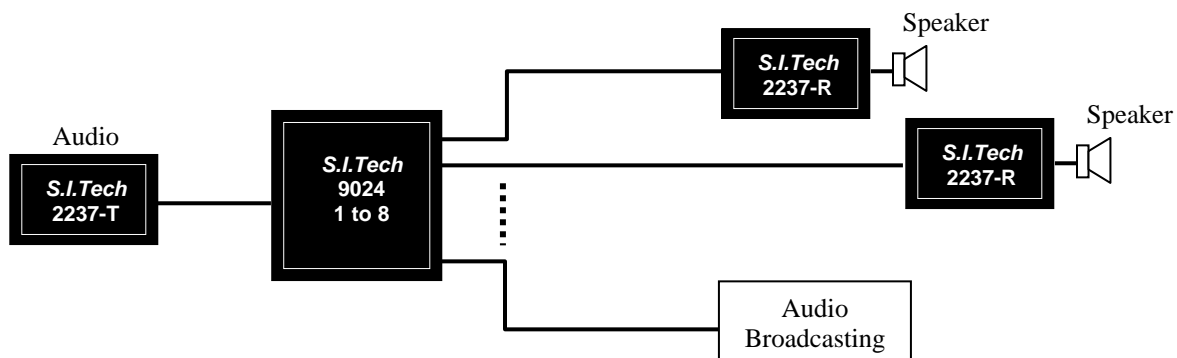

## BIT-DRIVER® PACKAGING

**Packaging:** S.I. Tech products are available in various sizes and shapes. We offer fiber optic products for most any application.

**Mini Bit-Drivers:** As the name implies these are miniature units typically 1.75W X 3.0L X 0.625D inches (4.5 X 7.5 X 1.6 cm) in metal enclosures.

These are also the lightest weight units (approx. 100 grams or 0.25 lbs.). These products are made using the latest surface mount components.

Size is such that the unit can be directly mounted to a serial port of a computer. For this purpose most products are offered with male or female type connector options. If the computer has a male connector, purchase a female type connector from S.I. Tech. This way you do not need an RS-232 cable assembly, eliminating clutter behind the PC. A cable can pick up electrical noise so it is best to eliminate it or keep it as short as possible. Typical mini units (exception – host powered unit) require an external power supply. (Host power: Bit-Driver draws power from the computer to which it is attached.)

**External Power Supplies:** Depending upon the application, several models are offered. Refer to the section on Power Options and How to Order.

**Stand Alone Bit-Driver:** These products are designed to be used as table top versions or shelf mounted units. Typically 7.5W X 7.0L X 3.0H inches (19 X 17.8 X 7.6 cm) size industrial strength metal case. Power supply is built into these units and some come with board attached power cord and some with detachable power cords. The units offer various power options – with the most common being 110 VAC or 230 VAC input. Products are UL/CE/FCC approved and listed where required.

Power cord used is a 3 prong with ground connection, international (IEC) rated.

**Card and 19” Rack:** S.I.Tech makes a Eurocard size card for many of the products. Typical 19” card cage holds 12 or 16 cards with 1 or 2 power supply. There is a provision for a redundant power supply where required. 110 VAC/230 VAC/DC power options are available with products being UL/CE/FCC approved.

**Multiplexers:** All multiplexer products are in industrial strength metal cases and available as stand-alone or 19” rack mounted units at no additional cost to the customer. 110 VAC/230 VAC/DC power options are available with products being UL/CE/FCC approved.

**Tempest:** S.I.Tech supplies modems and multiplexers certified to Tempest specifications for secure communication applications. These products are available for shield room applications.

**Din Rail Mounting:** Option is available on many products for mounting on Din Rail.

**F.O. Filters:** Specialized packaging and designs are available for custom applications. Typical filters are isolated using multimode fibers and two interface boards such as Ethernet.

**Ruggedized/Industrial:** Enclosures are available for outdoor and heavy duty industrial applications.

## POWER OPTIONS AND HOW TO ORDER

Follow instructions in parenthesis at the end of each option when creating model number to order.

- |                                   |  |
|-----------------------------------|--|
| 1. 110VAC                         | (STD - Do not add to Base Model Number)  |
| 2. 230VAC                         | (Add "V" to Base Model Number)   |
| 3. -48VDC                         | (STD -Do not add to Base Model Number)   |
| 4. +12VDC                         | (STD - Do not add to Base Model Number)  |
| 5. External Power Supply          | S.I. Tech #2101, 110VAC or S.I. Tech #2102<br>230VAC to +12VDC-Male Connector (specify S.I. Tech model number) |
| 6. External Power Supply          | S.I. Tech #2121, 110VAC to +12VDC-Female Connector (specify S.I.Tech model number)                             |
| 7. External Tempest Power Supply  | S.I. Tech #2103, 110/230VAC to 12VDC special Tempest   |
| 8. External Ethernet Power Supply | S.I. Tech #2125, 110/230VAC to 5VDC 1 Amp capacity,  |
| 9. +5VDC Host Supplied            | (STD-Do not add to Base Model Number)  |
| 10. 12VDC External Power Supply   | S.I.Tech #2164 - 110/230VAC to 12VDC, 1.7 Amp  |
| 11. 5VDC External Power Supply    | S.I.Tech #2166 - 110/230VAC to 5VDC 3A   |
| 12. 24VDC External Power Supply   | S.I.Tech #2163 - 110/230VAC to 24VDC   |

**How To Order** – The S.I. Tech Model Number is made up from the Base Model Number-plus one or more suffixes, if needed, for details not marked STD in the respective columns in the How To Order Table. Examples are given below each table.

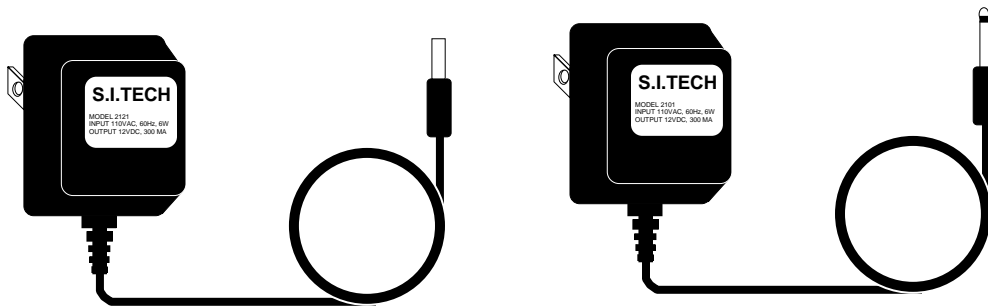

- Model 2101: 110VAC to 12 VDC – Male, 300 mA  
 Model 2102: 220VAC to 12 VDC – Male, 300 mA  
 Model 2103: 110/220VAC to 12 VDC – Female, Tempest, 300 mA  
 Model 2121: 110VAC to 12 VDC – Female, 300 mA  
 Model 2125: 110VAC to 5 VDC – Female, 1 Amp

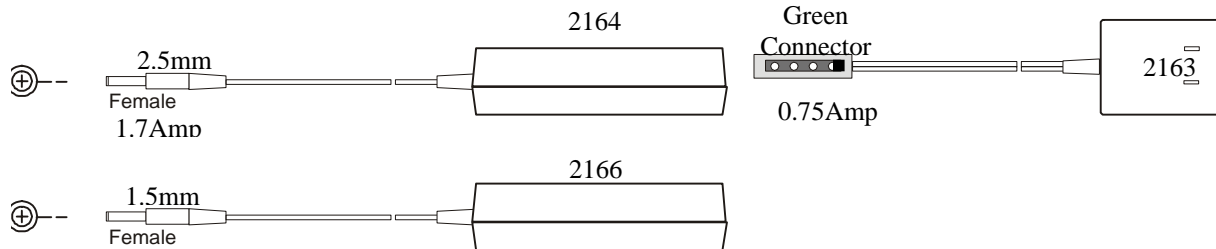

- Model 2163: 110/230VAC to 24VDC F 0.75Amp  
 Model 2164: 110/220VAC to 12VDC F 1.7Amp  
 Model 2166: 110/230VAC to 5VDC F 4.0Amp

*Specifications subject to change without notice.*

## BIT-DRIVER® MOUNTING OPTIONS

1. Table Top or Shelf

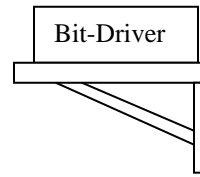
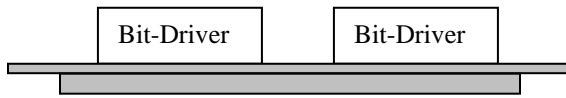

2. Rack 19", 1U



3. Rack 19", 3U and Cards

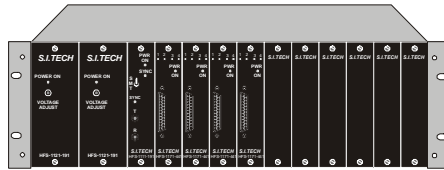

4. Minis (Light weight units)



5. DIN Rail

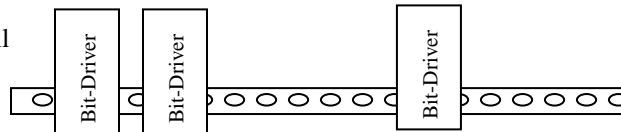

6. Wall Mount (L Bracket)

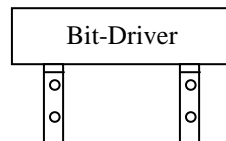

7. Panel Mounting Brackets

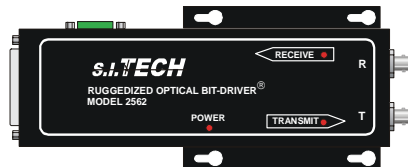

8. Shock Absorbing Mount



## 9. Panel (Flange) Mounting Mini Bit-Drivers



## 10. Direct Mounting to Equipment

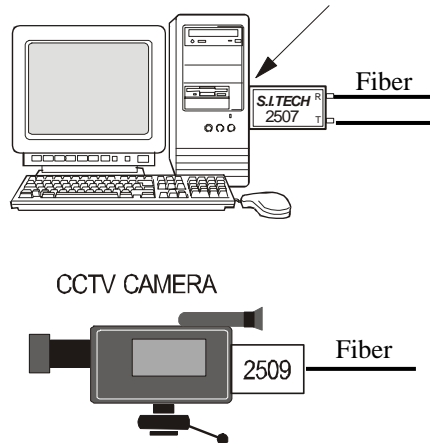

*Note: All options are not available on all products. Most products are light weight.*

## **FIBER OPTIC SYSTEM DESIGN**

## Introduction to System Operation

This guide is intended to help a fiber optic system engineer become familiar with the parameters involved in designing a complete link. It is not intended to answer all design questions, but rather to present alternatives available.

While complete ready-made systems are commercially available, this guide will help the interested engineer develop a system customized to his specific needs.

The first half of this guide is a simple introduction to system operation, component selection, and Local Area, Wide Area Networks (LAN/WAN). The second half is a detailed procedure for system design.

### The Advantages of Fibers:

Fiber optics communication offers several advantages over metallic (wire) or wireless systems.

Any form of outside electronic, magnetic, or radio frequency interference does not distort the transmitted signals. Therefore, optical systems are completely immune to lightning or high voltage interference.

Furthermore, optical fibers will emit no radiation, which ideally suits them for today's tougher standards in computer applications. Because optical signals do not require grounding connections, the transmitter and receiver are electrically isolated and free from ground loop problems.

With no chance of terminal-to-terminal ground potential shifts, plus safety from sparking and shock, fiber optics is increasingly the choice for many processing applications where safe operation in hazardous or flammable environments is a requirement.

Digital computing, telephone, and video broadcast systems require new avenues for improved transmission. The high signal bandwidth of optical fibers means increased channel capability. Also, longer cable runs require fewer repeaters, because fiber optic cables have extremely low attenuation rates. This ideally suits them for broadcast and long distance telecommunications use.

Compared to conventional coaxial cables with the same signal carrying ability, the smaller diameter and lighter weight of fiber optic cables means relatively easier installation, especially in crowded duct areas. A single conductor fiber optic cable weights about 9 lbs. per 1000 ft. A comparable coaxial cable weights 80 lbs. per 1000 ft. – about nine times more. Weight-conscious designers can save precious pounds using fiber optics, and increase capability.

<p><u>All Dielectric</u></p> <ul style="list-style-type: none"> <li>▪ Low Signal Radiation</li> <li>▪ Secure Transmission</li> <li>▪ RFI and EMI Immunity</li> <li>▪ High Voltage Installations</li> </ul>
<p><u>Small Size</u></p> <ul style="list-style-type: none"> <li>▪ Less Duct Space</li> <li>▪ Fewer Additional Ducts Installed</li> </ul>
<p><u>Low Attenuation</u></p> <ul style="list-style-type: none"> <li>▪ Greater Distance/Fewer Repeaters</li> <li>▪ Less Installation and Maintenance</li> </ul>
<p><u>Optical Signals</u></p> <ul style="list-style-type: none"> <li>▪ No Ground Loops</li> <li>▪ No Spark Hazard</li> <li>▪ Operation in Flammable Area</li> </ul>
<p><u>High Bandwidth</u></p> <ul style="list-style-type: none"> <li>▪ Future Signal Capability Expansion</li> </ul>

Table 1. Features of Fiber Optic Systems

Electronic “bugging” depends on electromagnetic monitoring. Fiber optic systems are immune to this technique. They have to be physically tapped to extract data, which decreases signal levels and increases error rates – both of which are readily detected. Table 1 summarized the many features of fiber optic systems.

### The Fiber Optic Link:

The simple schematic diagram shown in Figure 1 consists of an optical transmitter and receiver connected by a length of optical cable in a point-to-point link.

The optical transmitter converts electronic signal voltage into optical power, which is launched into the fiber by a light emitting diode (LED), laser diode (LD) or laser.

At the photodetector point, either a positive-intrinsic-negative (PIN) or avalanche photodiode (APD) capture the lightwave pulses for conversion back to electrical current.

It is the system designer's job to determine the most cost and signal efficient means to convey this optical power, knowing the trade-offs and limits of various components. He must also design the physical layout of the system.

The first of these concerns, signal quality, involves such factor as signal-to-noise ratio (SNR) in analog systems, and bit-error-rate (BER) in digital systems. When designing a system “from scratch” the designer must determine the required SNR or acceptable BER necessary to transfer the data. The next step is to determine the minimum optical power necessary at the receiver end. This can be obtained from component manufacture's published data.

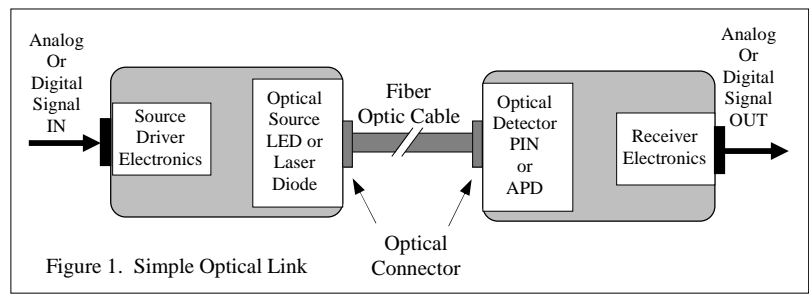

Figure 1. Simple Optical Link

Note: System Design Guide is reprinted with permission from Belden Corp.



## Introduction to System Operation (Continued)

### Losses and Limitations:

Link design consists basically of two functions: (1) the measuring of optical power losses occurring between the light source and the photodetector, and (2) determining bandwidth limitations on data carrying abilities imposed by the transmitter, fiber, and receiver.

Reductions in optical power loss, or attenuation, as the light pulse travels through the fiber are expressed in dB/Km (decibels per kilometer)

The decibel is a logarithmic expression of the ratio of the power entering a component and the power leaving it.

$$\text{dB} = 10 \log_{10} (\text{Power Out}/\text{Power In})$$

A 3dB loss means that half the power is lost. For example, starting with 500µw, you would now have 250µw. A 10 dB loss means that 10% of the power arrives at the receiver, a 90% loss.

Fiber optic links can operate with as little as 0.1% of the input power being received by the stated minimum requirements of the receiver selected.

### Transmission Power Loss:

The prime causes of optical attenuation in fiber systems are:

- Coupling loss
- Optical fiber loss
- Connector loss
- Splice loss

The sum of all the losses of each individual component between transmitter and receiver comprise the Optical Link Power Budget shown in Figure 2.

The designer must consider these losses and select a transmitter and receiver combination that will deliver enough power to faithfully reproduce the signal.

However, these losses are not exact, and manufacturers typically state ranges, or "best" and worst" case situations in order to account for product variations. Also some allowance may be required for such things as temperature variations.

Some safety margins should also be made for future repairs or splices to the system, and age degradation of the source emitter. For example, a 3dB margin for repairs and aging of the emitter is commonly employed.

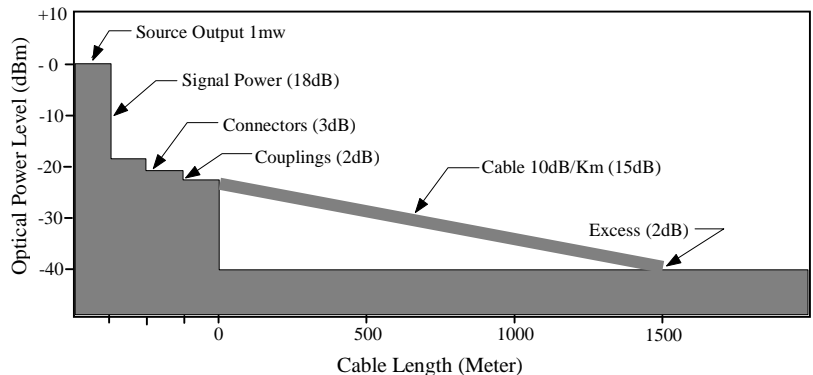

	Actual Power	Optical Power Level
Minimum optical power required by the receiver	0.1 µW	-40 dBm
Source output optical power	1 mW	0 dBm
<b>Total operating budget (optical power)</b>		<b>40 dB</b>
SNR voltage ratio required in the receiver is 36dB. The equivalent optical power is *		18 dB
<b>Remaining optical power for link</b>		<b>22 dB</b>
Link optical power losses:		
Cable	15 dB	
Connectors	3 dB	
Couplings	2 dB	
<b>Total</b>	<b>20 dB</b>	
<b>Excess budget</b>		<b>2 dB</b>

\*The optical power is related to the signal voltage ratio by a factor of two because  $\text{dB} = 10 \log P_1/P_2 = 10 \log I_1^2 R/I_2^2 R$ . Since  $V = IR$  then  $\text{dB} = 20 \log V_1/V_2$ .

Figure 2. Typical Optical Link Power Budget

### Coupling Loss:

The amount of optical power coupled into the fiber is dependent on the physical nature of the fiber used, and the source emitter.

Obviously, the larger the core diameter of the fiber, the more potential for accepting light. However, larger core fibers suffer bandwidth limitations that may outweigh coupling efficiency.

A change in core diameter from 50µm to 100µm (microns) represents an increase of four times in the amount of light coupled to the fiber.

Besides core size, the other measure of a fiber's ability to collect optical power is called numerical aperture (NA). This is a mathematical measure of the fiber core's ability to accept lightwaves from various angles and transmit them down the core.

A large difference between the refractive indices of the core and cladding means a larger NA.

For equal core size, a fiber with a larger NA will accept more lightwaves. A power increase by about a factor of two is achieved by going from an NA of 0.20 to one of 0.29.

We've combined the effects of core size and NA into an Optical Collection Factor, which can be considered a measure of the fiber's efficiency for optical radiation (see Table 2).

Fiber Core Dia. Microns	Numerical Aperture	Collection Factor	
		Relative*	dB Ratio
300	0.27	14.1	+11.5
200	0.27	6.2	+8.0
200	0.18	1.6	+2.2
100	0.28	1.0	+0.0
85	0.26	0.62	-2.1
62	0.29	0.4	-3.8
50	0.20	0.13	-8.9

\*Values normalized to short length of 100 micron core fiber.

Table 2. Optical Collection Factor

## Component Selection

### Source Emitters:

Optical emitters couple light into a fiber according to NA and core size. Using a light source not matched to a particular fiber's NA and core size will cause less than optimum light coupling for the system.

LED's are relatively inexpensive, reliable and easy-to-use because their electronic circuitry is less complex than that required for a laser. Typical laser and LED characteristics are shown in Table 3.

	Laser	LED
Light Output	6 dBm	0.6 dBm
Coupling Loss	3 dB	20 dB
Spectral Width at 800 nm	2 nm	40 nm
Spectral Width at 1300 nm	4 nm	100 nm
Temperature Sensitivity	Strong	Weak
Feedback Control	Yes	No
Failure Mechanisms	Many	Few
Cost (Relative)	100	1

Table 3. Comparison of Typical Parameters of Lasers and LEDs

Semiconductor lasers and LEDs are both direct transducers from electrical to optical radiation. LEDs couple less power into the fiber because they emit the optical radiation over a broader angle area. The laser is a much more complicated structure due to the requirement for a small dual-face cavity. Also its output is temperature dependent and the lifetime is less than the LED.

Several different LED packaging styles are commercially available, as seen in Figure 3.

The LED or laser diode can be packaged so that the fiber cable plugs directly into the device package. An alternative is fastening the fiber directly to the chip and leaving the opposite end available for a connector.

Matched transmitter and receiver units, plus a wide variety of other optic components ranging from discrete elements like LEDs, laser diodes, and detectors to complete rack-mounted modules are all readily available.

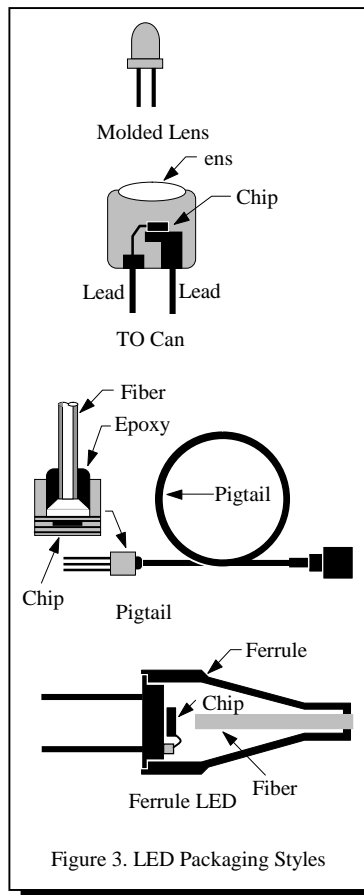

Figure 3. LED Packaging Styles

### Detectors:

Lightwave receivers use photodetectors, where the photons of light generate photoelectrons. A minimum average number of photons in each pulse is necessary to achieve a given-error probability (21 photons for  $10^{-9}$  error probability). Considerable amplification is necessary. For an avalanche-photodiode (APD) initial amplification is internal. For positive-intrinsic-negative detectors (PIN) this amplification is by external electronic amplifiers.

### Optical Fiber Loss:

We've already considered core size and numerical aperture as measures of fiber's ability to accept the optical power. Now let's consider what happens to the optical signal once it's launched.

In coaxial cable, high frequency signal strength decreases with distance and this is referred to as attenuation. Fiber does not have the same frequency dependent attenuation. Fiber frequency is constant until it reaches its bandwidth limit. Thus optical loss is proportional to distance.

This attenuation within the fiber is caused by absorption and scattering of lightwaves due to chemical impurities and molecular structure. These fiber properties absorb or scatter the optical radiation so that it escapes the core and is lost.

Attenuation within a fiber is specified by the manufacturer at certain wavelengths: for example 5dB/Km at 820 nanometers. This is done because fiber loss varies with wavelength, as seen in Figure 4.

These wavelength are measured in nanometers (nm) – billionths of a meter – which represent the distance between two cycles of the same wave. Wavelength is a descriptive property of electromagnetic radiation. Light and infrared radiation are portion of the total electromagnetic spectrum.

Microwaves, radar, television and radio operate in the longest wavelength areas. In between the ultraviolet and the microwave spectrums, we have fiber optic wavelengths, which are in the infrared spectrum.

### Fiber Selection:

Fibers are therefore optimized for operation at certain wavelengths. For example, less than 1dB/Km loss is attainable in  $50/125 \mu\text{m}$  multimode fiber operating at 1300 nm, and less than 3dB/Km (50% loss) is attainable for the same fiber operating at 850 nm. The  $50/125$  nomenclature indicates both the outside diameter of the core (50 microns) and the cladding (125 microns).

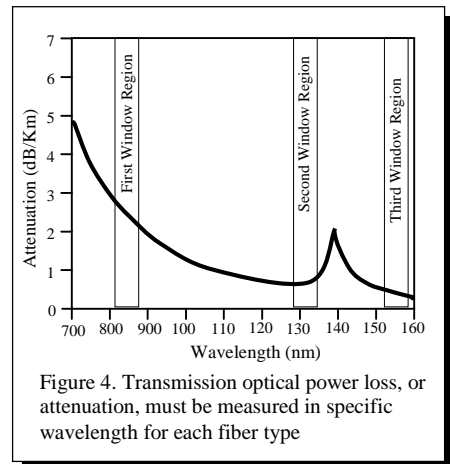

Figure 4. Transmission optical power loss, or attenuation, must be measured in specific wavelength for each fiber type

## Component Selection (Continued)

The favorable transmission regions within the optical spectrum for a fiber are referred to as "windows". The 800 to 900 nanometers region is the first window, 1100 to 1300 nanometers is the second window, and the third window occurs at about 1500 nanometers. In these spectral windows fibers have very low attenuation. The lowest losses occur in the infrared region around 1300 nm and again around 1500 nm.

Great improvements have been made in all fiber types so that premium fibers exhibit losses of less than 0.5dB/Km at wavelengths of 1300 and 1500 nm. However, source emitters and detectors for these regions are currently more expensive.

If the fiber is to perform well, the source chosen should provide optical radiation at the specified wavelength, and the detector should be sensitive to the same wavelength.

In coaxial and other metallic cables, very high frequency signals tend to be attenuated rapidly with distance. As a result, amplifiers and equalizers are required at periodic intervals to build up signals to usable levels.

However, each time an analog amplifier is added, noise is introduced to the metallic system, and the overall system signal-to-noise ratio degrades.

With optical communications, all of the light energy is at approximately the same frequency or wavelength. As a result, the attenuation of a specific wavelength is dependent only on distance. See Figure 5 for a comparison of attenuation differences between coaxial and fiber optic cable. The requirement for repeaters is, therefore, minimized and the need for equalizers is eliminated in fiber system.

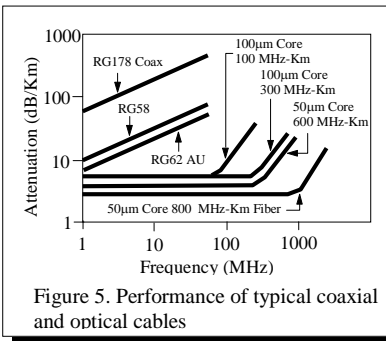

Figure 5. Performance of typical coaxial and optical cables

### Connector Loss:

Connector loss is a function of the physical alignment of one fiber core to another fiber core.

Scratches and dirt can also contaminate connector surfaces and severely reduce system performance, but most often the connector loss is due to misalignment or end separation.

Several styles of fiber optic connectors are available from major connector suppliers.

Typically, each has its own design and is generally not compatible with any other manufacturer's connectors. However, an SMA, ST, SC, or LC type connectors do offer mechanical compatibility.

Depending on connector type, different terminating techniques are used:

- Epoxy and polish: The fiber is epoxied in place in an alignment sleeve, then polished at the ferrule face.
- Optical and mechanical: Both lenses and rigid alignment tubes are commonly used. In addition, index matching mediums may be employed.

The optical power loss of a connector-to-connector interface typically runs between 0.25 and 1dB, depending on the style of the connector and the quality of the preparation.

### Splice Loss:

Two fibers may be joined in a permanent fashion by fusion, welding, chemical bonding, or mechanical joining. A splice loss that is introduced to the system may vary from as little as 0.15dB to 0.5dB.

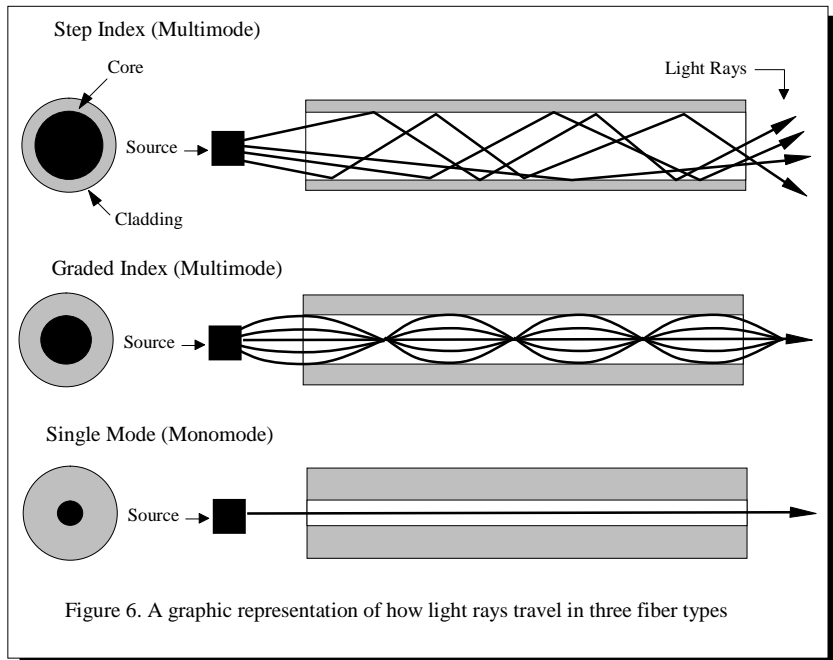

Figure 6. A graphic representation of how light rays travel in three fiber types

## Bandwidth

Up to this point, we've covered loss of optical signal power both within the fiber and within the system.

Now let's examine the other major determinant of fiber optic signal performance: bandwidth.

Because of their large comparative bandwidths, fibers can carry large amounts of information. A single graded index fiber can easily carry 500 million bits/second (Mb/s) of information. However, bandwidth capacity limits exist for all types of fibers and depend on the fiber and type of emitter employed.

The three fiber types shown in Figure 6 can be identified by the type of paths that the rays of each light pulse travel within their fiber cores.

To accurately reproduce data, light pulses must be kept separate and distinct with correct shape and spacing during transmission. Yet, the rays comprising each pulse travel in many different paths within a multimode fiber. For step index fibers, for example, modes traveling at different angles as they zigzag down the fiber arrive at the receiver end at different times.

This arrival time variance results in distorted and overlapping pulses at the receiver end as seen in Figure 7. This "modal dispersion", or spreading of the light pulse spreads the frequency that can be transmitted, because the detector cannot tell where one pulse ends and the next begins.

The time difference between the fastest and slowest mode of light entering the fiber at the same time and traveling a kilometer may only be 1 to 3 nanoseconds, yet this modal dispersion causes major limitations on the system's operating speeds over long distance. Doubling the distance, doubles the dispersion effect.

Just as optical power loss reduces signal performance, a system can be bandwidth limited when the shape of the light pulse is distorted beyond specified limits.

Modal dispersion is often expressed in nanoseconds per kilometer, e.g. 30ns/km. The same effect may also be expressed as a frequency, such as 200 MHz-km. This indicates that the fiber or system will operate efficiently up to 200 MHz before dispersion adversely affects signal performance over a one kilometer length. The same system could transmit a 100 MHz signal as far as two kilometers.

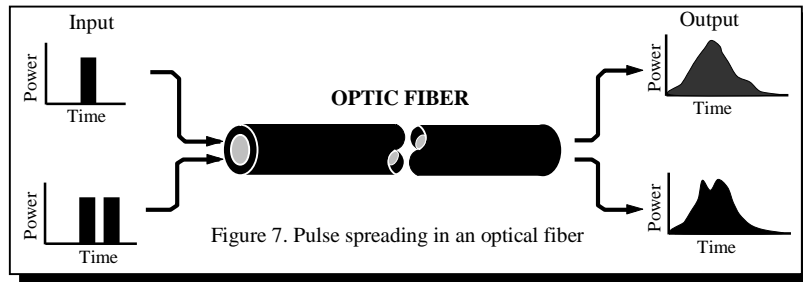

Dispersion makes the multimode step index fiber the least bandwidth efficient of the three types. It is therefore used for shorter runs and lower operating frequencies, e.g. 20 MHz-km.

Single mode fiber has small core sizes of 8 to 10  $\mu\text{m}$  diameter in order to allow only one lightwave ray to propagate down the fiber. Because modal dispersion is completely eliminated, this fiber has much greater bandwidths which can exceed several hundred gigahertz per kilometer (GHz-km).

However, fibers are susceptible to another type of dispersion problem caused by the fact that different wavelengths traveling at different velocities through a medium.

This "spectral dispersion" is evident when white light decomposes into a rainbow of colors by a glass prism. Each wavelength travels at a different speed leading to unequal amounts of bending of the rays associated with each color.

If the fiber system's spectral source emitted a single frequency of light, this spectral dispersion, or material dispersion (or chromatic dispersion, as it is also often called) would be eliminated. However, an LED light source has a spectral range of about 20 times that of a laser, and thus has much greater spectral dispersion. Dispersion in glass fiber disappears around 1.3  $\mu\text{m}$ , allowing mono mode fibers extremely large bandwidth capacities at this wavelength.

Mono mode fibers is typically used with laser emitters, because of their greater spectral purity. Precision connectors and splicing are required.

Because of their low loss, and high capacity qualities, mono mode fibers are the choice for constructing long, high data rate links, such as cross-country telecommunications.

Between mono mode and step index fibers, there are graded index fibers. Rays in a graded index fiber are gradually redirected back toward the core's axis during propagation to reduce the effects of modal dispersion. Graded index fibers have much greater bandwidth capacities than step index fibers. A 600 MHz-km graded index fiber can transmit a 20 MHz modulation signal as far as 30 km. The cost of this glass fiber is currently one of the lowest. Its low loss plus high bandwidth make it the fiber of choice for most local area network applications, for example.

### LCF (Laser Certified or Laser Enhanced Fiber):

The new fiber features LCF to handle the new light sources required in short wavelength gigabit Ethernet systems. The new light sources, named VCSEL (Vertical Cavity Surface Emitting Lasers) are designed to operate at the short wavelength of 850nm, the same wavelength as today's LED light sources. LCF 62.5 and 50 micron multimode fiber ensures compliance with new laser technology. The LCF fiber utilizes enhanced bandwidth and tight attenuation limits to meet and exceed the EIA/TIA-TSB72 300 meter backbone length.

LCF fiber has been deployed across the entire cable series. It is operational with current LED light sources and exceeds FDDI+ performance specifications. LCF will be also be able to handle low-cost, long-wavelength VCSEL light sources currently being developed.

LCF Lengths for Gigabit Ethernet			
Core Size	Wavelength	SX	LX
62.5	850nm	300m	N/A
	1300nm	600m	600m
50	850nm	300m	N/A
	1300nm	3600m	600m

## Local Area Networks (LAN)

### Bandwidth Summary:

To this point we've covered how pulse spreading or dispersion limits the maximum bandwidth that may be used with fibers. The different propagation pathways cause delays, or modal dispersion in multimode fibers.

Modal dispersion is the principal bandwidth limitation for laser-based multimode fiber systems at 850 nanometers, and for both laser and LED systems at 1300 nanometers.

Spectral dispersion provides the principal bandwidth limitation for LED based systems at the first window of 850 nanometers of about 100 MHz-km, and for single mode laser-based systems (typically more than 50 GHz-km) at the 1300 nanometer region.

The basic loss mechanism, or attenuation, within fibers is caused by light scattering which varies by wavelength. The 1300 nanometer wavelength is important because not only is attenuation low at this point, but spectral dispersion is generally a minimum at this wavelength.

Fibers have a constant loss over a wide range of modulation rates, but there is a rapid increase in effective loss when pulse dispersion becomes compatible to the pulse period. Contrast this with base band metallic systems where attenuation increases as the square root of the modulation rate. Provided dispersion is small, fiber systems do not require equalization and line amplifiers which are necessary with metallic systems.

### Local Area Networks (LAN):

The explosive growth of personal computing in the business marketplace and the increasing sophistication of multiple-function local area networks are forcing system developers into an examination of not only what operating systems to use, but also what would be the optimum cable/system design.

The growing requirements for bandwidth in computer applications, and the need to adapt to other inter- and intra-building telecommunications needs such as telephone, security, alarm and video have all dramatically increased the demand for optical fiber.

Fiber optic LANs generally have a maximum link distance between transmitter/receiver pairs of 2 km. They may be isolated to only one floor or one building, or be interconnected with other networks among several buildings.

A system can be low-speed, low-capacity such as telephone, or high-speed, high-capacity such as video. Although copper and fiber can both be used or intermixed in a LAN system, the high information capacity and upgradeability of fiber is increasingly making it the choice. Instead of rewiring to add future capacity, changing the electronic hardware at the system ends is all that's necessary to alter these systems. Many designers add extra fibers to a system for this purpose.

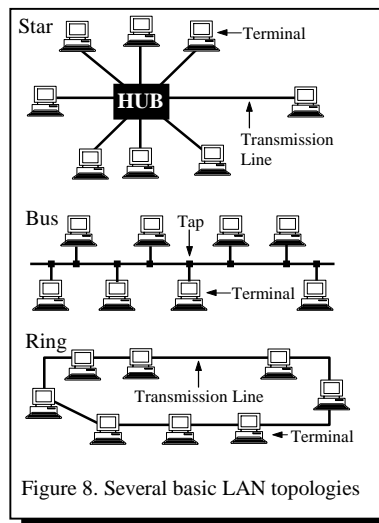

Figure 8 shows several examples of the basic LAN topologies: star, ring, and bus.

Star LANs are arranged around a single hub that may act as a central controller for network. Transmission sent from one node or terminal must first pass through the hub. This hub can simply be a passive star coupler or an active controller or a switch.

In a ring type network, all terminals are linked in a point-to-point series. If one part fails, the system is down unless bypass components are used. To avoid conflicting data demands such systems use a bit pattern, called a token. The token is circulated to each node allowing that node to capture the token and the right to transmit data. IBM has a ring network shown in Figure 9. Other systems and software are also on the market.

Networks based on a bus topology also use a token passing scheme, or an access scheme known as carrier-sense multiple access with collision detection (CSMA/CD), or collision

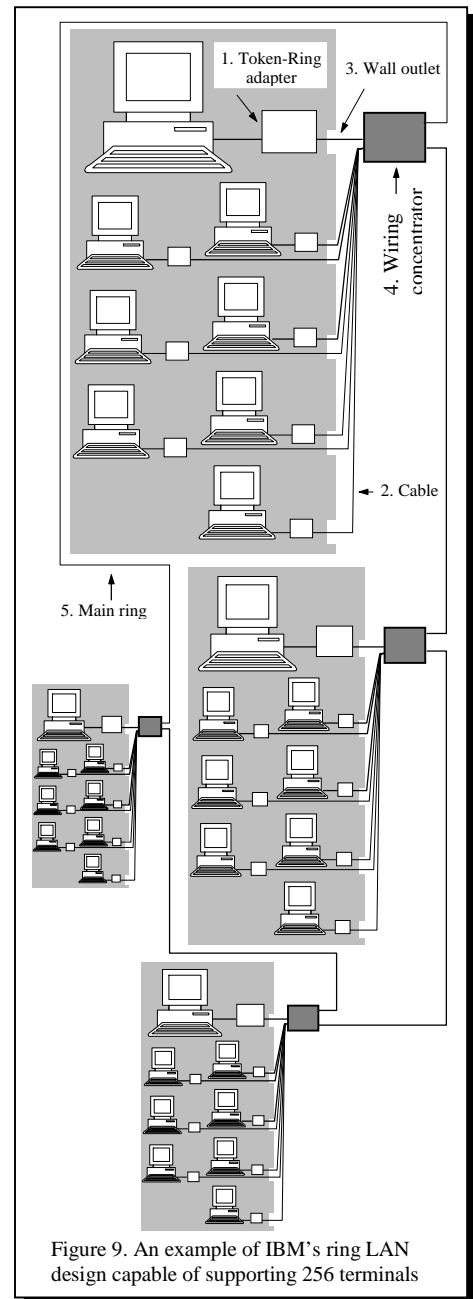

Figure 9. An example of IBM's ring LAN design capable of supporting 256 terminals

avoidance (CSMA/CA). Like a ring, messages on the bus are broadcast to all terminals. Since all the terminals tap into a single main trunk channel like branches on a tree, messages do not have to be repeated.

Most LANs use combinations of bus and star networks today because of speed, easy installation or retrofit, and the fact that each node can be passive so that if one fails the network keeps functioning.

## Local Area Networks (Continued)

### Interconnecting Components:

LAN networks can be easily configured because the fiber optic cable can be easily strung in a plenum on a single floor, up a raceway between floors, or among several buildings.

Figures 10 and 11 show typical examples of LAN layouts for multi-premise and single locations. There are fiber optic component pieces corresponding to every piece of electronic hardware used with any other LAN type. These devices appear in a system wherever a user connects, or where several lines join together at a node. These devices can be active, such as the transmitters and receivers that have already been discussed, or passive such as taps, distributors, couplers, concentrators, switches, relays, multiplexers, concentrators, switches, relays, multiplexers, and cross connection cabinets. They are available from a variety of vendors as discrete components, in rack-mounted modules, or as fully integrated system.

Optical taps or "Ts", and optical mixers or "star" couplers are shown in Figures 12 and 13. Both are examples of concentrators which actively or passively combine signals at nodes or user connection points in a LAN system.

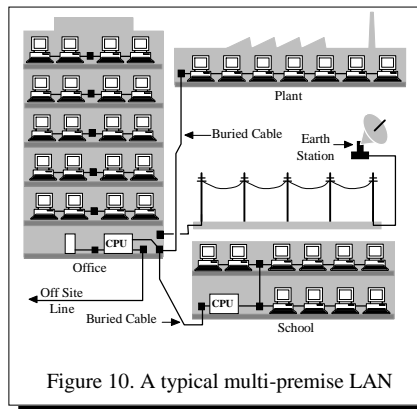

Figure 10. A typical multi-premise LAN

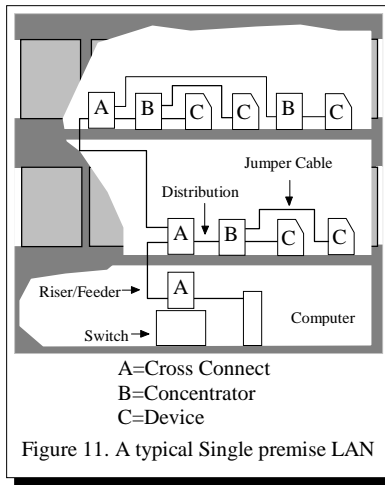

Figure 11. A typical Single premise LAN

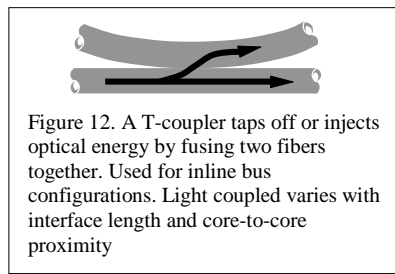

Figure 12. A T-coupler taps off or injects optical energy by fusing two fibers together. Used for inline bus configurations. Light coupled varies with interface length and core-to-core proximity

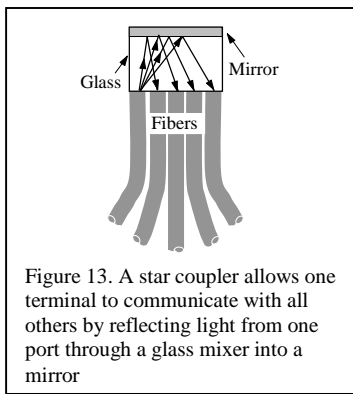

Figure 13. A star coupler allows one terminal to communicate with all others by reflecting light from one port through a glass mixer into a mirror

Simple LAN systems use "Ts", stars and other passive components between transmitter/receiver pairs. More complex systems require active components to combine, route and sometimes re-amplify the signal. Data transmission trends as outlined in Figure 14 are moving toward more active nodes as the need for greater fiber optic system flexibility, data speed, and link length increases.

As previously discussed, optical power losses occur whenever a fiber is terminated or coupled. Therefore, allowance for tapped bus or other LAN configuration requires that connectors must be factored into the system's loss budget analysis. Since many connectors are used in typical LAN networks, each must have a known loss factor.

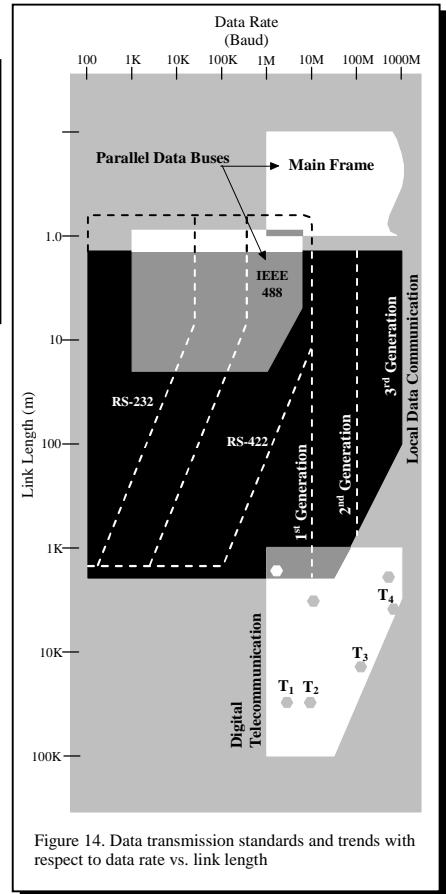

Figure 14. Data transmission standards and trends with respect to data rate vs. link length

## System Design Procedure

### System Analysis:

The system designer must proceed through the following five steps in order to develop a fiber optic communication system:

1. Specify the system's operational requirements.
2. Describe the physical and environmental requirements.
3. Compute the signal optical power budget.
4. Perform a signal bandwidth analysis.
5. Review the system design.

Important considerations in these steps of the design process are detailed in Figure 15. Worksheets for compiling all the data necessary to complete the design are included in the back of this brochure.

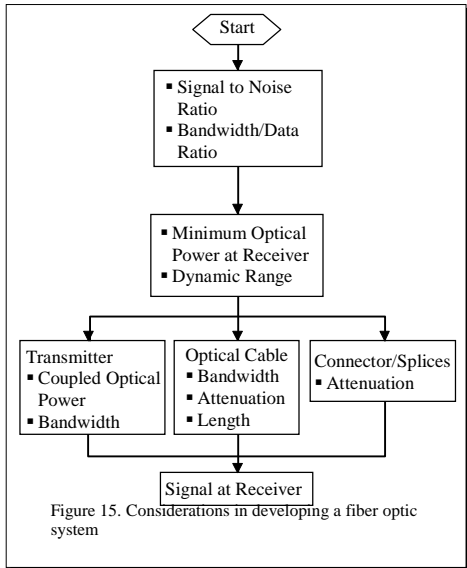

### System Operational Requirements: (Step 1)

The system design process begins with a determination of the signal-to-noise ratio which depends on the bandwidth or data rate for an application. This implies a choice of signal types, either analog or digital, since even a simple point-to-point link will employ appropriate hardware. The goal is to establish what optical power level will be required at the optical detector inside the receiver unit.

As shown in Figure 16, fiber can handle either analog or digital transmission and it offers the additional option of future upgrading by simply changing the electronics hardware at the transmitter and receiver ends. For this reason most fiber system designers specify more fiber bandwidth capacity than is minimally required.

### Analog Signals:

Analog signal such as video and audio can be directly modulate optical output by causing the optical emitter to brighten and dim. This is called intensity modulation and is a simple and straightforward method of encoding lightwave signals.

Improvements in both signal-to-noise and linearity can be obtained by the use of frequency modulation (FM) techniques. Here the information source is used to frequency modulate a subcarrier, then this signal is used to intensity modulate an LED or laser. Because of material and intermodal dispersion factors, FM links normally require fibers with bandwidths of 200 MHz-km and higher. Short unrepeated links are occasionally analog modulation. However most lightwave applications today use digital transmission with simple on-off modulation.

### Digital Signals:

In fiber optics, a digital pulse can be formed by turning the source "on" for a brief instant. The time of optical radiation emission is the pulse. A binary "1" state can be used to represent optical power turned "on", while a binary "0" state is used to represent "off". These two states represent binary signals. Digital signals consist of a series of bits that result in the emitter being "on" or "off" as shown in Figure 17.

The time it takes for a pulse to reach full amplitude is the rise time. Faster rise and fall times allow more pulses per second, consequently more bits of information can be transmitted.

In digital systems one parameter for system performance is bit error rate (BER). The majority of digital systems achieve a BER of  $1 \times 10^{-9}$  (1 error in  $10^9$  bits)

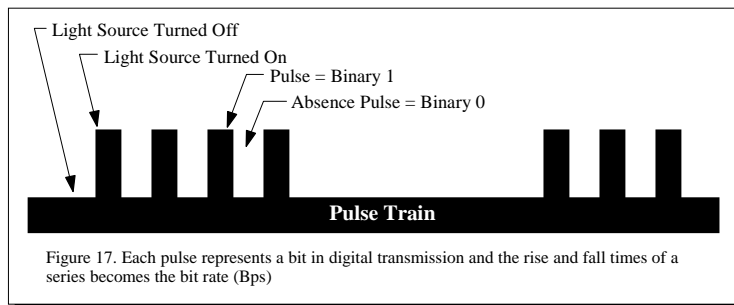
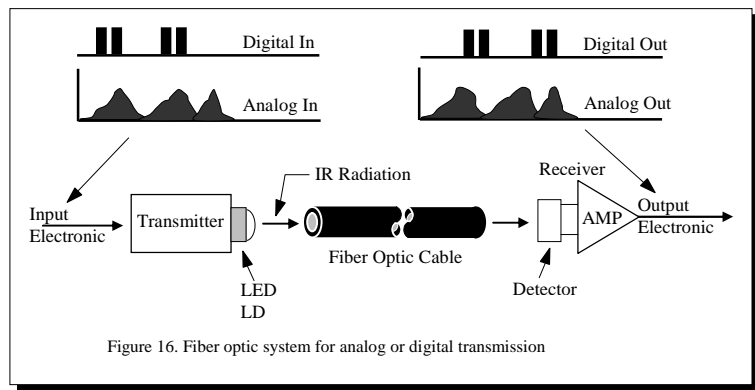

## System Design Procedure (Continued)

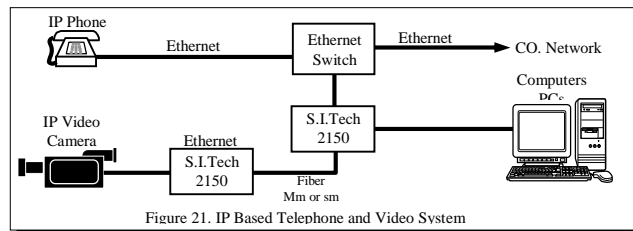
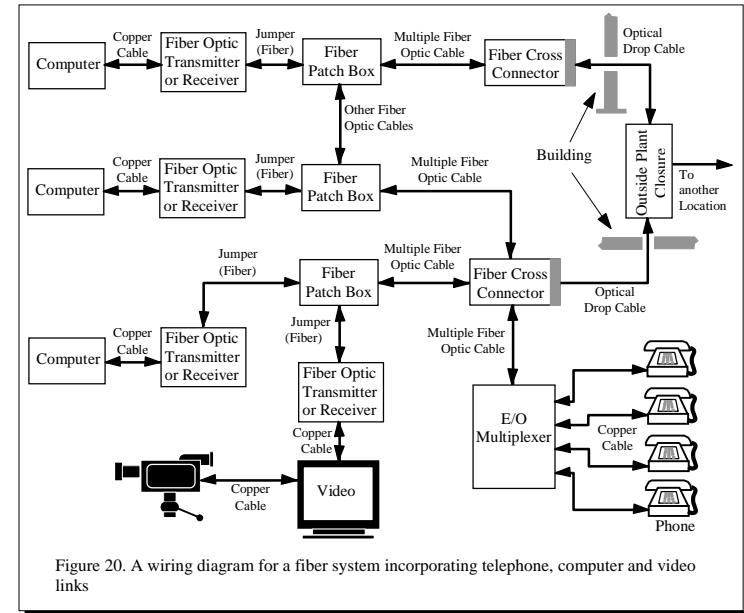
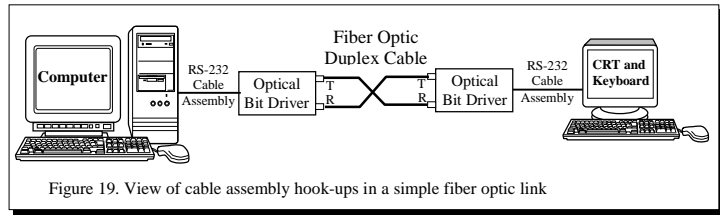
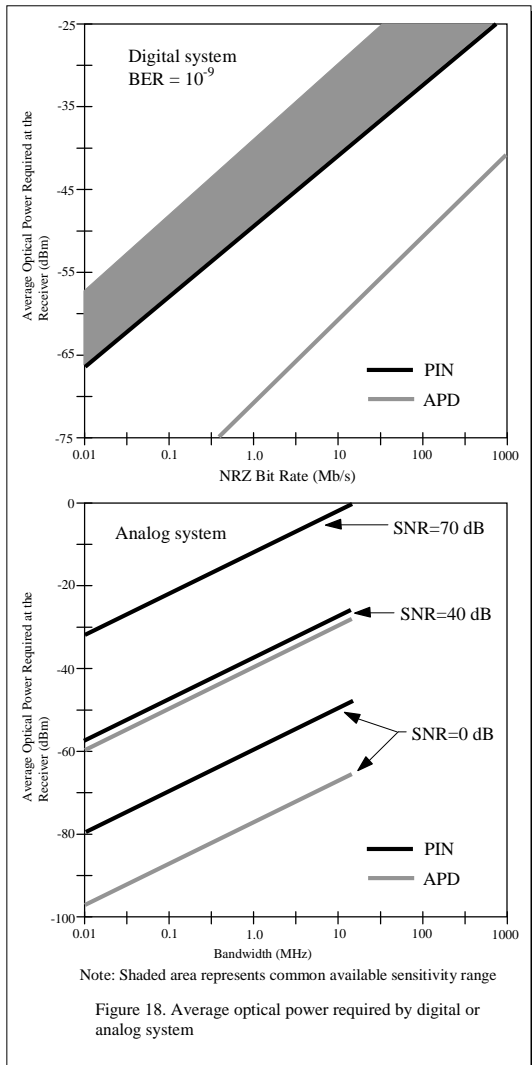

There is a length dependence with digital systems because the farther a pulse has to travel down a fiber the more distortion occurs. The resulting optical power level required at the detector is a function of the data rate or bandwidth. These levels for digital and analog signals are indicated for silicon detectors at 850 nm in Figure 18.

Once the application (TV, telephone, or computer), the type of signals (analog, digital), and the data rate have been determined, the next step is to describe the physical layout and environmental requirements.

### System Layout: (Step2)

To determine the components necessary to complete a fiber optic system requires detailing run lengths and determining system operating environments.

A simple point-to-point system as shown in Figure 19, or a more elaborate local area network involving telephone, data, video, control and alarm functions as shown in Figure 20, are both becoming commonplace installations for fiber optic cable. Current fiber optic technology employs a separate fiber to transmit the signals in one direction.

Therefore most point-to-point systems will require at least two fibers for duplex communications. Higher fiber count cables are also ready available.

The system designer should develop a layout schematic similar to the one shown in Figure 20 and use the resulting information on the worksheets at the back of this brochure.



## System Design Procedure (Continued)

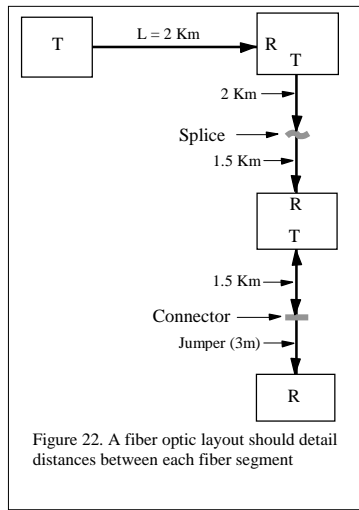

Figure 22. A fiber optic layout should detail distances between each fiber segment

### Signal Optical Power Budget: (Step 3)

With the system layout and components known, it's now possible for the designer to compute expected losses at each point in the system as shown in Figure 23.

Every component including fiber has a range of optical loss due to variations in manufacture. An LED device, for example, will be specified with a minimum, average, and maximum optical output power. The range may be as much as 4 dB (60%).

Detectors also have sensitive ranges. It is up to the system designer to determine the optical power necessary at the detector surface from information supplied by the manufacturer.

Once the receiver and transmitter power levels have been established it is possible to consider the power transmitted by various cable lengths. This can be seen by plotting the power on a diagram such as in Figure 24.

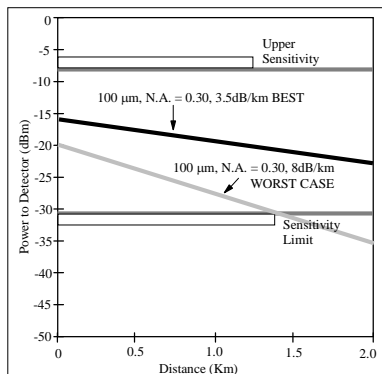

Figure 24. Use stated receiver and transmitter ranges to determine fiber distances (e.g. 10 Mb/s transmitter at 850 nm 100 micron core fiber)

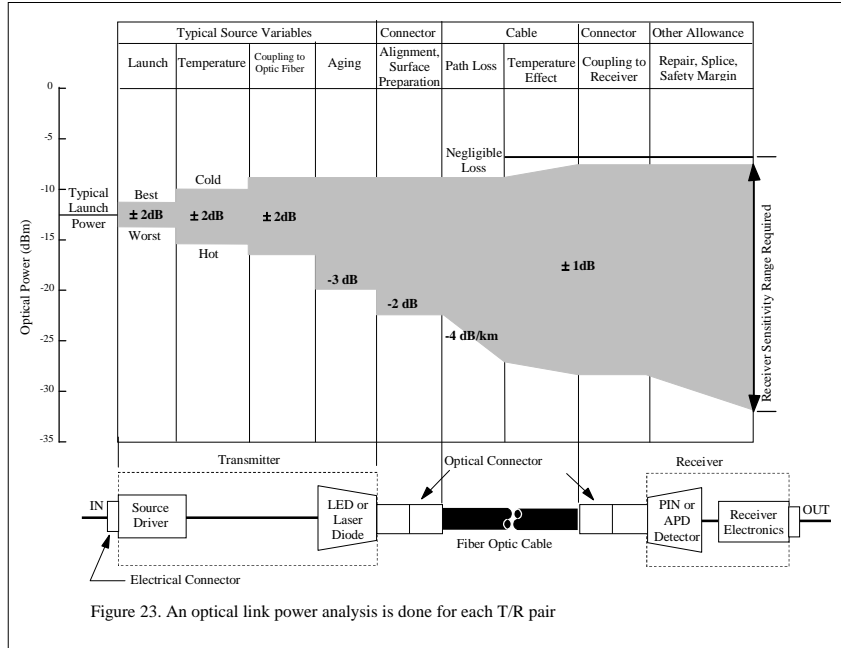

Figure 23. An optical link power analysis is done for each T/R pair

In the example shown, a fiber with a 100 micron core has been analyzed for use with a 10 Mb/s transmitter at the 850 nm wavelength. Both the best and worst case curves are shown with the average expected range in between.

The detector sensitivity upper and lower limits are also shown. This figure indicates that a transmission distance of about 1.4 km is maximum.

The same technique can be used to compare two fiber core sizes as shown in Figure 24. Here the 50/125 fiber is acceptable if the maximum length is less than 0.5 km.

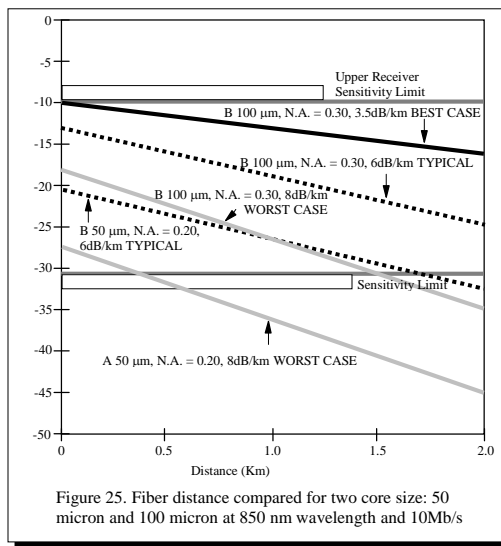

Figure 25. Fiber distance compared for two core size: 50 micron and 100 micron at 850 nm wavelength and 10Mb/s

Starting power levels vary due to the emitter launch range. When taps and splices are included, their values can be considered as part of the launch loss, or displayed where they might occur in the system as in Figure 26.

Worksheets are included at the end of this brochure for determining your optical power budget. Use either peak or average optical power values for determining attenuation throughout the system. Be consistent in your choice throughout the system analysis.

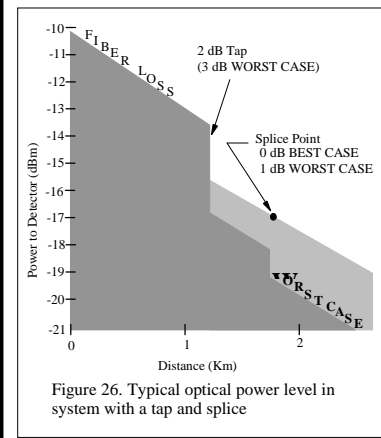

Figure 26. Typical optical power level in system with a tap and splice

## System Design Procedure (Continued)

Power couple to various fiber types by a few typical source emitters is detailed in Figure 27. Coupled power for each fiber type under consideration should be entered in the appropriate column on the worksheet. Allow approximately 4 to 6 dB to account for thermal variations in the optical fiber, repair of damaged cable, and source degradation over time.

### Fiber Selection:

Basic fiber types are presented in Figure 28. The various fiber properties such as attenuation, numerical aperture (NA), core diameter have all been covered earlier in this brochure. NA and core diameter must be considered for launch conditions. All fibers can be compared over one kilometer lengths for fiber properties and relative optical power as in Table 4.

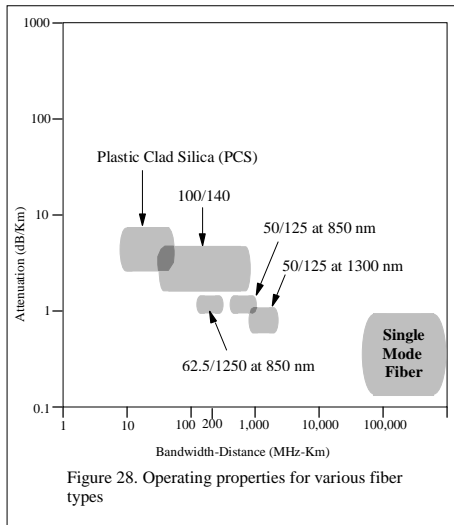

Figure 28. Operating properties for various fiber types

Certain fiber types have proven suitable for special applications.

Choices for most LAN or data systems, for example, currently centers on the all-silica fibers. Here various core/cladding constructions are available with tradeoffs in performance, cost, and standardization. In past four sizes are most often were considered. 50 micron fiber is now available with laser enhanced performance at 850nm.

Core	Cladding	Bandwidth	
		850	1300
50	125	600	600
62.5	125	200	500
85	125	200	600
100	125	150	500

All are multimode, graded-index fibers to assure adequate bandwidth and low enough loss to be ideal for typical LAN capacity Video and CATV systems often employ 50/125 and single mode fibers because of their high bandwidth and low loss performance characteristics. Modern intercity telephone trunks also employ single mode fibers.

Fibers may be selected in a variety of bandwidths and attenuations, in either one or two window versions. Again, attenuation of optical fibers will vary depending on the source wavelength of the transmitter. A fiber cable loss table for Belden products is shown in Table 5, and can be used with the Step 3 Worksheet at the end of this brochure.

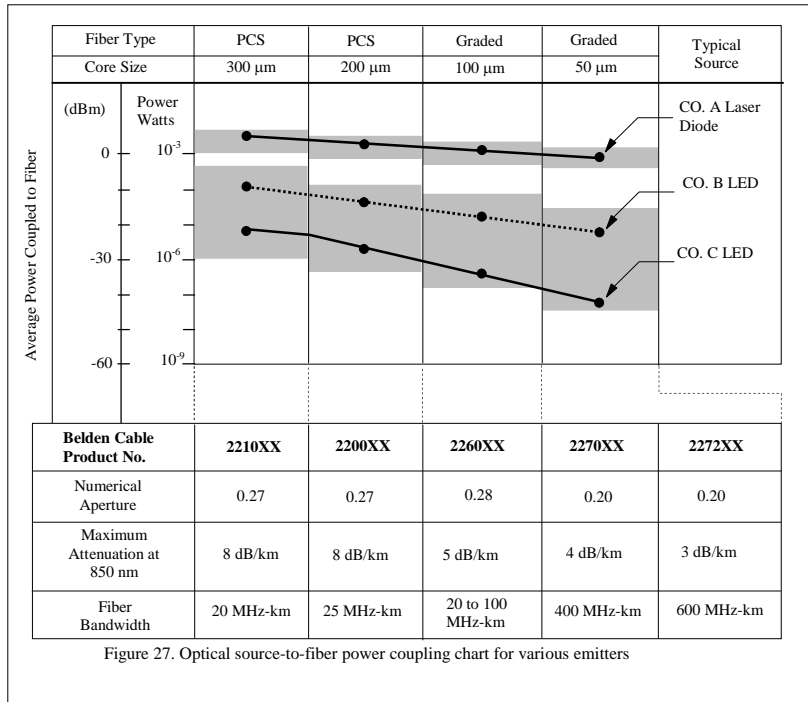

Figure 27. Optical source-to-fiber power coupling chart for various emitters

Type of Fiber			Numerical Aperture	Relative Collection Factor (dB) <sup>1</sup>	Relative Optical Power (dB) at 1 km <sup>2</sup>
Material Structure	Type	Core Dia. Micron (µm)			
Silica	Single Mode	10	0.08	-31.0 <sup>3</sup>	-28.0
Silica	Multimode	50	0.20	-8.9	-6.9
Silica	Multimode	62.5	0.29	-3.8	-2.8
Silica	Multimode	85	0.26	-2.1	-1.1
Silica	Multimode	100	0.28	0.0	0.0
PCS	Multimode	200	0.27	+5.7	+3.7
PCS	Multimode	300	0.27	+9.2	+7.2

1. Relative amount of radiation coupled to fiber based on 1 km length NA value. Shorter lengths may have higher values.
2. Based on the difference in transmission over a 1 km length of cable using the 100 micron core fiber at 5 dB/km (850 nm) as the basis for normalization.
3. Primary use at 1300 nm or 1550 nm.

Table 4. Optical power comparison for various fiber types

Material Structure	Core Dia. Micron (µm)	Numerical Aperture	Attn * DB/km	Bandwidth MHz/km
Silica	50	0.20	4	400
Silica	50	0.20	3	600
Silica	62.5	0.29	4	200
Silica	85	0.26	4	200
Silica	100	0.28	5	100
PCS	200	0.27	7	25
PCS	300	0.27	7	20

\*Values for 850 nm wavelength

Table 5. Typical optical fiber cable performance

## System Design Procedure (Continued)

### Bandwidth Analysis: (Step 4)

While attenuation is one major determinant in fiber optic system performance, bandwidth is the other. Here the goal is to assure that all components have sufficient bandwidth to transmit the required signal. Local area networks typically require 20 to 600 MHz-km fiber bandwidth. On the other hand, long-haul telephone systems employ large distance between repeaters and require the 100,0000 MHz-km bandwidths associated with single mode fiber.

A fiber has a 3dB (half power) optical signal magnitude decrease at the bandwidth specified for that fiber. Conversion between electrical and optical bandwidth for the system or any component such as a fiber, receiver, or transmitter unit is performed by using:  $BW_{optical} = 1.41 BW_{electrical}$ . In some cases a receiver or transmitter manufacturer will specify risetimes. The electrical bandwidth (BW in MHz) for a component is related to its 10% - 90% risetime (t in nanoseconds) by:  $BW = 350/t$  and the total system electrical bandwidth is obtained from individual component bandwidth by:

$$\frac{1}{BW^2} = \frac{1}{BW_R^2} + \frac{1}{BW_C^2} + \frac{1}{BW_T^2}$$

Where  $BW_R$ ,  $BW_C$  and  $BW_T$  are the electrical bandwidth of the receiver, cable and transmitter respectively.

For digital systems the system bandwidth will depend on the data rate (R in bits per second) and the coding format according to:

$$BW_{system} = R/K$$

Where K equals 1.4 for a non-return-to-zero (NRZ) coding format and 1.0 for a return-to-zero (RZ) format.

The system bandwidth is limited by the lowest bandwidth component in the link. When high bandwidth fiber is used for example, the system frequency response may be more influenced by the terminal equipment than the fiber.

A general guideline in selecting the terminal equipment is to choose a receiver with a bandwidth equal to or greater than the required system bandwidth. The transmitter and optical fiber should then have bandwidths about 1.5 to 2 times greater than the receiver.

Again, systems are usually more cost effective at higher data rates. And allowing for more fiber bandwidth than is minimally required, for example, allows system capacity to be upgraded later. Care should be taken in estimating the optical bandwidth in MHz-km of series connected cable runs with lengths greater than a kilometer.

The approximate relationship between the total cable bandwidth ( $BW_{CO}$ ) and one kilometer section fiber bandwidth ( $BW_f$ ) is:  $BW_f = BW_{CO} (L)^x$

L is the fiber length in kilometers. The x equals 1.0 for cable run lengths (L) of one kilometer or less. And x equals 0.75 for fiber in cable run lengths greater than one kilometer.

The Step 4 Worksheet provides a simple example and a blank form to fill in the necessary values for a bandwidth analysis. Here the  $1/BW^2$  terms are individually calculated and then combined in a series of steps to yield the total system bandwidth.

### System Review: (Step 5)

Now is the time for the system designer to review all of the pieces to determine that all work together to deliver the right signal to the right place at the right time. These combined parameters can be listed Step 5 Worksheet.

The complete cable structure can be established using the following criteria:

- Cable Construction
  - Hybrid \_\_\_\_\_ All Dielectric \_\_\_\_\_
  - Metal Strength Members \_\_\_\_\_
  - Indoor \_\_\_\_\_ Outdoor \_\_\_\_\_
  - Armored \_\_\_\_\_
- Jacket Materials
  - PVC \_\_\_\_\_ Polyurethane \_\_\_\_\_
  - Polyethylene \_\_\_\_\_ Other \_\_\_\_\_
- Environmental Protection
  - Flame Retardancy \_\_\_\_\_
  - Or UL code \_\_\_\_\_
  - Sunlight Resistance \_\_\_\_\_
  - Abrasion Resistance \_\_\_\_\_
  - Water Blocking (gel fill) \_\_\_\_\_
  - Rodent Protection (armor) \_\_\_\_\_
  - Nuclear Radiation Resistance \_\_\_\_\_
  - Other \_\_\_\_\_
- Chemical Resistance
  - To Oil \_\_\_\_\_, Acid \_\_\_\_\_
  - Alkali \_\_\_\_\_, Solvents \_\_\_\_\_

- Fiber Features
  - Number of Fibers \_\_\_\_\_
  - Fiber Type \_\_\_\_\_ Core Size \_\_\_\_\_
  - Wavelength \_\_\_\_\_
  - Attenuation \_\_\_\_\_
  - Bandwidth \_\_\_\_\_
  - NA \_\_\_\_\_
  - Double Window \_\_\_\_\_

- Number and Type of Electrical Connectors \_\_\_\_\_

Specific materials and multi-fiber constructions have resulted in numerous cable designs which incorporate a variety of fibers to meet specific applications. Hybrid designs having both optical fibers and metallic conductors.

Hopefully this guide will permit the identification and description of a useful fiber optic system. Due to advancing technology and extensive tradeoffs, system design is constantly changing. This guide is based on currently available components. To keep abreast of changes, ask questions, or to request design assistance, contact Belden's local sales representative or the regional offices listed on the back cover of this booklet.

## Worksheets

### Step 1. System Operational Requirements

#### Application

Video \_\_\_\_\_ Telecom/WAN \_\_\_\_\_ Computer/LAN \_\_\_\_\_ Industrial \_\_\_\_\_ Other \_\_\_\_\_

#### Type of Signals

Analog:

- System Bandwidth \_\_\_\_\_ MHz
- System Signal-to-Noise Ratio \_\_\_\_\_ dB

Digital:

- Coding Scheme NRZ \_\_\_\_\_ RZ \_\_\_\_\_ Other \_\_\_\_\_
- Data Rate \_\_\_\_\_ Bits Per Second
- Bit Error Rate  $10^{-8}$  \_\_\_\_\_  $10^{-9}$  \_\_\_\_\_ Other \_\_\_\_\_
- Logic Format \_\_\_\_\_ TTL \_\_\_\_\_ ECL \_\_\_\_\_  
Other \_\_\_\_\_

Optical:

- (A) Minimum Required Optical Power \_\_\_\_\_ dBm Average \_\_\_\_\_ Peak \_\_\_\_\_  
(from manufacturer's data)
  - (R) Receiver Dynamic Range (from manufacturer's data) \_\_\_\_\_ dBm
  - (S) Maximum Optical Power allowed at receiver (A+R) \_\_\_\_\_ dBm Average \_\_\_\_\_ Peak \_\_\_\_\_
- Number of Channels \_\_\_\_\_

#### Terminal Equipment

Space available for:

Transmitter \_\_\_\_\_ "x" \_\_\_\_\_ "x" \_\_\_\_\_ "  
Receiver \_\_\_\_\_ "x" \_\_\_\_\_ "x" \_\_\_\_\_ "  
Repeater \_\_\_\_\_ "x" \_\_\_\_\_ "x" \_\_\_\_\_ "

Terminal Equipment Connections RS-232 \_\_\_\_\_ RS-422 \_\_\_\_\_ RS-485 \_\_\_\_\_ Twinax \_\_\_\_\_ TP \_\_\_\_\_ Ethernet \_\_\_\_\_ USB \_\_\_\_\_ Other \_\_\_\_\_

Terminal Equipment Mounting PC Board \_\_\_\_\_ Rack \_\_\_\_\_ Dinrail \_\_\_\_\_ Standalone \_\_\_\_\_ Other \_\_\_\_\_

Power Supply Requirements:

Voltages AC \_\_\_\_\_ DC \_\_\_\_\_

Current \_\_\_\_\_ mA

Frequency \_\_\_\_\_ Hz

### Step 2: System Layout

#### System Location

Locations of Equipment Building \_\_\_\_\_ Other \_\_\_\_\_

Distance Between Stations Meters \_\_\_\_\_

Routing Plan for Cables \_\_\_\_\_

#### System Environment

For Terminals and Repeaters Indoor \_\_\_\_\_ Outdoor \_\_\_\_\_

For Cables (based on routing) Ducts \_\_\_\_\_ Buried \_\_\_\_\_ Aerial \_\_\_\_\_ Other \_\_\_\_\_

Temperature Range \_\_\_\_\_ °C to \_\_\_\_\_ °C

High Voltage Present Yes \_\_\_\_\_ No \_\_\_\_\_ Volts \_\_\_\_\_

Water Presence Yes \_\_\_\_\_ No \_\_\_\_\_

#### Installation Constraints

Installation Equipment \_\_\_\_\_

Cable Pull Lengths \_\_\_\_\_ Meters

## Worksheets (Continued)

### Step 3. Signal Optical Power Budget

#### Example:

	Required Bandwidth (Data Rate)	(NRZ, 1.4 Mbps)
	Required Bit Error Rate	$10^{-9}$
(L)	Required Length of Run	2 Km
(A)	Minimum Optical Power Required for PIN Type Receiver	-39 dBm Average
(R)	Receiver Dynamic Range	20 dB
	Maximum Optical Power Allowed at Receiver (A+R)	-19 dBm
	Transmitter Type (Wavelength)	LED 850 nm

	Source-to-Fiber Coupling: Fiber (Core Diameter)	200 $\mu\text{m}$	100 $\mu\text{m}$	62.5 $\mu\text{m}$
(B)	Coupled Power (From Figure 26)	-5 dBm	-11 dBm	-20 dBm
(C)	Power Difference (B-A)	34 dB	28 dB	19 dB
(D)	Degradation Allowance	6 dB	6 dB	6 dB
(E)	Power Margin (C-D)	28 dB	22 dB	13 dB
(F)	2 Connectors (Average Loss: 0.5 to 3dB/Connector)	6 dB	1 dB	1 dB
(G)	0 Splice (Average Loss: 0.25 dB/splice)	0 dB	0 dB	0 dB
(H)	Maximum Cable Attenuation Allowed (E-F-G)	22 dB	21 dB	12 dB
(I)	Cable Attenuation at 850 nm (From chart in Figure 26)	8 dB/Km	6 dB/Km	5 dB/Km
(J)	Total Cable Loss (I x L)	16 dB	12 dB	10 dB
	Maximum cable Length Allowed (H/I)	2.75 Km	3.5 Km	2.4 Km
(K)	Excess Power Margin	6 dB	9 dB	2 dB

#### Worksheet:

	Required Bandwidth (Data Rate)	_____
	Required Bit Error Rate	_____
(L)	Required Length of Run	_____ Km
(A)	Minimum Optical Power Required for _____ Receiver	_____ dBm    Average    _____ Peak
(R)	Receiver Dynamic Range	_____ dB
	Maximum Optical Power Allowed at Receiver (A+R)	_____ dBm
	Transmitter Type (Wavelength)	_____ nm    Laser Diode (nm)    _____ Other Source (nm)    _____

	Source-to-Fiber Coupling: Fiber (Core Diameter)	$\mu\text{m}$	$\mu\text{m}$	$\mu\text{m}$
(B)	Coupled Power (From Figure 26)	_____ dBm	_____ dBm	_____ dBm
(C)	Power Difference (B-A)	_____ dB	_____ dB	_____ dB
(D)	Degradation Allowance	_____ dB	_____ dB	_____ dB
(E)	Power Margin (C-D)	_____ dB	_____ dB	_____ dB
(F)	Connectors (Average Loss: _____ dB/Connector)	_____ dB	_____ dB	_____ dB
(G)	Splice (Average Loss: _____ dB/splice)	_____ dB	_____ dB	_____ dB
(H)	Maximum Cable Attenuation Allowed (E-F-G)	_____ dB	_____ dB	_____ dB
(I)	Cable Attenuation at 850 nm (From chart in Figure 26)	_____ dB/Km	_____ dB/Km	_____ dB/Km
(J)	Total Cable Loss (I x L)	_____ dB	_____ dB	_____ dB
	Maximum cable Length Allowed (H/I)	_____ Km	_____ Km	_____ Km
(K)	Excess Power Margin	_____ dB	_____ dB	_____ dB

## Worksheets (Continued)

### Step 4. Signal Bandwidth Analysis

#### Example:

Receiver Bandwidth PIN Type:  $BW_R = 10 \text{ Mhz}$   
 (A)  $1/BW_R^2 = 10^{-2} \text{ MHz}^{-2}$   
 Transmitter Bandwidth LED Type:  $BW_T = 20 \text{ Mhz}$   
 (B)  $1/BW_T^2 = 2.5 \times 10^{-3} \text{ MHz}^{-2}$   
 Fiber Optic Cable Bandwidth  
 (C) Fiber Length  $L = 2 \text{ Km}$

Fiber (Core Diameter Type)		200 $\mu\text{m}$	100 $\mu\text{m}$	62.5 $\mu\text{m}$
(D)	Bandwidth $BW_f$	25 MHz-Km	20 MHz-Km	200 MHz-Km
(E)	Cable Optical Bandwidth $BW_{CO}$	12.5 MHz	11.9 MHz	118.9 MHz
(F)	Cable Electrical Bandwidth $BW_C$ (E/1.41)	8.9 MHz	8.4 MHz	84.3 MHz
(G)	$1/BW_C^2$	$1.3 \times 10^{-2} \text{ MHz}^{-2}$	$1.4 \times 10^{-2} \text{ MHz}^{-2}$	$1.4 \times 10^{-2} \text{ MHz}^{-2}$
System Bandwidth				
(H)	Sum of Squares (A+B+G)	$2.5 \times 10^{-2} \text{ MHz}^{-2}$	$2.6 \times 10^{-2} \text{ MHz}^{-2}$	$1.3 \times 10^{-2} \text{ MHz}^{-2}$
(I)	System Bandwidth $1/\sqrt{H}$	6.3 MHz	6.2 MHz	8.8 MHz
(J)	Required System Bandwidth	1.0 MHz	1.0 MHz	1.0 MHz
(K)	Bandwidth Margin (I-J)	5.3 MHz	5.2 MHz	7.8 MHz

#### Worksheet:

Receiver Bandwidth\_\_Type:  $BW_R = \underline{\hspace{2cm}} \text{ Mhz}$   
 (A)  $1/BW_R^2 = \underline{\hspace{2cm}} \text{ MHz}^{-2}$   
 Transmitter Bandwidth\_\_Type:  $BW_T = \underline{\hspace{2cm}} \text{ Mhz}$   
 (B)  $1/BW_T^2 = \underline{\hspace{2cm}} \text{ MHz}^{-2}$   
 Fiber Optic Cable Bandwidth  
 (C) Fiber Length  $L = \underline{\hspace{2cm}}$

Fiber (Core Diameter Type)				
(D)	Bandwidth $BW_f$	MHz-Km	MHz-Km	MHz-Km
(E)	Cable Optical Bandwidth $BW_{CO}$	MHz	MHz	MHz
(F)	Cable Electrical Bandwidth $BW_C$ (E/1.41)	MHz	MHz	MHz
(G)	$1/BW_C^2$	$\text{MHz}^{-2}$	$\text{MHz}^{-2}$	$\text{MHz}^{-2}$
System Bandwidth				
(H)	Sum of Squares (A+B+G)	$\text{MHz}^{-2}$	$\text{MHz}^{-2}$	$\text{MHz}^{-2}$
(I)	System Bandwidth $1/\sqrt{H}$	MHz	MHz	MHz
(J)	Required System Bandwidth	MHz	MHz	MHz
(K)	Bandwidth Margin (I-J)	MHz	MHz	MHz

## Worksheets (Continued)

### Step 5. System Review

System Considerations	Example	Requirements for Operation
Data Rate (Bandwidth)	1.4 Mbps (1.0 MHz)	
Signal-to-Noise Ratio (Analog)		
Bit Error Rate (Digital)	$10^{-9}$	
Coding Scheme (Digital)	NRZ	
<b>Receiver</b>		
Type	PIN	
Bandwidth	10 MHz	
Sensitivity		
Minimum Optical Power	-39 dBm Average	
Bit Error Rate	$10^{-9}$	
Dynamic Range	20 dB	
<b>Transmitter</b>		
Bandwidth	20 MHz	
Coupled Optical Power	-5 dBm	
Wavelength/Type	850 nm/LED	
<b>Optical Fiber</b>		
Fiber Type	200 $\mu$ m core	
Bandwidth	25 MHz-Km	
Attenuation (at Transmitter Source Wavelength)	8 dB/Km	
Fiber Length	2 Km	
Number of Splices	0	
Total Splice Attenuation	0 dB	
Number of Connectors	2	
Total Connector Attenuation	6 dB	
Degradation Allowance	6 dB	
Bandwidth Margin	5.3 MHz	
Excess Power Margin	6 dB	

### Step 6. System Costs

The cost of each component should be totaled to determine the system cost.

_____	Connectors at \$ _____	/connector	= \$ _____
_____	Transmitters at \$ _____	/transmitter	= \$ _____
_____	Receivers at \$ _____	/receiver	= \$ _____
_____	Km of Cable at \$ _____	/kilometer	= \$ _____
_____	Repeaters at \$ _____	/repeater	= \$ _____
	Installation Costs		= \$ _____
	Maintenance Costs		= \$ _____
	Other Costs		= \$ _____
	Total System Costs		= \$ _____





**TERMS AND CONDITIONS,  
GLOSSARY OF TERMS,  
STANDARDS,  
AND  
WARRANTY**

## TERMS & CONDITIONS

### FOUR EASY WAYS TO ORDER:



**QUOTATIONS:** We strive to ensure that our products are competitively priced. For large quantities of any item, please call for a price quotation. All quotations made by S. I. Tech, Inc. ("Seller") for the sale of its products ("Products") are contingent upon Buyer's acceptance of these Terms and Conditions of Sale ("Terms") are subject to change if any modification or additions to the Terms are requested by the Buyer.

**ACCEPTANCE OF ORDERS:** All orders placed by Buyer are subject to acceptance by an authorized representative of Seller at Seller's principal offices at Batavia, Illinois. Any purchase order or other form or method used by buyer to order the Products shall be used for convenience only and shall evidence Buyer's unconditional acceptance of these Terms. Any terms and conditions contained in Buyer's purchase order which are inconsistent with, or in addition to, these Terms, shall not be binding upon Seller unless, and until, Seller agrees to any such terms, in writing, signed by an authorized representative of Seller. These Terms cannot be modified or waived except by written Agreement executed by an authorized representative of Seller at Seller's principal offices in Batavia, Illinois.

### PRICES:

- (a) Prices listed in Seller's quotations or acknowledgements, or which are quoted verbally by Seller will remain firm for Thirty (30) days (except as otherwise provided in paragraph 1, above) provided that the prices of Seller's vendors do not change during thirty (30) day period.
- (b) Payment terms for all Products are 2% - 10 days, net 30 days for USA customers. These payment terms are independent of, and are not contingent upon, the time and manner in which Buyer receives payment from any of its customers.
- (c) Cash discounts, if any, are applicable to Product only, excluding freight charges. No allowance will be made for C.I.A., C.O.D. or charge cards.
- (d) **A finance charge of 1.5% per month (annual percentage rate of 18%) will be charged on all past due amounts. In the event suit or other proceeding is brought by Seller for the recovery of the purchase price, or any Unpaid portion thereof, or for any breach of any other Term, Buyer shall pay to Seller, in addition to any Damages provided by law, all collection costs incurred by Seller, including reasonable attorney's fees.**
- (e) Prices quoted by Seller do not include applicable federal, state or local taxes or other charges. Buyer shall pay all such taxes, and other charges, together with any penalties and interest, and file any returns with respect thereto, upon receipt of any invoice from Seller. In lieu of payment of any such taxes, Buyer shall provide Seller with an acceptable tax exemption certificate. Buyer agrees to indemnify Seller, and hold Seller harmless, and upon request, defend Seller, against any and all assessments, demands, causes of action, suits, or claims of any nature, whatsoever, including costs and attorneys' fees, incurred by Seller in connection with the payment or nonpayment law or pursuant to this paragraph.

**SECURITY:** Seller shall have a security interest in all products sold to Buyer until full and complete payment has been received by Seller from Buyer for the Products. Buyer agrees to do all acts necessary to permit Seller to perfect and maintain such Security interest.

**FINANCIAL RESPONSIBILITY:** If, in sole judgment of Seller, Buyer's financial resources become impaired or unsatisfactory at any time prior to completion or shipment of Buyer's order, then Seller may, in its sole discretion: (a) cancel any such order, or any undelivered portion thereof; (b) resell, at any time, for Buyer's account, all or any undelivered portion of any of Buyer's order, in which case, if the resale price is less than the price at which buyer has ordered the products, Buyer agrees to pay Seller the difference; or (c) change the terms of payment herein specified. In the event Buyer becomes insolvent, or admits Buyer's inability to pay its debts as they mature, or if Buyer makes an assignment for the benefit of any of its creditors, or makes any general arrangement with creditors, or if there is instituted by, or against, Buyer any proceeding in bankruptcy or reorganization, receivership, or dissolution, Seller may immediately terminate any order of buyer, at any time, and without notice to Buyer.

**TOOLING:** Any special tools or fixtures required to manufacture any Product's ordered by Buyer shall become, and remain, Seller's sole property, notwithstanding any financial contribution that Buyer may have made with respect thereto.

**MINIMUM ORDER:** The minimum order is \$100.00. A package and handling charge will be added to every order.

**PAYMENT TERMS:** Terms are net 30 days for credit-approved customers. To open an account, call or send in the information requested on the credit application (see order form on reverse side). For your convenience, Visa, Master Card, American Express, Discover Cards are accepted.

**EVALUATIONS:** Certain products are available for a 30 day evaluation. Call for more information. If you are not satisfied, please call to obtain a return authorization. Return within 30 days of original shipment to avoid Restocking charges.

**RETURNS:** Call Customer Service to arrange a return and receive a return material authorization number. Returned items should be in mint condition and in the original package.

- A. Order in Error:** any customer may return a standard catalog product if it does not meet the intended application and the customer has consulted and received approval from S.I. Tech technical support within 10 days of invoice date.
- B. Return 30 Days:** Between 11 days and 30 days of invoice date, standard catalog products may be returned with 15% restock charge provided the product is in original condition and packaging with complete instructions and power cord(s).
- C. Return 60 days:** Between 31 and 60 days of invoice date, standard catalog products may be returned with 30% restock charge provided the product is in original condition and packaging with complete instructions and power cord(s).
- D. Custom Products:** No cancellations or returns available after order acceptance date. No returns of special or custom-built products ordered by Buyer, including copper or fiber optics data cable assemblies, will be accepted by Seller.

**DELIVERY AND SHIPMENT DATES:** Any dates and delivery schedules for delivery of Products stated in Seller's quotation or acknowledgment represent Seller's best estimate made at the time of quotation and are not binding upon Seller. **Seller shall have no liability, whatsoever, to Buyer, buyer's customers, or any third party for direct, liquidated, consequential, incidental or indirect damages, losses or expenses resulting from delays in shipment of the Products.**

**FREIGHT:** All shipments are F.O.B. Seller's manufacturing plant, located in Batavia, IL. 60510 USA

## GLOSSARY OF TERMS

<b>10BASE2</b>	An Ethernet standard that uses a thin coaxial cable. Also called Thin Ethernet. 10-Mbps baseband signal.
<b>10BASE5</b>	The original Ethernet Standard that uses a thick coaxial cable. Also called Thick Ethernet, 10-Mbps.
<b>10BASE-FL</b>	The portion of the 10BASE-F standard that defines a fiber optic link between a concentrator and station. Ethernet over fiber.
<b>100BASE-Tx</b>	A high-speed version of Ethernet (EEE 802.3). Also called Fast Ethernet, 100BASE-Tx transmits at 100 Mbps.
<b>100BASE-FX</b>	Fast Ethernet, 100 Mbps, IEEE 802.3 standard using fiber optics for communication.
<b>1000BASE-T</b>	1 Gigabit/Second with twisted pair, IEEE 802.3 standard.
<b>AC</b>	Abbreviation for <b>A</b> lternating <b>C</b> urrent.
<b>Access</b>	The ability to manipulate data, or to communicate with a computer resource.
<b>ADSL</b>	Asymmetric Digital Subscriber Line. A high-speed copper wire link that connects a Jetstream IAD to a DSLAM.
<b>Analog</b>	Representation of data that varies in a continuous manner. A voice signal.
<b>ANSI</b>	American National Standards Institute. Main standards development body in USA. ANSI participates in international standards (such as IEC) development on behalf of USA
<b>Amplitude</b>	The maximum value of a varying wave form.
<b>ASCII</b>	American Standard Code for Information Interchange. A coding scheme wherein letters, numbers, and special symbols are represented as unique 7-bit values, allowing for standardization between data communications devices.
<b>ASP</b>	Application Service Provider or Apple Talk Session Protocol
<b>Asynchronous Communication</b>	A serial stream of data sent as generated. Characters are delimited by start and stop bits whose function is to synchronize character bit timing.
<b>ATM</b>	Asynchronous Transfer Mode. A technology used for high-speed packet switching and transmission on a Broadband Integrated Services Digital Network (B-ISDN). ATM is designed to take advantage of high-speed transmission media.
<b>Attenuation</b>	The decrease in magnitude of a wave as it travels through any transmitting medium, such as a cable or circuitry. Attenuation is measured as a ratio or as the logarithm of a ratio (decibel).
<b>Audio Frequency</b>	That range of frequencies lying within the range of human hearing: approximately 20 to 20,000 Hz.
<b>AUI</b>	Abbreviation for Attachment Unit Interface, used with Ethernet.
<b>Auto Negotiation</b>	In case of Ethernet network (LAN), automatically selects 10, 100 or 1000 Mbps network operating speed.
<b>Balanced Line</b>	A cable having two identical conductors with the same electromagnetic characteristics in relation to other conductors and to ground.
<b>Balun</b>	A device for matching an unbalanced coaxial transmission line to a balanced two-wire system. Normally gives impedance transformation, e.g. 100 ohm balanced to 75 ohm unbalanced.
<b>Bandwidth</b>	The difference between the upper and lower limits of a given band of frequencies. Usually expressed in Hertz. In fiber optics, it is expressed as MHz/Km
<b>Baseband</b>	The frequency band occupied by a single or composite signal in its original or unmodulated form.
<b>Baseband Lan</b>	A local area network using baseband signaling.

<b>Baud</b>	A unit of signaling speed equal to the number of signal events per second.
<b>Bend Loss</b>	A form of increased attenuation caused by (a) having the fiber curved around a restrictive radius of curvature or (b) microbends caused by minute distortions in the fiber imposed by externally induced perturbations.
<b>Bend Radius</b>	Radius of curvature that a fiber optic cable can bend without any adverse effects.
<b>Bert</b>	Bit error rate in digital system.
<b>Bridge</b>	A device that connects two LAN segments together, which may be of similar or dissimilar types, such as Ethernet and Token Ring.
<b>Bluetooth</b>	A short range wireless standard used as a substitute for wire or fiber in portable devices such as cell phones, PDAs or laptop PCs operates in 2.4 GHz range
<b>Buffer</b>	A protective coating over the fiber.
<b>Broadband</b>	A technique for sending data, voice, video information over long distances by sending high frequency signals over coax, UTP, fiber optic cable or wireless.
<b>Carrier Frequency</b>	The electromagnetic wave frequency selected to transmit information. Optical carrier frequency is from the infrared, visible or ultraviolet spectrum areas (1012 Hz and above).
<b>CE</b>	European Union standard applicable to electronic, data communication and other products, EMI/RFI compliance requirements.
<b>Cladding</b>	A low refractive index material that surrounds the core and provides optical insulation and protective of the core.
<b>CLEC</b>	Competitive (or Certified) Local Exchange Carrier. A company that offers local exchange services to end users.
<b>Component Video</b>	An analog video signal in which the luminance and chrominance is carried on 3 lines – Y, Pb, Pr.
<b>Composite Video</b>	Analog video only (No audio) part of a TV signal that mixes Red, Green, Blue and Sync signal on one wire. Applicable standards are NTSC, PAL and SECAM.
<b>Controller</b>	A component of a computer system that directs data traffic within the system.
<b>Core</b>	The light transmission part of the fiber with a refractive index higher than that of the cladding.
<b>CoS</b>	(Class of Service)
<b>C.S.A.</b>	Abbreviation for Canadian Standards Association.
<b>CSMA/CD</b>	Carrier sense multiple access with collision detection, used in Ethernet.
<b>Current Loop</b>	A two wire transmit/receive interface.
<b>Daisy Chain</b>	A connection technique where components are attached in a serial fashion.
<b>Data Communications</b>	Movement of data messages to and from remote system through a medium.
<b>Data Compression</b>	The “squeezing” of data for the purpose of throughput. This squeezing can be done on a character basis by reducing the character size of transmitted and received characters, or on a message basis by eliminating redundant characters.
<b>Data Rate</b>	A measure of the signal rate of a data link.
<b>DCE</b>	Abbreviation for Data Circuit Terminating Equipment. Carrier equipment, installed at the user’s premises that provides all the functions required to establish, maintain, and terminate a connection, and which provides the signal conversion and coding between the data terminal equipment and the common carrier’s line.
<b>Decibel (dB)</b>	One-tenth of a bel. It is equal to 10 times the logarithm of the power ratio, 20 times the log of the voltage ratio, or 20 times the log of the current ratio. One decibel is the amount by which the pressure of a pure sine wave of sound must be varied in order for the change to be detected by the average human ear. The decibel can express an actual level only when comparing with some definite reference level that is assumed to be zero dB.

<b>Dedicated</b>	Committed to one specific use, such as a dedicated port on a computer to a specified terminal or microcomputer.
<b>Degradation</b>	Deterioration in the quality or speed of data transmission, caused as more users access a computer or computer network.
<b>Dispersion</b>	The cause of bandwidth limitations in a fiber. Dispersion causes a broadening of input pulses along the length of the fiber. Two major types are (a) mode dispersion caused by differential optical path lengths in a multimode fiber, and (b) material dispersion caused by a differential delay of various wavelengths of light in a wave guide material.
<b>Digital</b>	Representation of data by discrete characters (1's and 0's), e.g. 0 or 1
<b>DS3</b>	The DS3 port adapter is used for wide-area connectivity, to link multiple campuses, or to connect to public networks. The DS3 port adapters supports standard BNC coaxial cable connectors.
<b>DSL</b>	Digital Subscriber Line. A technology that uses copper wire pairs for high-speed transmission of voice and data.
<b>DSLAM</b>	Digital Subscriber Line Access Multiplexer.
<b>DTE</b>	Abbreviation for Data Terminal Equipment. The end-user machine, be it terminal, computer, controller, etc., that plugs into a unit that is the termination point of a communications circuit (DCE).
<b>DVI</b>	Digital visual interface – a high performance interface between a computer and a display device.
<b>E1</b>	The European standard for high speed digital transmission at 2048 Mbps.
<b>EBCDIC</b>	Extended binary coded decimal interchange code. A coding scheme wherein letters, numbers and special symbols are represented as unique 8-bit values, allowing for standardization between data communications devices; popularized by IBM.
<b>EIA</b>	Electronic Industries Association (formerly RMA or RETMA).
<b>Echo</b>	Data communications devices typically can be informed that they are to return to the sender all received characters. This is known as echoing characters and can be used to provide positive feedback to the initiator.
<b>Electromagnetic</b>	Referring to the combined electric and magnetic fields caused by electron motion through conductors.
<b>Electromagnetic Coupling</b>	The transfer of energy by means of a varying electrostatic field. Capacitive coupling.
<b>EMF</b>	Abbreviation for Electromotive Force (voltage).
<b>EMI/RFI</b>	Electromagnet interference/Radio frequency interference.
<b>Emulation</b>	Referring to “acts like”. In computer equipment an emulation card makes a PC resemble a certain mainframe or mini-computer to another device.
<b>Encryption</b>	A security feature that changes data so it can be read only by intended receiver.
<b>Ethernet</b>	A baseband local area network specification developed jointly by Xerox Corp., Intel Corp., and Digital Equipment Corp. (DEC) to interconnect computer equipment using coaxial cable, twisted pairs and transceivers.
<b>FCC</b>	Federal communication commission.
<b>Fiber</b>	A single, separate optical transmission element characterized by a core and a cladding.
<b>Fiber Channel</b>	A high speed storage protocol describing an interface used in SANs to connect servers to share storage.
<b>Fiber Optics</b>	Light transmission through optical fibers for communication or signaling.
<b>Firewall</b>	A network node set up as a boundary to prevent one segment'

<b>FM</b>	Frequency Modulation.
<b>FOIRL</b>	(Fiber Optic InterRepeater Link): An IEEE standard for fiber optic Ethernet.
<b>Frame Relay</b>	A packet-switched network similar to X.25 but with end-to-end error-checking and high-speed transmission rates.
<b>Frequency</b>	The number of times a periodic action occurs in a unit of time. The number of cycles that an electric current completes in 1 second.
<b>Frequency Response</b>	The characteristic of a device denoting the range of frequencies over which it may be used effectively.
<b>Full-Duplex Transmission</b>	Allows for simultaneous bi-directional movement of data communications.
<b>Gateway</b>	A special node that interfaces two or more dissimilar networks, providing protocol translation between the networks.
<b>Gigahertz (GHz)</b>	A unit of frequency equal to one billion hertz.
<b>Graded Index</b>	A type of fiber where the refractive index of the core is lower toward the outside of the fiber. It bends the rays inward and also allows them to travel faster in the lower index of refraction region. This type of fiber provides high bandwidth capabilities.
<b>Ground Loop</b>	A completed circuit between shielded pairs of multiple pair cable created by random contact between the shields. An undesirable circuit condition in which interference is created by ground currents when grounds are connected at more than one point.
<b>Half-Duplex</b>	Allows for movement of communications in both directions, but in a single direction only at any point in time.
<b>HDLC</b>	High-level Data Link Control. The International Standards Organization's physical link protocol. Various manufacturers have their own derivative of HDLC, the most common of which is IBM's SDLC (Synchronous data link control).
<b>HDMI</b>	High definition multimedia interface to combine high definition video, multichannel audio and intelligent format and command data in one cable.
<b>Head-End</b>	A central point in broadband networks that receives signals on one set of frequency bands and retransmits them on another set of frequencies. Viewed as a central hub.
<b>Hertz</b>	The unit of frequency, one cycle per second.
<b>Host Computer</b>	The primary of controlling computer in a multiple computer operation upon which the smaller computers depend to do most work.
<b>Hot Spot</b>	A public place in which an access point provides wireless broadband network service to wireless – equipment thru' WLAN.
<b>IAD</b>	Integrated Access Device. A device that supports voice, data and video streams over a single, high-capacity circuit.
<b>IEEE-488</b>	Institute of Electrical and Electronic Engineers 488. An IEEE standard parallel interface bus consisting of eight bi-directional data lines and eight signal grounds, which provides for connection to an IEEE-488 device.
<b>IEEE-802</b>	Standards for the interconnection of local area networking computer equipment. It deals with the Physical and Link Layers of the ISO/OSI reference model.
<b>ILEC/PPT</b>	Incumbent Local Exchange Carrier
<b>Impedance</b>	The total opposition a circuit, cable or component offers to alternating current. It includes both resistance and reactance and is generally expressed in ohms.
<b>Impedance Characteristic</b>	In a transmission cable of infinite length, the ratio of the applied voltage to the resultant current at the point the voltage is applied. Or, the impedance which makes a transmission cable seem infinitely long, when connected across the cable's output terminals. For a wave guide, it is the ratio of rms voltage to total rms longitudinal current at certain point on a diameter, when the wave guide is

	match terminated.
<b>Inductance</b>	A property of a conductor or circuit which resists a change in current. It causes current changes to lag behind voltage changes and is measured in henrys.
<b>Injection Laser Diode (Source)</b>	Sometimes called the semiconductor diode. A laser in which the lasing occurs at the junction of n-type and p-type semiconductor materials.
<b>Interface</b>	The place where two systems or a major and a minor system meet and interact with each other.
<b>Interference</b>	Disturbances of an electrical or electromagnetic nature that introduce undesirable responses into other electronic equipment.
<b>Internet</b>	The worldwide computer network used for reference, e-mail, and other services.
<b>Intranet</b>	A network that connects a related set of standard Internet protocols and files in HTML format with employees using Internet browsers in an organization's network and with in corporate firewalls.
<b>IP (Internet Protocol)</b>	The protocol used in gateways to connect networks at the OSI Network Level (Layer T3 ) and above. IP routes a message across networks.
<b>IPSEC (IP Security)</b>	An IETF working group tasked with developing standards for security protocols to provide IP security services that will support combinations of authentication, integrity, access control and confidentiality.
<b>ISDN</b>	Integrated Services Digital Network: Communication protocol, offered by telephone companies that permits telephone networks to carry data, voice, and other source traffic.
<b>ISO/OSI Reference Model</b>	The International Standards Organization Reference Model for Open Systems interconnection. A standard approach to network design that introduces modularity by dividing the complex set of functions into more manageable, self-contained, functional slices.
<b>Isolation</b>	The ability of a circuit or component to reject interference, usually expressed in dB.
<b>IXC</b>	Inter-Exchange Carrier. These are typically long-distance phone companies.
<b>KPSI</b>	Tensile strength in thousands of pounds per square inch.
<b>Laser</b>	A coherent source of light with a narrow beam and a narrow spectral bandwidth.
<b>Line Driver</b>	A power amplifier for local data transmission.
<b>Link</b>	The combination of communication devices, media and software intelligence that is required to effect data.
<b>Light-Emitting Diode</b>	A semiconductor device that emits incoherent light formed by the P-N junction. Light intensity is roughly proportional to electrical current flow.
<b>Local Area Network (LAN)</b>	A network that is located in a localized geographical area, such as an office, building, complex of buildings or campus, with communications technology that provides a high-bandwidth, low-cost medium to which many nodes can be connected.
<b>Megahertz (Mhz)</b>	Unit of frequency equal to one million hertz.
<b>Micron</b>	Millionth of a meter= $10^{-6}$ meter.
<b>Mode</b>	A permitted electromagnetic field pattern within an optical fiber.
<b>Modem</b>	Device that converts signals in one form to another form compatible with another kind of equipment. (Modulator – demodulator)
<b>Modular</b>	A style of easily connected or disconnected components.
<b>Modulation</b>	The coding of information onto the carrier frequency. Modulation means include (among others) amplitude, frequency, or phase, plus many forms of on-off digital coding.
<b>MPLS</b>	Multiprotocol Label Switching traffic engineering software enables an MPLS backbone to replicate and expand upon the traffic engineering capabilities of Layer 2 ATM and Frame Replay networks.

<b>Multiplex</b>	Placing two or more signals into a single channel.
<b>Multiplexing</b>	The use of common physical channel to make two or more logical channels, either by splitting the frequency band transmitted by the common channel into narrower bands, each of which is used to constitute a distinct channel (frequency division multiplex), or by allotting this common channel in turn to constitute different, intermittent channels (time division multiplex).
<b>Multiplexer</b>	Equipment that permits simultaneous transmission of multiple signals over one physical circuit.
<b>Multi-tasking</b>	The sharing of routines, data space and files to execute several jobs at once.
<b>Nanometer (nm)</b>	One billionth of a meter $10^{-9}$ meter.
<b>NEC</b>	National Electrical Code.
<b>Network</b>	A logical arrangement of data communications devices and software whose purpose is to provide data processing capabilities to end users at optimal efficiency.
<b>Network Interface Controller</b>	A communications device that allows interconnection of information processing devices to a network.
<b>Network Management</b>	Administrative services performed in managing a network, such as network topology and software configuration, downloading of software, monitoring network performance, maintaining network operations, and diagnosing and troubleshooting problems.
<b>Nibble</b>	One half byte (4 bite)
<b>Node</b>	Interface unit, or station, that contains logic for measuring the flow of network traffic that passes through it. May be connected to more than one device.
<b>Noise</b>	In a cable or circuit, any extraneous sound or signal which tend to interfere with the sound or signal normally present in or passing through the system.
<b>Null Modem</b>	A device that connects two DTEs directly by emulating the physical connections of DCE.
<b>Numerical Aperture (NA)</b>	A measure of the angular acceptance for a fiber. It is approximately the size of the half-angle of the acceptance cone. $NA = \sqrt{n_1^2 - n_2^2}$ Where $n_1$ and $n_2$ are respectively, the refractive index of the core and the cladding.
<b>OC-1 (Optical Carrier Level 1)</b>	The lowest optical-transmission rate in the SONET standard, 51.48 Mbps.
<b>OC-3</b>	155 Megabit per second connection often associated with an ATM or Packet over SONET link.
<b>Octopus Cable</b>	A fan-out cable with multiple baluns and one 25 pair telco connector.
<b>Ohm</b>	The electrical unit of resistance. The value of resistance through which a potential difference of one volt will maintain a current of one ampere.
<b>ONS</b>	(Optical Networking System)
<b>Optical Waveguide Fiber</b>	A transparent filament of high refractive index core <i>and</i> low refractive index cladding that transmits light.
<b>PABX</b>	Private Automatic Branch Exchange. Equipment originally used as a means of switching telephone calls within a business site and from the site to outside lines. Can also be used for low-speed transmission of data in addition to voice.
<b>Packet</b>	A collection of bits that contain both control information and data. The basic unit of transmission in a packet-switched network. Control information is carried in the packet, along with the data; to provide for such functions as addressing, sequencing, flow control, and error control at each of several protocol levels. A packet can be of fixed or variable length but generally has a specified length.
<b>Packet Format</b>	The exact order and size of the various control and information fields of a packet, including header, address and data fields.



<b>Packet Overhead</b>	A measure of the ratio of total packet bits occupied by control information to the number of bits of data, usually expressed as a percent.
<b>Packet Switching</b>	A method in which data is transmitted in addressed packets and a transmission channel is only occupied for the duration of packet transmission. The channel is then available for use by packets being transferred between different data terminal equipment.
<b>Parity</b>	The integrity of each character transmitted over a communications link can be tested by generation and subsequent checking of character parity. Computed using the bit-wise “or” of the character bits and added a bit to get an even or odd results.
<b>Phase</b>	The location of a position on a waveform of an alternating quality, in relation to the start of a cycle. Measured in degrees, with 360 corresponding to one complete cycle.
<b>Phase Shift</b>	A change in the phase relationships between two alternating quantities.
<b>POE</b>	Power over Ethernet.
<b>Photo detector (receiver)</b>	Transforms light into electricity. The silicon photo diode is most commonly used for relatively fast speeds and good sensitivity in the 0.75 $\mu\text{m}$ to 0.95 $\mu\text{m}$ wavelength region. Avalanche photodiodes (APD) combines the detection of optical signals with internal amplification of photocurrent. The internal gain is realized through avalanche multiplication of carriers in the junction region. The advantage in using an APD is its higher signal-to-noise ration, especially at high bit rates.
<b>Pin-diode</b>	A photodetector used to convert optical signals to electrical signals in a receiver.
<b>Point-to-point</b>	Transmission of data between only two nodes, one sender and one receiver.
<b>Polling</b>	The continuous checking of device status. A method of controlling the transmission sequence by requiring each device on a multipoint line to wait until the controlling processor requests it to transmit.
<b>PoP (Point of Presence)</b>	In OSS, a physical location where an interexchange carrier has installed equipment to interconnect with an LEC (local exchange carrier).
<b>Propagation Delay</b>	Time required for a signal to pass from the input to the output of a device.
<b>Protocol</b>	A set of rules and conventions that governs the orderly and meaningful exchange of information between or among communicating parties. Hardware and software protocols can be defined.
<b>Protocol Converter</b>	A device for translating the data transmission code and/or protocol of one network or device to the corresponding code or protocol of another network or device, enabling equipment with different conventions to communicate with one another.
<b>Public Data Network (PDN)</b>	A packet-switched or circuit-switched network that is available for use by many customers. A PDN may offer value-added services at a reduced cost because of communications resource sharing, and it will usually provide increased reliability due to built-in redundancy.
<b>QoS (Quality of Service)</b>	Measure of performance for a transmission system that reflects its transmission quality and service ability.
<b>Receiver</b>	An electronic package that converts the optical signal to an electrical signal.
<b>Refractive Index</b>	The ratio of light velocity in a vacuum to its velocity in the transmitting medium.
<b>Repeater</b>	Bi-directional device that amplifies or resynchronizes signals into standard voltages, currents and timing.
<b>Resistance</b>	In dc circuits, the opposition a material offers to current, measured in ohms. In ac circuits, resistance is the real component of impedance and may be higher than the value measured at dc.

<b>Response Time</b>	The interval between the execution of a command or inquiry at a terminal and the subsequent receipt of a response at the same terminal.
<b>Ring</b>	A network topology in which stations are connected to one another in a closed, logical circle. Typically, access to the media passes sequentially from one station to the next by means of polling from a master station, or by passing an access token from one station to another.
<b>ROHS</b>	.Restriction of hazardous substances – European Union (EU) directive banning use of six hazardous materials in electrical and electronic equipment.
<b>Router</b>	A computer system that stores and forwards data packets by way of network address between LANs and WANS.
<b>RS-232C</b>	A technical specification that specifies mechanical and electrical characteristics of the interface for connecting DTE to DCE. It defines interface circuit functions and their corresponding connector pin assignments. The standard applies to both a synchronous and synchronous serial binary data transmission at speeds up to 20 kilobits per second in half- or full-duplex mode. It defines 20 specific functions and the physical connection is made through plug-in, 25-pin connectors.
<b>RS-422</b>	A standard operating in conjunction with RS-449 that specifies the electrical characteristics for balanced circuits, that is, circuits with their own ground leads.
<b>RS-449</b>	A standard for DTE/DCE connection that specifies interface requirements for expanded transmission speeds, up to 2 megabits per second (Mbps), longer cable lengths, and 10 additional functions. It applies to binary, serial, asynchronous and synchronous communication in half- or full-duplex mode. The physical connection is made through a 37-contact connector; a separate 9-contact connector is specified to service secondary channel interchange circuits when used.
<b>RS-485</b>	A standard which specifies electrical characteristics of generators and receivers for use in balanced multiport systems.
<b>RS-530</b>	Similar to RS-449, uses DB25 connector and supports RS-422, RS-423, RS-485 and V.35.
<b>SAN</b>	Storage area network – a network of storage devices.
<b>SDH</b>	(Synchronous Digital Hierarchy)
<b>SDLC</b>	(Synchronous Data Link Control): IBM computer networking protocol associated with SNA. It provides for a control of a single communications link or line, accommodates a number of networking arrangements, and operates in half- or full-duplex over private or switched facilities.
<b>Serial Interface</b>	An interface requiring serial transmission or the transfer of information in which the bits composing a character are sent sequentially.
<b>Serial Transmission</b>	Transmission of one bit at a time.
<b>Server</b>	A processor that provides a specific service to the network. An example is a file server, which provides an interface between compatible peripheral devices on a LAN.
<b>SFP</b>	Small form factor pluggable optical transceiver.
<b>Simplex Communications</b>	Allows movement in a single direction only.
<b>Single-Ended</b>	Unbalanced, such as grounding one side of a circuit or transmission line.
<b>Single Mode Fiber</b>	A fiber wave-guide in which only one mode will propagate. The fiber has a very small core diameter of approximately 8µm. It permits signal transmissions at extremely high bandwidths and is generally used with laser diodes.
<b>Skew Rays</b>	A ray that does not intersect the fiber axis. Generally, a light ray that enters the fiber core at a very high angle.
<b>SNA</b>	Systems Network Architecture: Network for moving IBM mainframe data.

<b>Source</b>	The means (usually LED or laser) used to convert an electrical information-carrying signal into a corresponding optical signal for transmission by an optical wave-guide.
<b>Spectral Bandwidth</b>	The difference between wavelengths at which Bandwidth the radiant intensity of illumination is half its peak intensity.
<b>Speed of Light (c)</b>	2.998 X 10 <sup>8</sup> meters per second.
<b>Splicing</b>	permanent joining of identical or similar fiber ends without a connector.
<b>Star</b>	A network topology consisting of one central node with point-to-point links to several other nodes. Control of the network is usually located in the central node or switch, with all routing of network message traffic performed by the central node.
<b>Start Bit</b>	Serial asynchronous data transmission relies upon the start bit to signify to the receiver that a character follows. The start bit is longer in duration than normal data bits, and this extended length allows it to be distinguished from normal data bits.
<b>Station</b>	A network node.
<b>Step-Index Fiber</b>	A fiber in which the core is of a uniform refractive index and there is a sharp decrease in the index of refraction at the cladding.
<b>Stop Bit(s)</b>	Serial asynchronous data transmission relies upon the stop bit(s) to signify to the receiver that no more data bits follow. Stop bits are longer in duration than normal data bits and this extended length allows them to be distinguished from normal data bits. Serial communications may be configured to allow for either 1, 1.5, or 2 stop bits (however, the most common number is 1).
<b>T1</b>	A digital carrier facility used to transmit a DS-1 formatted digital signal at 1-544 Mbps. (24 voice channels at 64 Kbps)
<b>Tap</b>	A Device in the feeder cable that connects a device to a network.
<b>TCP/IP</b>	Transmission control protocol/Internet protocol. A specification that conforms to the latest Department of Defense Arpanet standard. The protocol corresponds to layers three and four of the ISO/OSI model.
<b>TDM</b>	Time Division Multiplexing. A method of using channel capacity efficiently, in which each node is allotted a small time interval, in turn, during which it may transmit a message or portion of a message. Nodes are given unique time slots during which they have exclusive command of the channel. The messages of many channels are interleaved for transmission and then de-multiplexed into their proper order at the receiving end.
<b>Terrabits</b>	1 Trillion Bits
<b>Throughput</b>	The total useful information processed or communicated during a specified time period. Expressed in bits per second or packets per second.
<b>Token Bus</b>	A network with a bus or tree typology using token passing access control.
<b>Token Passing</b>	A method whereby each device on a local area network receives and passes the right to use the channel. Tokens are special bit patterns or packets, usually several bits in length, which circulate from node to node when there is no message traffic. Possession of the token gives exclusive access to the network for message transmission.
<b>Token Ring</b>	The token access procedure used on a network with a sequential or ring topology.
<b>Topology</b>	Network topology can be centralized or distributed. Centralized networks, or star-like networks, have all nodes connected to a single node. Alternative topology is distributed; that is, in the limit each node is connected to every other node. Typical topology names include bus, ring, star, and tree.
<b>Traffic</b>	The measurement of data movement, volume, and velocity over a communications link.

<b>Transceiver</b>	A device required in baseband networks that takes the digital signal from a computer or terminal and imposes it on the baseband medium.
<b>Transceiver Cable</b>	Cable connecting the transceiver to the network interface controller, allowing nodes to be placed away from the baseband medium.
<b>Transmission Line</b>	An arrangement of two or more conductors or a wave-guide used to transfer signal energy from one location to another.
<b>Transmission Medium</b>	The physical mechanism that allows for signals to be passed from one data communications device to another.
<b>Transmitter</b>	The electronic package that converts an electrical signal to an optical signal.
<b>Transparency</b>	A data communications mode that enables equipment to send and receive bit patterns of any form, without regard to interpretation as control characters. The user is unaware that this is taking place.
<b>Trunk Cable</b>	See Feeder Cable.
<b>U.L.</b>	Underwriters Laboratories, Inc.
<b>Unbalance Line</b>	A transmission line in which voltages on the two conductors are unequal with respect to ground, e.g., a coaxial cable.
<b>USB</b>	Universal Serial Bus – used for attaching peripherals to computers(PCs)
<b>Velocity of Propagation</b>	The transmission speed of an electrical signal down a length of cable compared to speed in free space. Usually expressed as a percentage.
<b>VLAN</b>	Virtual LAN – a group of devices on a LAN or LANs that are configured for communications as if they were attached to the same wire, when in reality they are on a number of different LAN segments.
<b>VoDSL</b>	(Voice over Digital Subscriber Line)
<b>VoIP</b>	(Voice over Internet Protocol)
<b>VPN (Virtual Private Network)</b>	An encrypted connection between private networks over a public network, such as the Internet.
<b>WAN</b>	(Wide Area Network)
<b>WDM</b>	(Wavelength Division Multiplexing)
<b>Wave Form</b>	A graphical representation of a varying quantity. Usually, time is represented on the horizontal axis, and the current or voltage value is represented on the vertical axis.
<b>Wavelength</b>	The distance between the nodes of a wave. The ratio of the velocity of the wave to the frequency of the wave.
<b>WEEE</b>	Waste Electrical and Electronic Equipment directive of European Union controls regarding end of life disposal and recycling of equipment.
<b>WI-FI</b>	Wireless fidelity, refer to IEEE 802.11 standard for WI-FI network
<b>WI-MAX</b>	Wireless broadband network, refer to IEEE 802.16 standard. World wide Interoperability for microwave access.
<b>WLAN</b>	Wireless LAN
<b>X.25</b>	A CCITT (Consultative Committee on International Telegraphy and Telephone) standard that defines the interface between a public display network (PDN) and a packet-mode user device (DTE). It also defines the services that these user devices can expect from the X.25 PDN, including the ability to establish virtual circuits through a PDN to another user device, to move data from one user device to another, and to destroy the virtual circuit when through.
<b>XDSL</b>	Group term used to refer to ADSL, HDSL, SDSL and VDSL. All are digital technologies using the existing copper infrastructure provided by the telephone companies. XDSL is a high-speed alternative to ISDN.

## STANDARDS

**ISO 9001: *International Standards Organization*** issues a series of international standards, ISO 9001, which require documented systems for controlling the processes used to develop and produce products. S.I. Tech is quality certified by one of the leading registrars in the world, NSF, Inc. This quality assurance system covers contract review, design, development, purchasing production, installation, inspection and servicing. S.I. Tech follows the quality policy of “total customer satisfaction.”

**EIA: *Electronic Industry Association*** publishes many commonly used data communications standards.

RS-170 – CCTV video transmission quality

RS-232 – Interface between data terminal equipment (DTE) and data communications equipment (DCE).

Employing serial binary data interchange. (V.24 & V.28, ISO 2110).

RS-422 – Electrical characteristics of balanced voltage digital interface circuits.

RS-423 – Electrical characteristics of unbalanced voltage digital interface circuits.

RS-449 – Digital interface circuits for longer distances.

RS-485 – Electrical characteristics of balanced digital multipoint systems.

RS-530 – High Speed, DB25 connector interface for data terminal equipment (DTE) and data circuit terminating equipment. Supports RS422/423/485 and V.35.

**IEC: *International Electrotechnical Commission*** publishes many data communications standards used throughout the world. (Also CCITT – Consultative Committee for International Telephone and Telegraph)

V.21 – General purpose interface between DTE and DCE for synchronous operation on telephone networks.

V.24 – List of definitions for interchange circuits between DTE and DCE (RS-232).

V.27 – 4800 BPS modem for leased circuits.

V.28 – Electrical characteristics for unbalanced double current interchange circuits (RS-232).

V.29 – 900 BPS modem for leased circuits

V.35 – Data transmission at 48 KBPS

**IEEE: *Institute of Electrical and Electronics Engineers*** develops many standards.

IEEE 488 – Standard defines the digital interface for programmable instrumentation.

IEEE 802.1 – Relationship between IEEE and ISO model

IEEE 802.2 – Network control protocol

IEEE 802.3 – Ethernet Local Area Network

IEEE 802.4 – Map/Top Local Area Network

IEEE 802.5 – Token Ring Local Area Network

IEEE 802.6 – MAN Network

IEEE 802.7 – Broad Band Local Area Network

IEEE 802.8 – Fiber Optic CSMA/CD

IEEE 802.9 – Integrated Voice and Data

IEEE 802.10 – Interoperable LAN/WAN Security

IEEE 802.11 – Wireless LAN (WI-FI)

IEEE 802.12 – Repeater Specs

IEEE 802.14 – Cable TV Based Broadband Network

IEEE 802.15 – Wireless Personal Area Networks (WPANs)

IEEE 802.16 – Broadband wireless Network (WIMAX)

C37.90.1 – Surge withstand capability

IEC 801 – Surge Protection Standard

**UL: *Underwriters Laboratory*** covers safety related issues as they apply to data communications devices, e.g. standards 478 and 1950. Many S.I. Tech products are UL approved and labeled.

**CSA: *Canadian Standards Association*** also publishes safety related guidelines for data communication products, e.g. standard C22.2 and 950.

**FCC: Federal Communications Commission** is primarily concerned with radio, TV, (RFI/EMI) and other electronic devices and noise problems. It publishes dockets (rules) regarding conducted, emitted and radiated noise. Class A, part 15 applies to computing devices for industrial and office use. Class B, part 15 applies to computing devices in homes. S.I. Tech products meet Class A, part 15 requirements.

**VDE: West German Standards.** Some are similar to IEC, EIA, UL and other standards. However, some are more stringent and different. Power supplies used in many S.I. Tech products meet VDE requirements.

**CE: European Regulatory Requirements** regarding EMC/EMI/RFI, etc.

**Military: U.S. military agencies** publish communications products standards, e.g. MIL-STD-188, MIL-STD-1552 and Tempest. S.I. Tech offers products meeting MIL-STD-188 and Tempest.

**TIA: Telecommunication Industry Association** publishes telecom standards

**T-1 (DS-1)** Trunk Level 1, basic protocol (1.54 Mbps) used by telecommunications companies for long distance communications in North America.

**T-3 (DS-3)** Digital signal communication protocol running at 44.736 Mbps, used by telecommunications carriers and high speed internet communications in North America.

	Sonet standards are used for synchronous optical networks, numbered OC-1 to OC-768
<b>STS-1 (OC-1)</b>	51.84 Mbps
<b>OC-3</b>	156 Mbps
<b>OC-12</b>	622 Mbps
<b>OC-48</b>	2.5 Gbps
<b>OC-192</b>	10 Gbps
<b>OC-768</b>	40 Gbps

**CCITT: Consultative Committee for International Telephone & Telegraph** published telecom standards.

<b>E-1</b>	2.048 Mbps Digital Service
<b>E-3</b>	34.368 Mbps Signal Carries 16 E1 Circuits

**USB: Universal Serial Bus Standard**, Describes connection of PC to peripherals.

- 1.1** – Runs at 1.5 or 12 Mbps
- 2.0** – Runs at 480 Mbps
- 3.0** – Under development, expected to run at 4.8 Gbps

**ROHS: Restriction of hazardous substances** – European Union [EU] directive banning use of six hazardous materials in electrical and electronic equipment.

**WEEE: Waste Electrical and Electronic Equipment.** European Union directive regarding “End of Life” disposal and recycling of equipment.

## WARRANTY

Seller warrants that the copper and fiber optics data cable assemblies which it manufactures will be free from defects in material and workmanship for a period of thirty (30) days from delivery. Seller warrants that all other Products which it manufactures will be free from defects in material or workmanship for a period of one (1) year from the date of delivery. In the event any product is not warranted, Seller's sole obligation, and Buyer's exclusive remedy, is as hereinafter provided. Buyer can also purchase extended warranty.

If, within the warranty period, Buyer discovers a defect in materials or workmanship which interferes with the electrical/optical operation of any Product manufactured by Seller, Buyer must promptly notify Seller, in writing, of such defect. Seller's sole obligation to Buyer under this warranty is to repair and correct any defect in material or workmanship. Seller's decision with respect to the applicability of this warranty to any defect shall be final and conclusive. Seller reserves the right to require Buyer, at Buyer's sole cost and expense, to return any Product, including any alterations made thereto, to Seller's manufacturing plant at Batavia, Illinois. Buyer may not return copper or fiber optics data cable assemblies for credit.

Seller is not liable to buyer or any other person for work done, apparatus furnished, or repairs made to remedy any defect by any person who is not an authorized representative of Seller unless Seller's written consent is first obtained by Buyer. This warranty does not apply to, and is rendered null and void by, and Product which, after leaving Seller's manufacturing plant is: (a) repaired or altered without Seller's prior written approval; or (b) is the subject of improper storage, installation or operation; or (c) is the subject of intentional or negligent misuse, misapplication, neglect, or accident; (d) is not used, repaired or altered in accordance with Seller's instructions.

This warranty does not apply to any goods, or part thereof, which are not manufactured by Seller. Any such goods shall be warranted only to the extent of the express warranty, if any, provided by the manufacturer of such goods.

Seller expressly reserves the right to declare this warranty null and void upon Buyer's failure to make full and timely payments with respect to any Products purchased by Buyer from Seller, whether under this order or any other order, in which event all of Seller's obligations, and Buyer's rights, hereunder, shall immediately terminate.

THIS WARRANTY IS MADE IN LIEU OF, AND BUYER WAIVES, ALL OTHER WARRANTIES, GUARANTEES, RIGHTS, OBLIGATIONS, UNDERSTANDINGS, REPRESENTATIONS AND REMEDIES, EXPRESS OR IMPLIED. ANY ORAL OR WRITTEN DESCRIPTION OF ANY PRODUCT MANUFACTURED BY SELLER, OR PART THEREOF, HAS BEEN MADE SOLELY FOR THE PURPOSE OF IDENTIFICATION AND ANY SUCH DESCRIPTION SHALL NOT MODIFY OR EXPAND THE EXPRESS WARRANTY MADE BY SELLER HEREUNDER. THE IMPLIED WARRANTIES OF MERCHANTABILITY AND FITNESS FOR A PARTICULAR PURPOSE ARE SPECIFICALLY DISCLAIMED BY SELLER AND EXCLUDED FROM ALL AGREEMENTS, WHETHER ORAL OR WRITTEN, MADE BETWEEN SELLER AND BUYER. THERE ARE NO UNDERSTANDINGS, REPRESENTATION OR WARRANTIES, EITHER EXPRESS OR IMPLIED, ARISING FROM THE COURSE OF PERFORMANCE, COURSE OF DEALING, USAGE OR TRADE. IN NO EVENT SHALL SELLER BE LIABLE UNDER THIS WARRANTY TO BUYER FOR DIRECT, SPECIAL, CONSEQUENTIAL, INDIRECT OR INCIDENTAL DAMAGES.

# **S.I. TECH**

**Bit-Driver® and Fiber Cluster® are registered trademarks of S.I. Tech, Inc.**  
© 2009 S.I. Tech, Inc. All Copy and Images

USA & INTERNATIONAL HEADQUARTERS  
1101 N. RADDANT ROAD ▪ BATAVIA ▪ IL 60510  
PO BOX 609 ▪ GENEVA ▪ IL 60134  
**NATIONWIDE TOLLFREE 1-866-SITECH-1 [(866) 748-3241]**  
**PHONE: (630) 761-3640 ▪ FAX: (630) 761-3644**  
WEB SITE: <http://www.sitech-bitdriver.com>  
E-MAIL: [sales@sitech-bitdriver.com](mailto:sales@sitech-bitdriver.com)



USA & INTERNATIONAL HEADQUARTERS  
1101 N. RADDANT ROAD ▪ BATAVIA ▪ IL 60510  
PO BOX 609 ▪ GENEVA ▪ IL 60134  
**NATIONWIDE TOLLFREE 1-866-SITECH-1 [(866) 748-3241]**  
**PHONE: (630) 761-3640 ▪ FAX: (630) 761-3644**  
WEB SITE: <http://www.sitech-bitdriver.com>  
E-MAIL: [sales@sitech-bitdriver.com](mailto:sales@sitech-bitdriver.com)